

COMPARISON BETWEEN PERFORMANCE ON A CONCEPT INVENTORY AND SOLVING OF MULTIFACETED PROBLEMS

Paul S. Steif¹

***Abstract** - Engineering science courses teach students to apply fundamental principles and methods to understand and quantify new, unfamiliar situations. Prompted by the finding that students often have widespread misconceptions regarding basic principles, researchers in physics education have developed concept inventories to assess conceptual understanding. In this paper, we put forth a methodology for exploring the relation between conceptual understanding, as judged by performance on a concept inventory, and efforts to solve to typical, multifaceted problems. Based on an early version of a concept inventory for Statics and a first attempt to employ this methodology, we find there indeed to be correlations between conceptual understanding and other general measures of performance on problem solving, and course success in general. However, we did not find a one-to-one correlation between an apparent understanding of specific concepts and the successful application of those concepts in problem solving.*

Index Terms - Concept Inventory, Misconception, Problem Solving, Statics).

INTRODUCTION

The goal of most engineering analysis courses is to empower students to apply established principles and methods to understand and quantify new, unfamiliar situations. The approach of most instructors is to cover what they believe to be the basic principles and methods and to offer various example problems that illustrate their application. That students often learn to solve a limited set of problems, *without* genuinely assimilating the underlying principles, has been clearly recognized in the domain of physics [1]. There, pre-Newtonian conceptions of physics have been shown to persist and require significant instructional interventions to address [2-5]. This has prompted the development of a now widely used test, the Force Concept Inventory [1], which is aimed specifically at assessing conceptual understanding. There are recent efforts to develop such inventories for a range of other subject areas in science and engineering [6].

Of course, instructors often wish to know whether devoting a greater fraction of time to underlying principles pays dividends in terms of problem-solving ability. Since the ability to solve problems involves application of concepts, surely one would hope that better understanding of concepts translate into improved problem solving ability.

Mazur[4], for one, has observed no diminishment in problem solving ability after having converted to a teaching style that accentuates conceptual understanding. However, problems in any domain are typically multifaceted, involving several principles simultaneously, appearing often in unfamiliar form. One appreciates, therefore, that problem solving relies on knowing when a concept is appropriate, implementing that concept with the symbols of the subject, carrying out an analysis and interpreting the result. So success in a concept test may not be not guarantor of success in problem solving generally. Nevertheless, one would hope that consistent failure to answer questions dealing with a particular concept correctly ought to be a predictor of failure to solve problems that require that principle.

In this paper we explain an approach to investigating the relation between conceptual understanding and problem solving ability in the subject of Statics. In short, a group of students who had completed a Statics course solved a pair of typical, multifaceted Statics problems. Shortly thereafter, the same group took a multiple-choice-answer concept inventory test. The performances at these two tasks were evaluated independently and blindly and were then compared. We then attempt to draw some preliminary conclusions regarding the inventory and its relevance to problem solving.

STATICS CONCEPT INVENTORY

Based on extensive and continuing efforts to recognize the primary set of concepts pertinent to Statics, and to categorize typical mistakes and misconceptions of students, we have begun developing a Statics Concept Inventory. (In Reference [7], there is an allusion to the development of a concept inventory for Statics, but it is not yet available for comparison.) Each question of our inventory focuses on a single concept in isolation, which is exemplified in a relatively simple context. There are five possible answers to each question; to the extent possible, the various wrong answers reflect common misconceptions. The inventory at the time of its use in this study had 20 questions, and focused on the most significant concepts in statics, including free body diagrams, the forces and moments acting at various connections, the association between moments, couples and forces, the conditions of equilibrium and limits due to friction. We show two example questions, pointing out the misconceptions or common pitfalls that are embedded in the possible answers.

¹ Paul S. Steif, Carnegie Mellon University, Department of Mechanical Engineering, Schenley Park, Pittsburgh, PA 15213 steif@cmu.edu

The first question (Figure 1) pertains to the construction of free body diagrams and includes the common circumstance of separating a system of bodies, with one or the other of the separated parts itself composed of more than one body. The problem statement is “Each of the bars shown has weight W . The bars are connected by ideal pin joints. Free body diagrams are to be constructed of AB and of BC and CD together. Which is the correct pair of free body diagrams?”

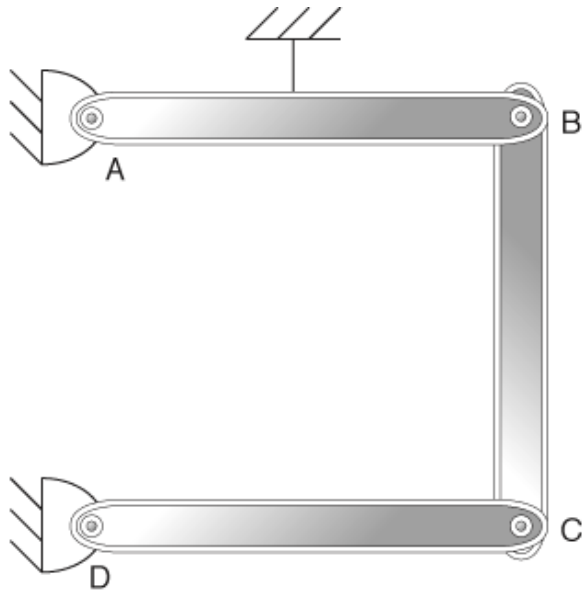

FIGURE 1
CONCEPT QUESTION ON FREE BODY DIAGRAMS

- One notices the following set of typical errors embedded in the answers (Figures 2a – 2e):
- (a) incorrectly presuming the value of a force (at B) based on a superficial (and incorrect) application of equilibrium
 - (b) correct answer
 - (c) incorrectly drawing a force of interaction between two bodies even though they are connected to one another
 - (d) leaving out the force of interaction between two connected bodies
 - (e) failing to make the forces of interaction between two separated bodies equal and opposite

The second example (Figure 3) addresses the forces/couples which must be present to keep a member in equilibrium when a known force is applied. The problem statement is: “The forces and couples in the load cases shown act at the points indicated in the directions shown. They could have any non-zero (positive) magnitudes. Which of these load cases could not possibly be in equilibrium, no matter what the non-zero positive magnitudes of the forces and couples?”

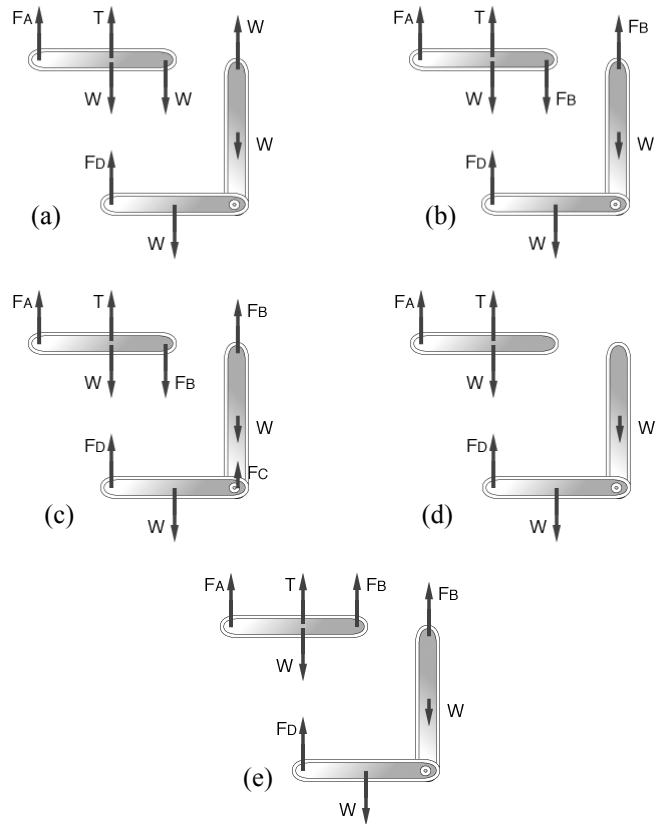

FIGURE 2
ANSWERS TO CONCEPT QUESTION ON FREE BODY DIAGRAMS

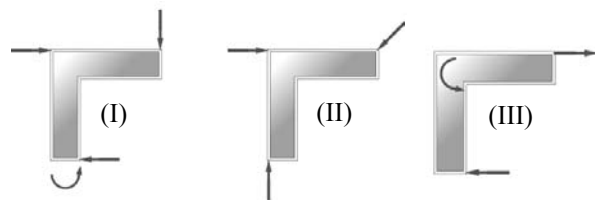

FIGURE 3
CONCEPT QUESTION ON CONDITIONS OF EQUILIBRIUM

The answers to choose from are:
(a) I; (b) II; (c) III; (d) I and II; (e) II and III

The three loadings tap into the tendency of students to ignore the balance of forces and/or the balance of moments.

MULTIFACETED PROBLEMS

As described above, typical problems confronted in statics are multifaceted, in that one must combine several aspects of Statics. The first multifaceted problem used in this study is shown in Figure 4. The students were asked to determine the reaction at the pin B. This problem involves separating bodies, properly representing the interactions at connections (a pin joint and a pin in a slot), constructing free

body diagrams, recognizing the presence of a two-force body, and imposing conditions of equilibrium.

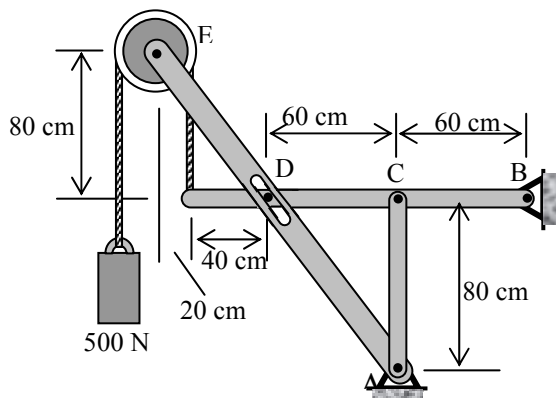

FIGURE 4
MULTIFACETED PROBLEM 1

The second multifaceted problem is shown in Figure 5. Values for the friction coefficients μ_A and μ_B , the angle θ and the masses of the blocks are given. Students were asked four questions. The first two questions dealt with the situation of force P_1 acting, but force P_2 being absent. Students were to determine the value for P_1 at which block C slides down the incline at steady speed and the value for P_1 at which block C slides up the incline at steady speed. Students were also to draw the free body diagrams of each of the blocks separately. The second pair of questions dealt with P_1 absent, and P_2 present. Two values were given for P_2 , and the student was to determine whether the system was in equilibrium, and if not, what was the motion. For both cases, the blocks were in equilibrium, with the frictional force not at the limit. However, if students took the friction force automatically to equal the friction coefficient times the normal force, a common misconception in dealing with friction, then the wrong conclusion will be reached.

PROCEDURE

This data for this study was drawn from the approximately 100 students enrolled in the Statics course in the mechanical engineering department at Carnegie Mellon in the fall 2002 semester. Most of these students continued on to take the mechanics of materials course in the spring semester. As part of the first homework assignment of the spring semester, students were given the two multifaceted problems shown above. These were clearly identified as a review of the material from the Statics course. It was desired to give such problems for homework, rather than in an examination, to afford them sufficient time to think the problems through. However, students were asked to solve these two problems as best they could without consulting one another. While students had been permitted to work with one another on homework in the previous course, students were accustomed to a homework-grading scheme

whereby they would get complete credit for any reasonable attempt to solve any given problem. Since students were assured of the usual credit-for-effort criterion, and were told that they would receive detailed feedback on their solutions, we assumed that students would work on their own. Indeed, there was no evidence of collaboration.

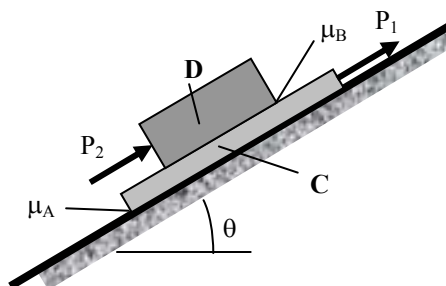

FIGURE 5
MULTIFACETED PROBLEM 2

Performance on multifaceted problems was quantified by establishing a list of various possible types of errors. For example, in the case of multifaceted problem 1, we tracked 19 distinct types of errors. There are several different types of errors related to drawing free body diagrams; for example, failures to: dismember bodies which need to be, include all interactions on a body isolated in a free body diagram, account for the equal and opposite nature of the forces between two contacting bodies. In treating the force between the pin and the inclined slot, errors included taking the force to be vertical (consistent with some other forces that are acting), or taking the force to be described by two unknown components in the plane. Such a fine-grained analysis enabled us to pinpoint which types of errors were more frequent relative to others. We could also lump together all errors pertaining to, say, free body diagrams. For each student, we would note if each one of these types of errors were made. We also tracked whether each student managed to solve the problem correctly in its entirety.

Several weeks later, the Statics Concept Inventory was administered during class. Students were not warned about this test and so had no opportunity to review or prepare for it. Students were also told that their score on this test did not influence their grade, but that they should make their best effort to answer questions correctly and not consult with one another. They were given 35 minutes to complete the 20-question multiple-choice test.

The results of this test were tabulated by recording each student's answer for each question. This enabled us to determine the frequency with which various wrong answers are chosen, thereby identifying the most common misconceptions. It could also allow us, in principle, to see patterns within any given student, for example whether a student makes a similar conceptual error consistently. A total of 81 students completed both the Statics Concept Inventory and handed in the multifaceted problems.

RESULTS

In this section we present a variety of results including correlations between overall performance on the inventory, performance on the multifaceted problems, and performance in Statics the previous semester. We then consider distinct concepts individually and we compare error rates on the inventory questions and the multifaceted problems. Finally, we identify misconceptions as judged by the specific incorrect answers given to inventory questions.

Comparisons between Performance on Multifaceted Problems, Statics Course Overall and Concept Inventory

To examine whether multifaceted problems chosen for comparison were representative of the previous semester's Statics course, we used two measures. Each student received a score of 0, 1 or 2 for the multifaceted problems, if they solved that number of problems *completely correctly* (Table I). A clear trend can be seen with grade level. From a one-way ANOVA, we found the differences between the A students and C students to be significant ($p < 0.02$).

Table I
MEAN SCORE ON MULTIFACETED PROBLEMS VERSUS GRADE IN PREVIOUS STATICS COURSE ($p < 0.02$)

Statics Grade	Multifaceted problem (2 max)
A (n = 25)	0.68
B (n = 30)	0.37
C (n = 21)	0.19

Alternatively, the examination average from the Statics course for students solving 0, 1, and 2 multifaceted problems *completely correctly* are shown in Table II. We found the differences in exam scores between those who solved no problems correctly and those who solved 1 or 2 problems correctly to be significant ($p < 0.001$).

Table II
MEAN EXAM SCORES IN PREVIOUS STATICS COURSE VERSUS NUMBER OF CORRECT MULTIFACETED PROBLEMS ($p < 0.001$)

Multifaceted Problems Correct	Statics Exam Total
0 (n = 48)	76%
1 (n = 24)	84%
2 (n = 4)	86%

For the entire class, the mean percentage of correct answers on the inventory was 74%. We also tracked the percentage correct of the problems attempted (some were left blank). On average, 82% of the questions attempted were answered correctly overall. To compare performance on the inventory with that on the multifaceted problems, we show the inventory scores of students solving 0, 1, and 2 multifaceted problems *completely correctly* in Table III. The differences between those who solved one or two multifaceted problems correctly were significant ($p < 0.005$

for total inventory score and $p < 0.04$ for score based on problems tried.

Table III
INVENTORY SCORES VERSUS NUMBER OF CORRECT MULTIFACETED PROBLEMS ($p < 0.005$ FOR TOTAL, $p < 0.04$ FOR TRIED)

Multifaceted Problems Correct	Inventory Correct of Total	Inventory Correct of Tried
0	0.70	0.79
1	0.81	0.86
2	0.76	0.89

Scores on the inventory also correlated with Statics course grades for the previous semester (Figure 6). The mean correct for A students was 0.82, for B students 0.75, and for C students 0.63. The difference between A and B students on the one hand and C students on the other was significant ($p < 0.0001$). The trend with grade is even more evident in Figure 7, where the inventory fraction correct of questions tried is plotted for the different grade levels.

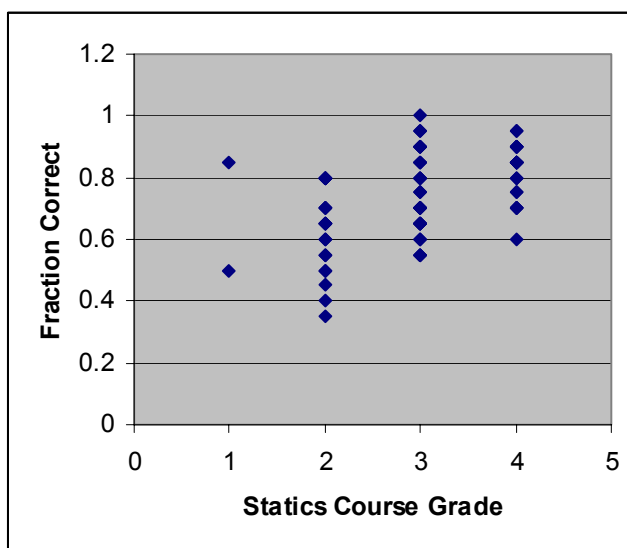

FIGURE 6
FRACTION OF INVENTORY QUESTIONS CORRECTLY ANSWERED AS A FUNCTION OF STATICS GRADE IN THE PREVIOUS SEMESTER

Although a good performance on the inventory is not a guarantor of a high grade, it can be seen that very few students who answered fewer than 60% of the inventory questions correctly received better than a grade of C. Furthermore, all students who received A's had scores on the inventory of 74% or better (of problems tried).

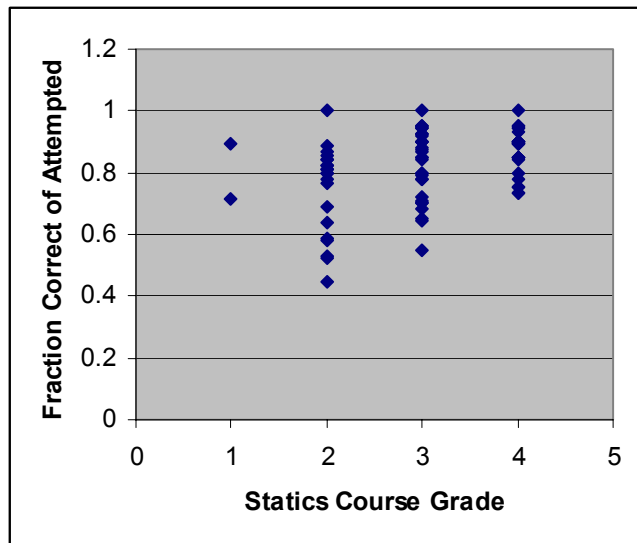

FIGURE 7

FRACTION OF INVENTORY QUESTIONS CORRECTLY ANSWERED OF THOSE ATTEMPTED AS A FUNCTION OF STATICS GRADE IN THE PREVIOUS SEMESTER

Comparison between Performances on Inventory and Multifaceted Problems for Specific Concepts

The percentage of students making errors in each of 6 categories of concepts were tabulated for inventory problems and displayed in Table IV. The number of inventory questions pertaining to each concept is shown in parentheses after the concept. There are two percentages under the inventory column. The first is the percentage of students who gave a wrong answer; the second is the percentage of students who did not give a right answer. The difference is due to some students not answering the question. The various types of errors from multifaceted problems were combined into groups that matched each set of concepts. These are also shown in Table IV, where the two percentages correspond to multifaceted problems 1 and 2, respectively. A percentage is left blank if the multifaceted problem contained no use of that concept.

Table IV

PERCENTAGES OF STUDENTS ERRING ON INVENTORY QUESTIONS AND ON MULTIFACETED PROBLEMS FOR VARIOUS CONCEPTS

Concept	Inventory	Multifaceted
FBD's (5)	30,37	46,51
Slot (1)	32,40	26,-
Two-force member (1)	0,1	9,-
Force at pin (1)	31,35	20,-
Equilibrium (4)	64,81	31,7
Friction (1)	36,44	-,52

Note that percentages listed under the multifaceted problems corresponded to students who clearly erred in some respect on that concept. It should be noted that this

percentage may be a lower bound. In some cases, a student might not have progressed sufficiently far in a problem to have encountered the need for a principle; such a student is not considered as having erred.

For nearly all concepts, there are substantial numbers of students who err in some way. However, we did not consistently find that students who made a particular error in the inventory to have a significantly different tendency to make the corresponding error in the multifaceted problem. Ultimately, one would hope that a concept inventory will offer predictive insight into concepts that a student is likely to misuse in problem solving. It should be noted, however, that in this version of the inventory there are generally insufficient numbers of questions covering many of the topics. It is also possible that questions in the inventory do not quite capture the concepts as they are confronted in actual problems. For example, even for the 50 students who made no errors on the 5 FBD inventory problems, 50% of them made errors on the multifaceted problems. There is likely to be a difference between recognizing something incorrect and creating something correct.

Misconceptions Evident from Performance on Inventory

Since the specific wrong answers on the inventory were tracked, it was possible to gain some insight into prevalent misconceptions.

Free body Diagrams: Generally, more than 90% of the students correctly answered four of the five questions related to free body diagram problems. For the fifth question, depicted in Figure 1, only 74% of the students answered correctly. The most common incorrect choice was (e) in Figure 2, which violates the condition of equal and opposite forces between two connected bodies.

Pin Joint: Approximately 10% of the students incorrectly indicated that there was a couple acting at a pin joint. A similar number indicated incorrectly that the direction of the force at the pin joint was dictated by the direction of another force acting on the member, the latter force direction being known because it is associated with a two-force member. This is an example of what seems to be rather common error. Rather than leaving the unknown force or couple at some connection as general as possible, consistent with what the connection *could* transmit, students (tacitly) apply equilibrium on an incomplete body and take the unknown connection force to be dictated by the need to equilibrate some nearby force.

Pin in a Slot More than 30% of the students incorrectly indicated that the direction of the force was not perpendicular to the slot. Judging by the frequency of wrong answers, we found the most common misconception is that the directions of other loads on the member with the pin trumped the need for the slotted member to exert only a

force perpendicular to the slot. This is another example of the tendency to jump to conclusions regarding interactions at connections, based on an improper application of equilibrium.

Equilibrium: Two of the four questions were answered correctly by nearly all students, and one question (the next to last one of the test) was left unanswered by many students. The other question (Figure 3 above) was answered by 85% of the students, and only 27% of these answered correctly. Students had to identify which of the three bodies are not in equilibrium. Two of these cannot be in equilibrium. Very few students made the error of identifying (III) as being out of equilibrium. But, many students recognized only one of the other two bodies as being out of equilibrium. These two bodies were out of equilibrium for distinct reasons, and were chosen by roughly similar numbers of students.

Friction: More than 23% of the students indicated incorrectly that the force on a frictional surface is the maximum frictional value μN rather than the lower value that is, for the given problem, necessary to maintain equilibrium.

SUMMARY

We have reported on an initial study of the correlations between performance on a multiple choice concept inventory in Statics and more traditional measures of problem solving ability. The concept inventory, which is being developed and has not been validated as a reliable instrument, featured 20 multiple choice questions addressing key concepts in Statics. These questions involve little or no calculation. A pair of traditional (multifaceted) Statics problems was chosen to serve as a direct comparison with performance on the inventory. Students in the Mechanics of Materials class (which immediately follows Statics) were asked to solve the multifaceted problems as part of homework, and took the Concept Inventory test a few weeks later in class.

In brief, we found there to be significant positive correlations between the overall performance in the previous Statics course (course grade and exam average) and success rate in solving the multifaceted problems. Hence, we took them as representative of Statics. Furthermore, we found that students who solved multifaceted problems correctly had statically significantly higher scores on the concept inventory. In addition, students who received A's and B's in the previous statics course scored significantly higher on the concept inventory than classmates who received C's. Analysis of the full set of inventory answers allowed us to identify common misconceptions, one important step in devising improved instructional strategies.

However, we were unable to find correlations between good performance on inventory questions addressing a specific concept and the ability to use that concept in the context of multifaceted problems. This certainly ought to be

a goal ultimately of a successful concept inventory; the concept inventory used here is as yet, admittedly, in its infancy. Besides, it must also be borne in mind that successful problem solving often relies on additional skills: recognizing the relevance of a concept, applying that concept correctly in context, and expressing the concept in symbols so as to lead to correct quantification. Detailed comparisons, such as those carried out here, between performance on a concept inventory and attempts to solve more typical multifaceted problems, may help to shed light on the dimensions of problem solving which go beyond understanding a concept in the context of an inventory.

ACKNOWLEDGMENT

The author appreciates the useful input from Andy Ruina regarding the questions on the Statics Concept Inventory and the assistance from Anne Fay in analyzing and interpreting the results. The author is grateful for the assistance of Peggy Martin in tabulating of the results from the concept inventory. Support by the Department of Mechanical Engineering at Carnegie Mellon University is gratefully acknowledged.

REFERENCES

- [1] Hestenes, D., Wells, M., Swackhammer, G, "Force Concept Inventory", *The Physics Teacher*, Vol. 30, 1992, pp. 141-151.
- [2] McDermott, L.C., "Physics by Inquiry", John Wiley & Sons, Inc., New York, 1996.
- [3] P. Laws, "Millikan Lecture 1996: Promoting Active Learning Based on Physics Education Research in Introductory Physics Courses," *Am. J. Phys.* Vol. 65, No. 1, 1997.
- [4] Mazur, E., *Peer Instruction*, Prentice Hall, New Jersey, 1997
- [5] R. R. Hake, "Interactive-engagemnt vs traditional methods: A six-thousand-student survey of mechanics test data for introductory physics courses," *Am. J. Phys.*, Vol. 66, 1998, pp. 64- 74.
- [6] D. L. Evans, C. Midkiff, R. Miller, J. Morgan, S. Krause, J. Martin, B. M. Notaros, D. Rancour, K. Wage, "Tools For Assessing Conceptual Understanding In The Engineering Sciences", 32nd ASEE/IEEE Frontiers in Education Conference, 2002.
- [7] Danielson, Scott and Sudhir Mehta, "Statics Concept Questions for Enhancing Learning," Proceedings, ASEE National Conference, St. Louis, MO, June 2000.