

ITEM NO.	PART NUMBER	DESCRIPTION	QTY.
1	Base	1/2" Plywood	1
2	Sidewall	Pine	1
3	Frontwall	Pine	1
4	Frontwall Top	Pine	1
5	Pin	Aluminum	1
6	Pivot Side Arm	Poplar	1
7	Pivot Front Arm	Poplar	1
8	9496T33	McMaster Carr	8
9	90198A173	McMaster Carr	6
10	9433K82	McMaster Carr - Spring	1

UNLESS OTHERWISE SPECIFIED:		DRAWN	NAME	DATE
DIMENSIONS ARE IN INCHES		CHECKED		
TOLERANCES:		ENG APPR.		
FRACTIONAL ±		MFG APPR.		
ANGULAR: MAACH ± BEND ±		Q.A.		
TWO PLACE DECIMAL ±		COMMENTS:		
THREE PLACE DECIMAL ±				
INTERPRET GEOMETRIC TOLERANCING PER:				
MATERIAL				
FINISH				
NEXT ASSY				

PROPRIETARY AND CONFIDENTIAL
 THE INFORMATION CONTAINED IN THIS DRAWING IS THE SOLE PROPERTY OF [INSERT COMPANY NAME HERE]. ANY REPRODUCTION IN PART OR AS A WHOLE WITHOUT THE WRITTEN PERMISSION OF [INSERT COMPANY NAME HERE] IS PROHIBITED.

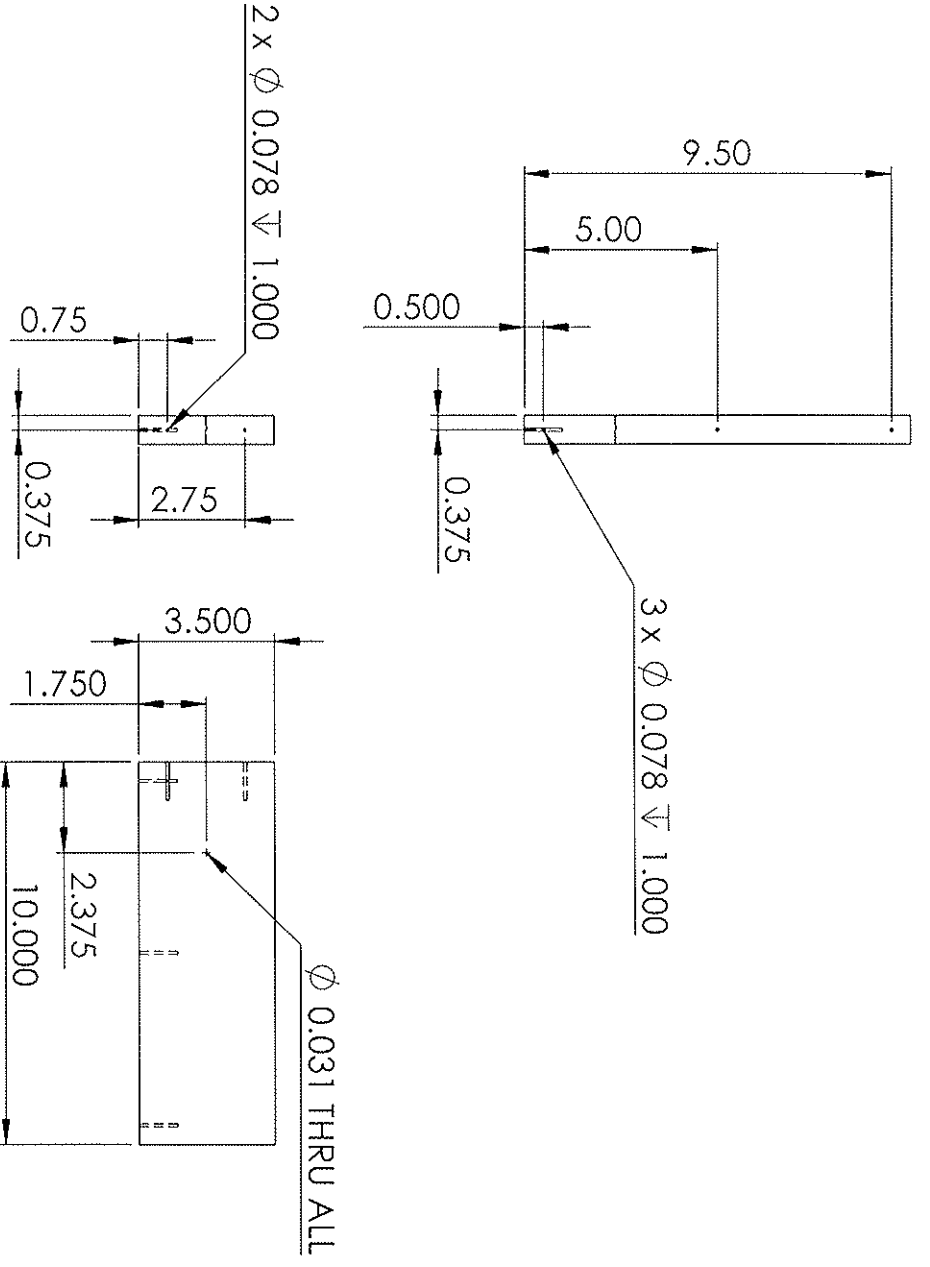

SolidWorks Student License
Academic Use Only

REPRODUCTION IN PART OR AS A WHOLE
 WITHOUT THE WRITTEN PERMISSION OF
 KISSERT COMPANY NAME HERE IS
 PROHIBITED.

5

4

3

2

1

UNLESS OTHERWISE SPECIFIED:		DRAWN	NAME	DATE
DIMENSIONS ARE IN INCHES		CHECKED		
TOLERANCES:		ENG APPR.		
FRACTIONAL ±		MFG APPR.		
ANGULAR: MACH ±		Q.A.		
BEND ±		COMMENTS:		
TWO PLACE DECIMAL ±				
THREE PLACE DECIMAL ±				
INTERPRET GEOMETRIC TOLERANCING PER:				
MATERIAL				
FINISH				
DO NOT SCALE DRAWING				
APPLICATION	USED ON			
NEXT ASSY				
TITLE:				
SIZE	DWG. NO.	SCALE: 1:5	WEIGHT:	SHEET 1 OF 1
A	Sidewall			
	REV			

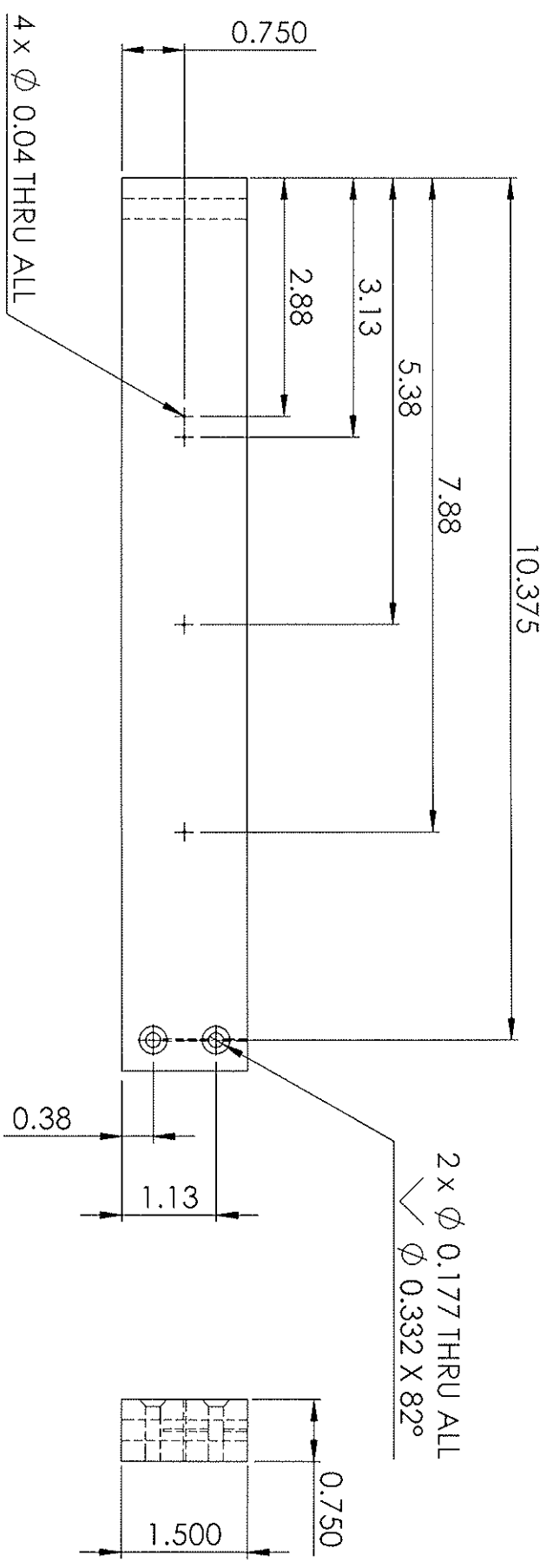
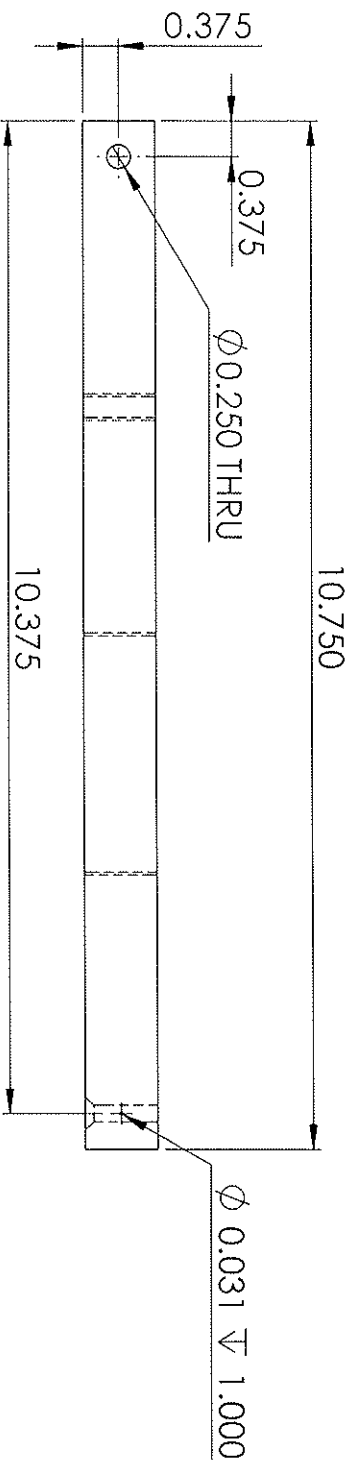

UNLESS OTHERWISE SPECIFIED:		DRAWN	NAME	DATE
DIMENSIONS ARE IN INCHES		CHECKED		
TOLERANCES:		ENG APPR.		
FRACTIONAL ±		MFG APPR.		
ANGULAR MATCH ±		Q.A.		
BEND ±		COMMENTS:		
TWO PLACE DECIMAL ±				
THREE PLACE DECIMAL ±				
INTERPRET GEOMETRIC TOLERANCING PER:				
MATERIAL				
FINISH				
USED ON				
NEXT ASSY				

SolidWorks Student License
Academic Use Only
 REPRODUCTION IN PART OR AS A WHOLE
 WITHOUT THE WRITTEN PERMISSION OF
 DYNESIGHT COMPANY NAME HEREIN IS
 PROHIBITED.

SIZE	DWG. NO.	REV
A	Pivot Side Arm	
SCALE: 1:5	WEIGHT:	SHEET 1 OF 1

5 4 3 2 1

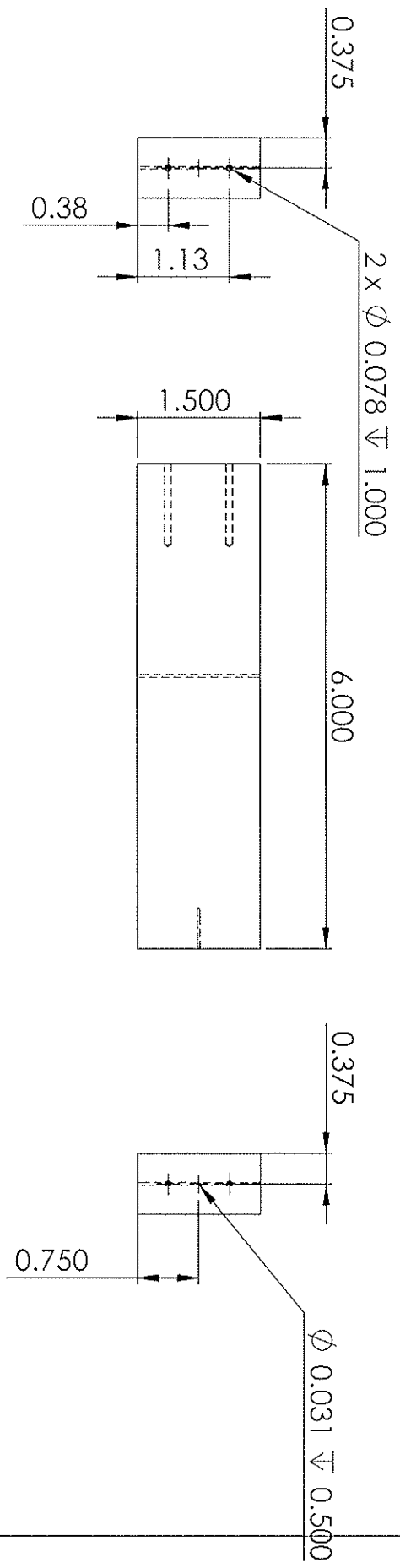
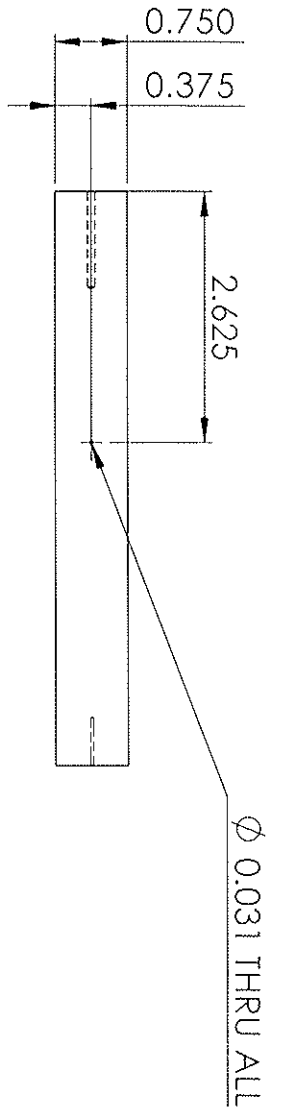

SolidWorks Student License

Academic Use Only

REPRODUCTION IN PART OR AS A WHOLE WITHOUT THE WRITTEN PERMISSION OF SISEET COMPANY NAME HERE IS PROHIBITED.

5 4 3 2 1

UNLESS OTHERWISE SPECIFIED:		NAME	DATE
DIMENSIONS ARE IN INCHES			
TOLERANCES:			
FRACTIONAL ±			
ANGULAR: MACH ±			
BEND ±			
TWO PLACE DECIMAL ±			
THREE PLACE DECIMAL ±			
INTERPRET GEOMETRIC TOLERANCING PER:			
MATERIAL			
FINISH			
DO NOT SCALE DRAWING			
DRAWN			
CHECKED			
ENG APPR.			
MFG APPR.			
Q.A.			
COMMENTS:			
TITLE:			
SIZE	DWG. NO.		REV
A	Pivot Front Arm		
SCALE: 1:2	WEIGHT:		SHEET 1 OF 1

REPRODUCTION IN PART OR AS A WHOLE WITHOUT THE WRITTEN PERMISSION OF SISEET COMPANY NAME HERE IS PROHIBITED.

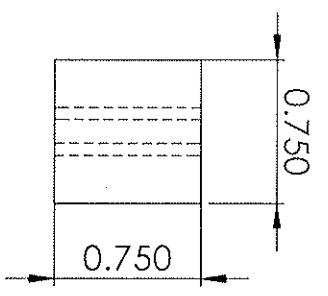
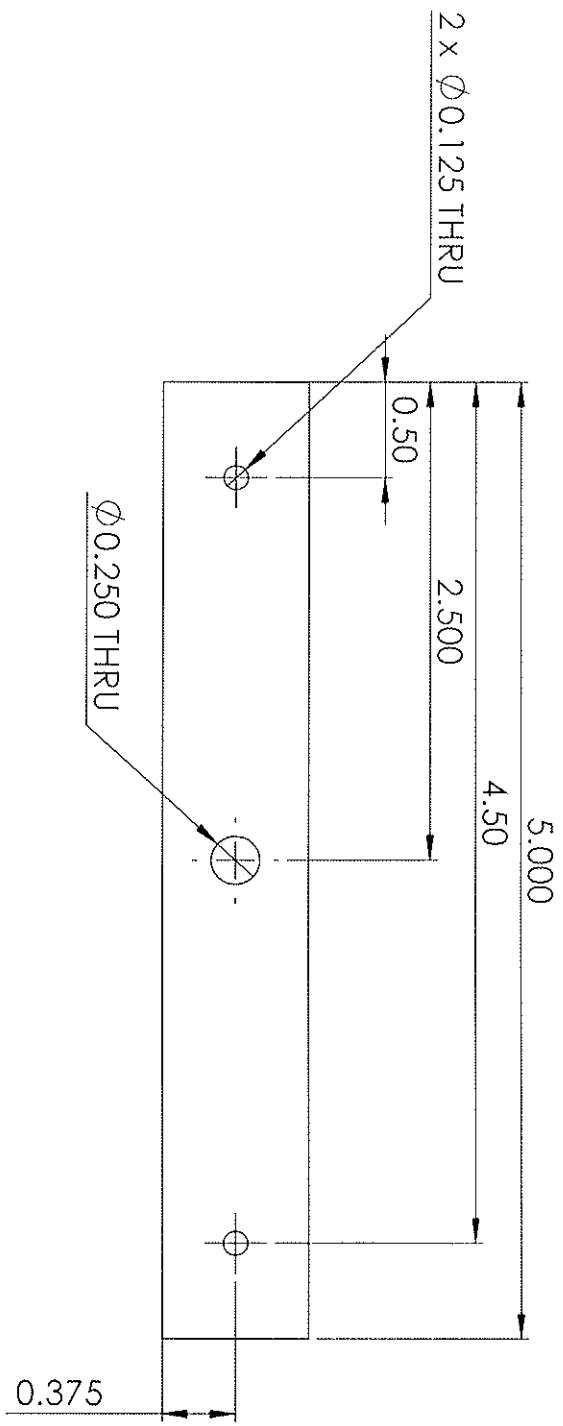

SolidWorks Student License

Academic Use Only

REPRODUCTION IN PART OR AS A WHOLE WITHOUT THE WRITTEN PERMISSION OF SIEMENS COMPANY NAME HEREIN IS PROHIBITED.

UNLESS OTHERWISE SPECIFIED:	
DIMENSIONS ARE IN INCHES	
TOLERANCES:	
FRACTIONAL ±	
ANGULAR: MACH ±	BEND ±
TWO PLACE DECIMAL ±	THREE PLACE DECIMAL ±
INTERPRET GEOMETRIC TOLERANCING PER:	
MATERIAL	
FINISH	
DRAWN	NAME
CHECKED	DATE
ENG APPR.	
MFG APPR.	
Q.A.	
COMMENTS:	

SIZE	DWG. NO.	REV
A	Frontwall Top	

SCALE: 1:1	WEIGHT:	SHEET 1 OF 1
------------	---------	--------------

5 4 3 2 1

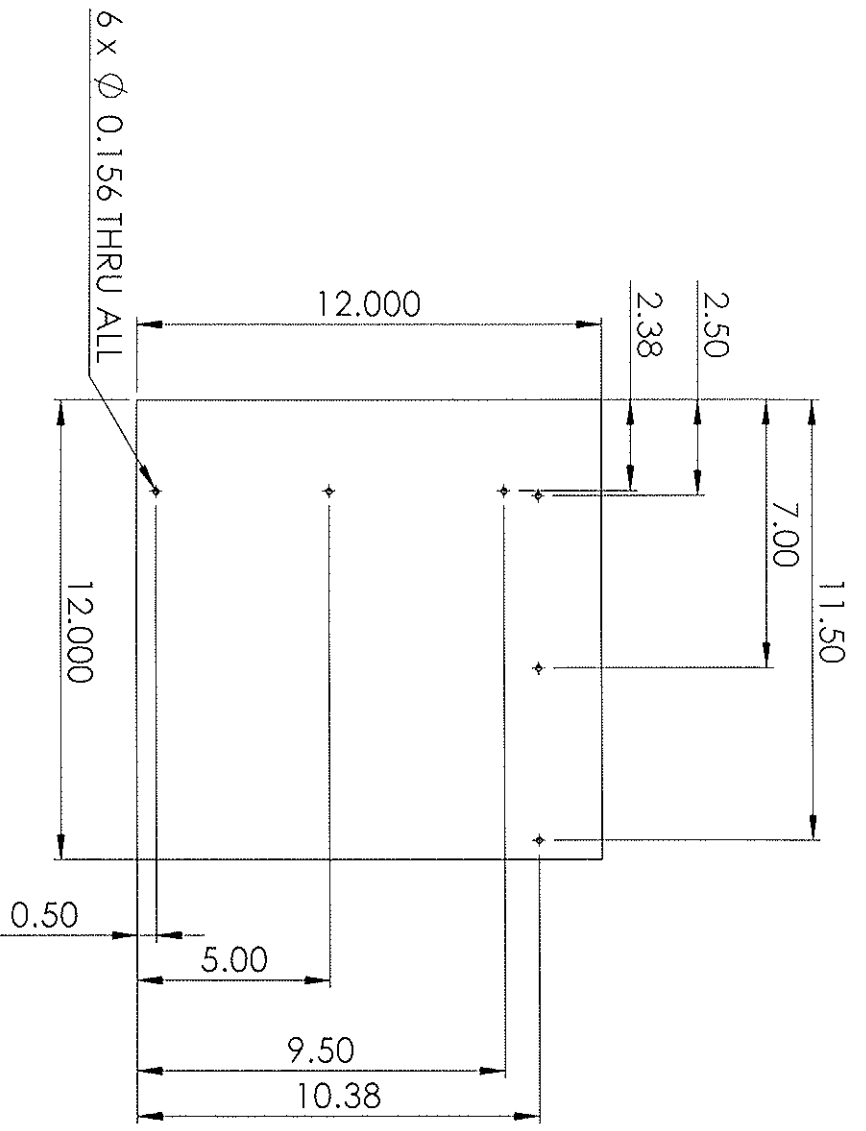

SolidWorks Student License
Academic Use Only

REPRODUCTION IN PART OR AS A WHOLE
 WITHOUT THE WRITTEN PERMISSION OF
 <INSERT COMPANY NAME HERE> IS
 PROHIBITED.

5 4 3 2 1

		UNLESS OTHERWISE SPECIFIED:		DRAWN		NAME		DATE	
		DIMENSIONS ARE IN INCHES		CHECKED					
		TOLERANCES:		ENG. APPR.					
		FRACTIONAL ±		MFG. APPR.					
		ANGULAR: MACH ±		Q.A.					
		BEND ±		COMMENTS:					
		TWO PLACE DECIMAL ±							
		THREE PLACE DECIMAL ±							
		INTERPRET GEOMETRIC							
		TOLERANCING PER:							
		MATERIAL							
NEXT ASSY		USED ON		FINISH		DO NOT SCALE DRAWING		TITLE:	
APPLICATION								SIZE DWG. NO.	
								A Base	
								SCALE: 1:5 WEIGHT: SHEET 1 OF 1	
								REV	

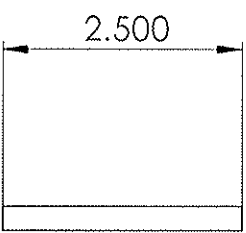

SolidWorks Student License Academic Use Only

REPRODUCTION IN PART OR AS A WHOLE
WITHOUT THE WRITTEN PERMISSION OF
SINUSERT COMPANY NAME HERE- IS
PROHIBITED.

5 4 3 2 1

UNLESS OTHERWISE SPECIFIED:		DRAWN		NAME	DATE	TITLE:	SIZE	DWG. NO.	Pin	REV												
DIMENSIONS ARE IN INCHES		CHECKED									COMMENTS:	A	1:1	SHEET 1 OF 1								
TOLERANCES:		ENG APPR.													Q.A.	SCALE: 1:1	WEIGHT:	SHEET 1 OF 1				
FRACTIONAL ±		MFG APPR.																	INTERPRET GEOMETRIC TOLERANCING PER:	1	1	1
ANGULAR: MACH ±																						
BEND ±						DO NOT SCALE DRAWING																
TWO PLACE DECIMAL ±						MATERIAL																
THREE PLACE DECIMAL ±						MATERIAL																

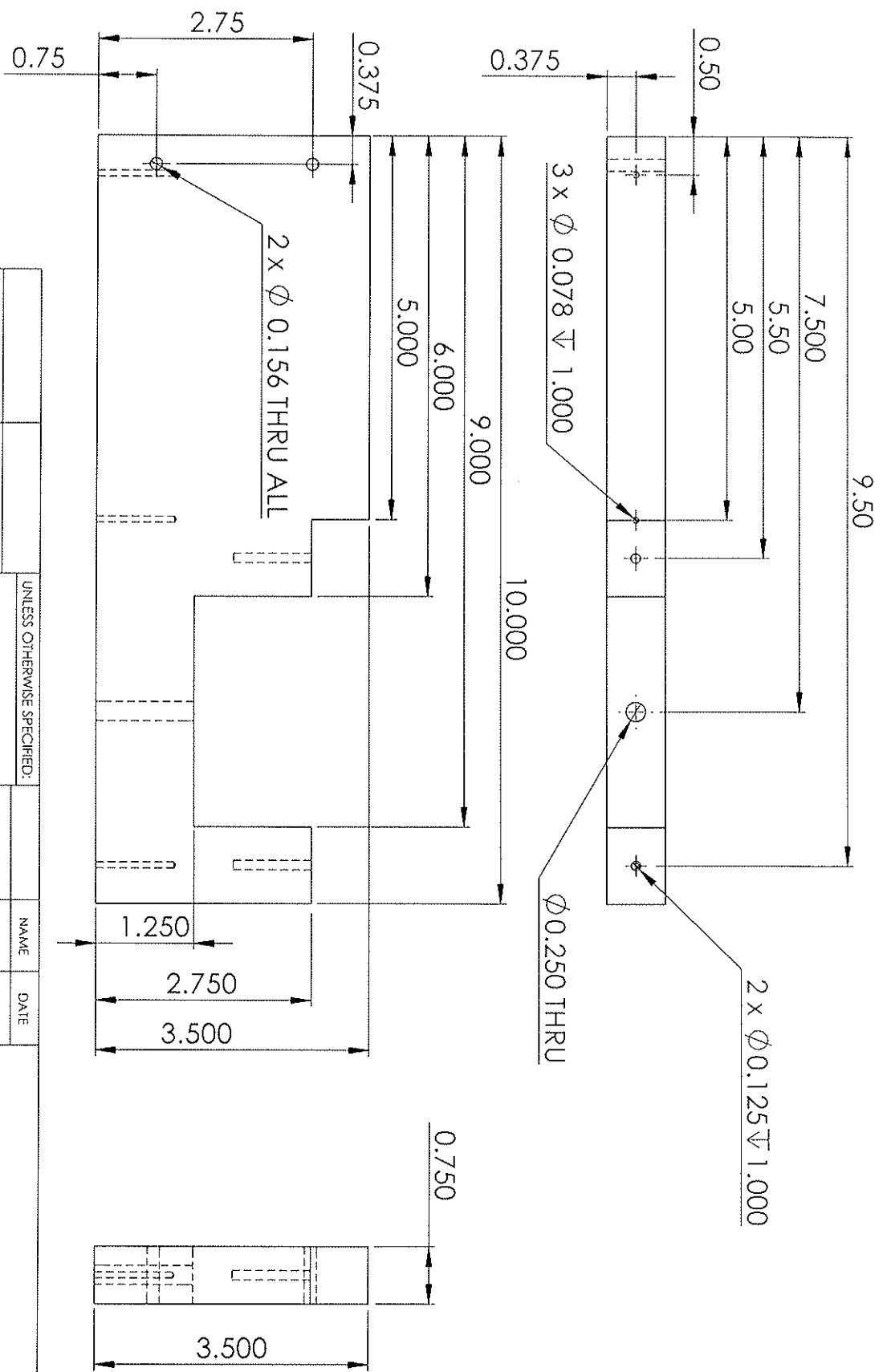

SolidWorks Student License
Academic Use Only

REPRODUCTION IN PART OR AS A WHOLE
 WITHOUT THE WRITTEN PERMISSION OF
 <INSERT COMPANY NAME HERE> IS
 PROHIBITED.

5 4 3 2 1

UNLESS OTHERWISE SPECIFIED: DIMENSIONS ARE IN INCHES TOLERANCES: FRACTIONAL \pm ANGULAR: MACH \pm BEND \pm TWO PLACE DECIMAL \pm THREE PLACE DECIMAL \pm INTERPRET GEOMETRIC TOLERANCING PER: MATERIAL		DRAWN	NAME	DATE	TITLE:
FINISH		CHECKED			SIZE DWG. NO.
DO NOT SCALE DRAWING		ENG APPR.			A Frontwall
APPLICATION		MFG APPR.			SCALE: 1:2 WEIGHT: SHEET 1 OF 1
NEXT ASSY		Q.A.			REV
USED ON		COMMENTS:			