

Strategies for optimizing heterologous protein expression in *Escherichia coli*

Gerhard Hannig and Savvas C. Makrides

The many advantages of *Escherichia coli* have ensured that it remains a valuable host for the efficient, cost-effective and high-level production of heterologous proteins. Here, we describe the current status of this prokaryotic expression system and focus on strategies designed to maximize the yields of recombinant proteins. Major challenges facing this expression system are also outlined.

Escherichia coli is the most frequently used prokaryotic expression system for the high-level production of heterologous proteins. However, despite its many advantages, the efficient expression of different genes in *E. coli* is not a routine matter, as the unique structural features of different genes and their transcribed mRNAs preclude the adoption of a generally applicable expression method. Comprehensive reviews on gene expression in *E. coli* have been published recently^{1,2}. Here, we summarize the salient features of a robust prokaryotic expression system and discuss a variety of strategies to optimize protein production in *E. coli*.

Essential components of expression vectors

A well-designed prokaryotic expression vector (Fig. 1) contains a set of optimally configured genetic elements that affect both transcriptional and translational aspects of protein production. In addition, the inclusion of an antibiotic-resistance gene facilitates phenotypic selection of the vector, and the origin of replication (Ori) determines the vector copy number.

Promoters

The many different types of promoters (Table 1) can affect the level of gene expression in *E. coli*. The suitability of promoters (see Glossary) for high-level gene expression is governed by several criteria. First, the promoter must be strong, capable of protein production in excess of 10–30% of the total cellular protein. Second, the promoter should exhibit a minimal level of basal transcription; a highly repressible promoter is particularly important for cases in which the protein of interest is toxic or detrimental to the growth of the host cell. Third, promoters should be capable of induction in a

simple and cost-effective manner. Thermal and chemical induction are widely used techniques in large-scale protein production. Isopropyl- β -D-thiogalactopyranoside (IPTG) is an effective inducer of the powerful hybrid *tac* and *trc* promoters. However, for the large-scale production of human therapeutic proteins, IPTG is not ideal because of its toxicity and cost. The recent introduction of a temperature-sensitive mutant *lacI* gene that encodes a thermosensitive *lac* repressor provides a convenient method to induce *lac*-based promoters^{3–5}. A disadvantage of thermally inducible gene expression is the induction of the heat-shock response and the concomitant upregulation of proteases. This problem is minimized by the use of host strains with a deficient *rpoH* (*htpR*) locus.

Transcription terminators

Transcription through a promoter may inhibit its function, and this interference can be prevented by placing a transcription terminator upstream of the promoter, after the previous coding sequence; similarly, a transcription terminator placed upstream of the promoter that drives expression of the gene of interest will minimize background transcription. It is also known that continued transcription from strong promoters into the replication region can destabilize plasmids owing to overproduction of the ROP protein, which is involved in the control of plasmid copy number. In addition, transcription terminators enhance mRNA stability and can substantially increase the level of protein production¹.

Elements affecting translational initiation

Unique structural features at the 5' end of the mRNA transcript are the major determinants of the efficiency of mRNA translational initiation. To date, no universally effective translation-initiation consensus sequence has been identified, but several

G. Hannig (hannig@ppi.com) and S. C. Makrides (makrides@ppi.com) are at PRAECIS Pharmaceuticals, 1 Hampshire Street, Cambridge, MA 02139, USA.

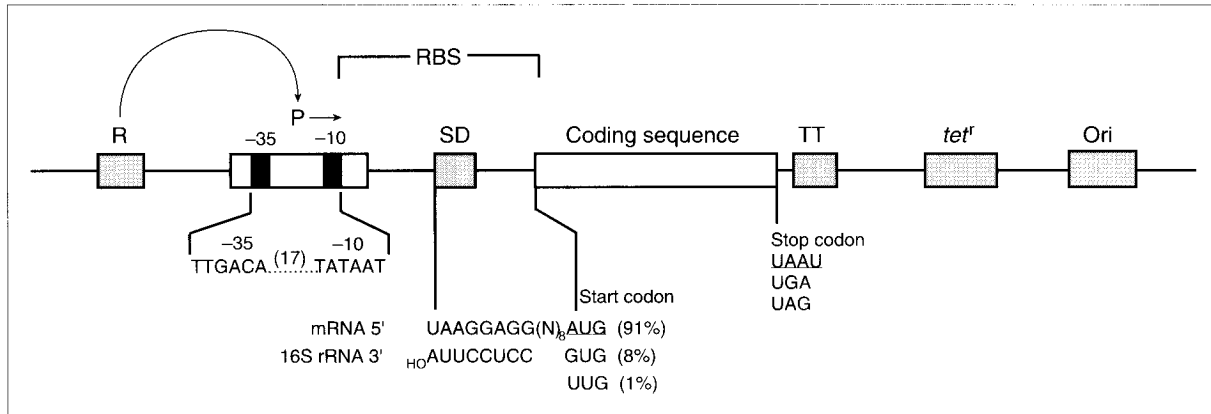

Figure 1

Schematic presentation of the salient features of a prokaryotic expression vector. Shown as an example is the *tac* promoter (P) consisting of the -35 and -10 sequences, which are separated by a 17-base spacer. The arrow indicates the direction of transcription. The ribosome binding site (RBS) consists of the Shine-Dalgarno (SD) sequence followed by an AT-rich translational spacer that has an optimal length of approximately eight bases. The SD sequence interacts with the 3' end of the 16S ribosomal RNA during translational initiation, as shown. The three start codons are shown, along with the frequency of their usage in *E. coli*. Of the three stop codons, UAA followed by U is the most efficient translational-termination sequence in *E. coli*. The repressor is encoded by a regulatory gene (R) that modulates the activity of the promoter, and which may be present on the vector itself or integrated into the host chromosome; the transcription terminator (TT) serves to stabilize the mRNA and the vector; an antibiotic-resistance gene (e.g. for tetracycline) facilitates phenotypic selection of the vector; the origin of replication (Ori) determines the vector copy number. The various features are not drawn to scale. From Ref. 1, with permission from the publisher.

strategies have been developed to reduce the potential for secondary-structure formation at the 5' end of the transcript. These include the enrichment of the ribosome binding site (RBS) sequence with adenine and thymidine residues, the mutation of specific residues and the use of translationally coupled systems¹.

Translational enhancers

Sequence elements from *E. coli* and bacteriophages have been shown to enhance heterologous gene expression in *E. coli* markedly. Such 'translational enhancers' include: a sequence from the T7-phage gene-10 leader; U-rich regions in the 5' untranslated region (UTR) of certain mRNAs, such as the *E. coli atpE* gene; and the 'downstream box' located immediately downstream of the start codon in T7 genes¹. Their precise mechanism of action, however, is poorly understood, and these sequences do not function as universal translational enhancers in *E. coli*⁴.

Translational terminators

The presence of a stop codon is an indispensable signal for termination of mRNA translation, and *E. coli* expression vectors frequently contain all three stop codons to prevent ribosome 'skipping'. *E. coli* displays a strong bias towards the UAA codon, but translational-termination efficiency is further improved in the context of the tetranucleotide UAAU⁶.

mRNA-stabilizers

Rapid degradation of mRNA may compromise protein production. Specific sequences in the 5' UTR of certain mRNAs, such as the *E. coli ompA* transcript, have been shown to prolong the half-life of several labile heterologous mRNAs, as has the addition of a protective hairpin structure at the 5' terminus¹. Furthermore, mRNA stability can be enhanced by several 3'-UTR-derived sequences that form stem-loop structures at the 3' terminus. None of the stabilizing

Glossary

Promoter	An <i>Escherichia coli</i> promoter consists of a hexanucleotide sequence located approximately 35 bp upstream of the transcription initiation base (-35 region) separated by a short spacer from another hexanucleotide sequence (-10 region).
Ribosome binding site	The ribosome binding site in an optimized-expression vector extends from the -10 sequence of the promoter to the beginning of the coding sequence.
Shine-Dalgarno site	The consensus Shine-Dalgarno sequence (AGGA) is contained within the ribosome binding site ; it interacts with the 3' terminus of the ribosomal RNA during translation initiation.
Chaperones	Chaperones are multifunctional proteins that catalyse the correct folding of other proteins by preventing side reactions such as aggregation; they are not themselves components of the final functional proteins. Different members of the chaperone family assist in folding in a concerted manner. Some, but not all, molecular chaperones are heat-shock or stress proteins.
PEST sequences	In eukaryotes, these are regions rich in proline (P), glutamic acid (E), serine (S) and threonine (T) that result in the intracellular degradation of proteins containing them.

Table 1. Promoters used for the high-level expression of genes in *Escherichia coli*

Promoter (source)	Regulation	Induction
<i>lac</i> (<i>Escherichia coli</i>)	<i>lacI</i> , <i>lacI</i> ^Q <i>lacI</i> ts ^b , <i>lacI</i> Qts ^b <i>lacI</i> ts ^c	IPTG ^a Thermal Thermal Tryptophan starvation, indole acrylic acid
<i>trp</i> (<i>E. coli</i>) <i>lpp</i> (<i>E. coli</i>) <i>phoA</i> (<i>E. coli</i>)	<i>phoB</i> (positive) <i>phoR</i> (negative)	IPTG, lactose ^d Phosphate starvation
<i>recA</i> (<i>E. coli</i>) <i>araBAD</i> (<i>E. coli</i>) <i>proU</i> (<i>E. coli</i>) <i>cst-1</i> (<i>E. coli</i>) <i>tetA</i> (<i>E. coli</i>) <i>cadA</i> (<i>E. coli</i>) <i>nar</i> (<i>E. coli</i>) <i>tac</i> (hybrid) (<i>E. coli</i>)	<i>lexA</i> <i>AraC</i>	Nalidixic acid L-Arabinose Osmolarity Glucose starvation Tetracycline
<i>trc</i> (hybrid) (<i>E. coli</i>)	<i>cadR</i> <i>fnr</i>	pH Anaerobic conditions, nitrate ions
<i>lpp-lac</i> (hybrid) (<i>E. coli</i>) <i>P</i> _{syn} (synthetic) (<i>E. coli</i>) <i>P</i> _{LtetO-1} (<i>E. coli</i>) <i>P</i> _{lac-ara1} (<i>E. coli</i>) Starvation promoters (<i>E. coli</i>) <i>P</i> _L (bacteriophage λ) <i>P</i> _{L-9G-50} (mutant) (λ) <i>cspA</i> (<i>E. coli</i>) <i>P</i> _R , <i>P</i> _L (tandem) (λ) T7 (T7) T7- <i>lac</i> operator (T7) λ <i>P</i> _L , <i>P</i> _{T7} (tandem) (λ , T7) T3- <i>lac</i> operator (T3) T5- <i>lac</i> operator (T5) T4 gene 32 (T4) <i>nprM-lac</i> operator (<i>Bacillus</i>) VHb (<i>Vitreoscilla</i>) Protein A (<i>Staphylococcus aureus</i>)	<i>lacI</i> , <i>lacI</i> ^Q <i>lacI</i> ^e <i>lacI</i> , <i>lacI</i> ^Q <i>lacI</i> ts, <i>lacI</i> Qts <i>lacI</i> <i>lacI</i> , <i>lacI</i> ^Q <i>lacI</i> ts857 <i>lacI</i> ts857 Cascaded system ^f <i>lacI</i> ^Q <i>lacI</i> ts857, <i>lacI</i> ^Q <i>lacI</i> ^Q <i>lacI</i> ^Q , <i>lacI</i>	Thermal IPTG Thermal IPTG Thermal IPTG Anhydrotetracycline IPTG, arabinose Thermal Reduced temperature (<20°C) Reduced temperature (<20°C) Thermal IPTG IPTG Thermal, IPTG IPTG IPTG T4 infection IPTG Oxygen, cAMP-CAP ^g
^a Isopropyl- β -D-thiogalactopyranoside. ^b <i>lacI</i> gene with single mutation, Gly187Ser. ^c <i>lacI</i> gene with three mutations, Ala241Thr, Gly265Asp, Ser300Asn. ^d The constitutive <i>lpp</i> promoter (<i>P</i> _{lpp}) was converted into an inducible promoter by insertion of the <i>lacUV5</i> promoter-operator region downstream of the <i>P</i> _{lpp} . Thus, expression occurs only in the presence of a <i>lac</i> inducer. ^e Wild-type <i>lacI</i> gene. ^f Expression of T7 RNA polymerase is controlled by the <i>lacUV5</i> promoter, which is regulated by the <i>lac</i> repressor. Production of T7 RNA polymerase causes transcription of the recombinant gene which is under the control of the ϕ 10 promoter. ^g Cyclic-AMP-catabolite-activator protein. Modified from Ref. 1, with permission from the publisher.		

sequences identified to date functions as a 'universal stabilizer' in heterologous mRNAs, but their integration into otherwise highly unstable transcripts may be effective on an ad hoc basis.

Codon usage

Codon usage in *E. coli* displays a bias; that is, it shows a nonrandom usage of synonymous codons. Heterologous genes that contain a substantial number of codons that are rarely used in *E. coli* may thus be expressed inefficiently. Moreover, it appears that the occurrence of rare codons is correlated with a low level of their

cognate tRNA species. This has led to the development of two alternative strategies to minimize the effects of preferential codon usage in *E. coli*. The first relies on genetically altering rare codons in the target gene, without modifying the encoded protein product, in order to reflect the specific codon bias of the host. In the second, the intracellular tRNA pool is expanded by coexpressing genes that encode rare tRNAs such as the *argU* (*dnaY*) gene that encodes the minor tRNA^{Arg(AGG/AGA)} (Refs 4,7). However, results from several studies employing this approach have been inconsistent, and unambiguous 'rules' have not been

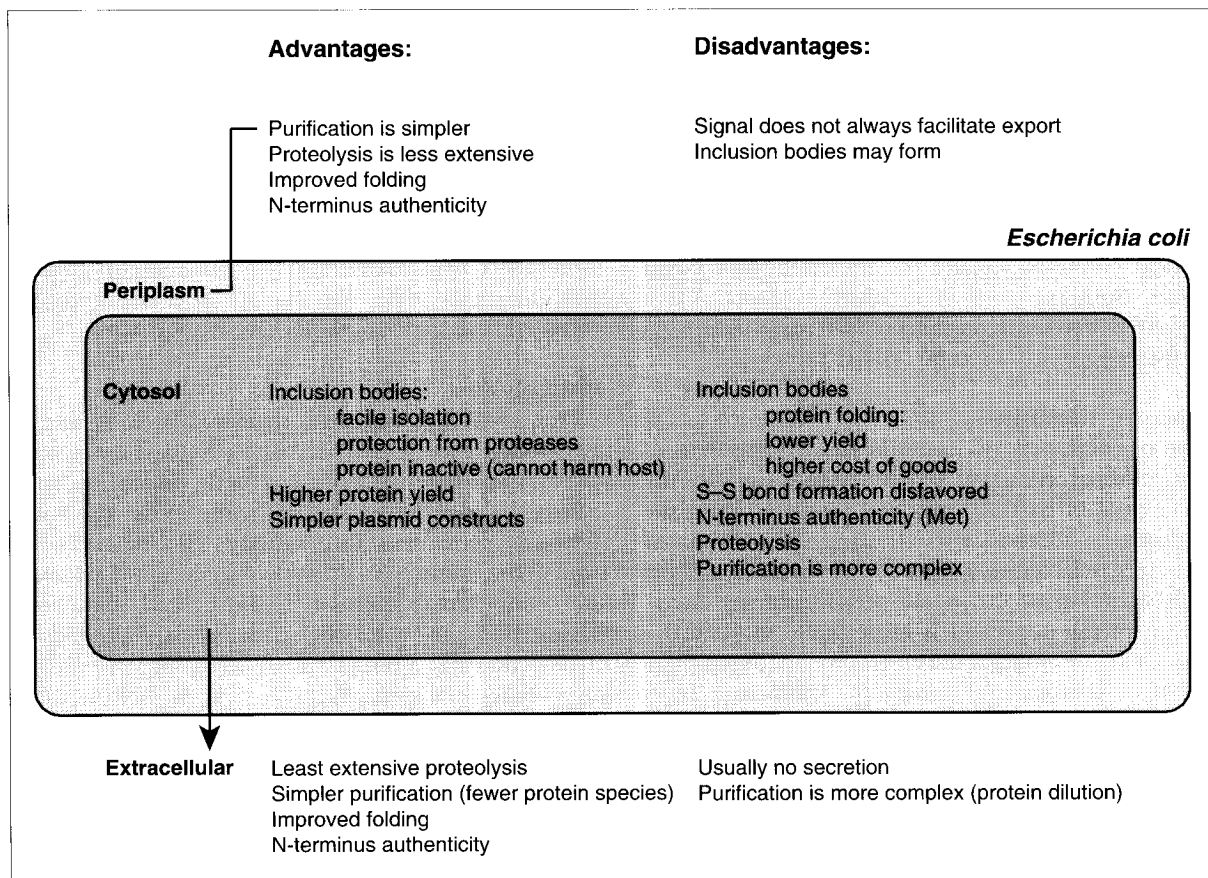

Figure 2

Summary of the advantages and disadvantages of each compartment of *E. coli* for protein production.

established to correlate codon usage and translation of a transcript¹. It appears, however, that the presence of rare codons near the 5' end of a transcript affects translational efficiency. In addition, the GC content of the 5' coding region of certain genes appears to influence expression, as demonstrated for the human thymidylate synthase (TS) gene⁸. In this case, conversion of the purine bases in the third, fourth and fifth codons of the TS cDNA to thymine, without altering the encoded protein, facilitated the expression of the TS gene to 25–30% of the total protein in *E. coli*.

Choice of cellular compartment for protein expression

The decision to target the expressed protein to a specific cellular compartment, that is, to the cytoplasm, periplasm or the culture medium, rests on balancing the advantages and disadvantages of each compartment (Fig. 2).

Cytoplasmic expression

The formation of insoluble aggregated folding intermediates, termed inclusion bodies, is a frequent consequence of high-level protein production in the cytoplasm. For many proteins, major physicochemical parameters correlated with this process are charge average and turn-forming-residue fraction, cysteine and proline fractions, hydrophilicity and total number of

residues⁹. A model based on those parameters has successfully been applied to predict the insolubility of the human T-cell receptor V β 5.3 (Ref. 4). Production of recombinant proteins as inclusion bodies has several advantages (Fig. 2). However, the recovery of biologically active protein from inclusion bodies may be too expensive for large-scale production¹⁰. Several expression strategies have been developed to aid the formation of the native three-dimensional protein structure, including coexpressing molecular chaperones, using thioredoxin-deficient host strains to maintain a favorable redox potential, reducing the rate of protein synthesis, growing bacterial cultures at lower temperatures and using highly soluble polypeptides as fusion partners¹.

The coexpression of molecular chaperones may be a promising route to enhance protein solubility and folding^{11–13}. However, although the coexpression of chaperones increased the production of several monomeric and multimeric proteins, the success of this strategy appears to be protein specific^{10,12,14}. Several factors contribute to the inability of overexpressed proteins to fold into their authentic configuration, even in the presence of molecular chaperones, including the lack of disulfide bonds and/or the absence of post-translational modifications; the redox state of the cytoplasm militates against the formation of disulfide bonds. In *E. coli*, two pathways contribute to the reduction of

disulfide bonds – the thioredoxin system, which is composed of thioredoxin reductase and thioredoxin, and the glutaredoxin system, which consists of glutathione reductase, glutathione and three glutaredoxins¹⁵. Strategies to generate a less-reducing cytoplasmic environment that facilitates disulfide bond formation include the use of *E. coli* strains deficient in thioredoxin reductase (*trxB*), which contributes to the sulfhydryl-reducing potential. Finally, the purification of target proteins from the pool of cytoplasmic proteins is a relatively difficult task, as this compartment comprises the vast majority of the total cellular protein.

Periplasmic expression

The periplasm affords ease and cost-effectiveness of purification of the target protein from a significantly smaller pool of bacterial proteins compared with the cytoplasm. In addition, the oxidizing environment of the periplasm facilitates proper protein folding, and the *in vivo* cleaving of the signal peptide during translocation to the periplasm is more likely to yield the authentic N-terminus of the target protein. Signal peptides of prokaryotic and eukaryotic origin have been utilized successfully for this purpose¹, but the presence of a signal peptide does not always ensure efficient protein translocation through the inner membrane^{4,16} because other structural features are involved in membrane transport¹. Several strategies for improved translocation of proteins to the periplasm have been reported, including the overproduction of the signal peptidase I, a reduction in protein-expression levels in order to prevent the overloading of the translocation machinery and the coproduction of several proteins that participate in membrane-transport processes¹.

Protein folding in the periplasm may be facilitated by overexpressing two classes of enzymes – protein disulfide isomerases (PDI, designated Dsb in *E. coli*), which are exclusively periplasmic and catalyse the oxidation of disulfide bonds, and peptidyl-prolyl-*cis-trans* isomerases (PPI), which catalyse the isomerization of X-Pro bonds. Co-overexpression at low temperature of DsbA and the heat-shock factor σ^{32} increased the yield of correctly folded T-cell-receptor (TCR) fragment¹⁷. Similarly, the coexpression of eukaryotic PDI enhanced the yield of correctly folded pectate lyase C (Ref. 18) and bovine pancreatic trypsin inhibitor¹⁹.

Secretion into the extracellular medium

Protein secretion into the extracellular medium might be a desirable strategy. As *E. coli* ordinarily secretes very few proteins into the extracellular medium, this ‘compartment’ has the lowest level of proteolytic activity, and the purification of the presumably soluble, structurally authentic protein would be greatly facilitated owing to the few contaminating bacterial proteins. Unfortunately, this strategy is currently not a viable one for the large-scale production of heterologous proteins in *E. coli*. Proteins that are targeted for secretion into the extracellular medium have to cross two different membrane barriers, the cytoplasmic and outer membranes, and passage through

these is a highly specific process. To date, our knowledge of the molecular mechanisms that regulate membrane-translocation steps, in particular through the outer membrane, remains incomplete^{20,21}. In general, methods for protein secretion into the culture medium fall into two categories: the utilization of existing pathways for secreted proteins²² and the use of signal sequences, fusion partners and permeabilizing agents that effect protein secretion as a result of selective and limited permeability of the outer membrane¹. In general, protein yields with all these methods have been modest.

Proteolysis

Proteolysis is a selective, regulated process that is involved in a variety of metabolic activities, such as the removal of abnormal and incorrectly folded proteins. Systematic studies have defined some of the structural determinants of protein instability. The ‘N-end rule’ proteolytic pathway is functional in *E. coli*²³, whereas the ubiquitin-dependent²⁴ and PEST-sequence-dependent²⁵ (see Glossary) pathways are limited to eukaryotic cells. Strategies for minimizing proteolysis of recombinant proteins in *E. coli*, as well as their limitations, have been reviewed in detail^{1,26}, including targeting proteins to the periplasm or the culture medium, using protease-deficient host strains, growing the host cells at low temperature, constructing N- and/or C-terminal fusion proteins, fusing multiple tandem copies of the target gene, coexpressing molecular chaperones or the T4 *pin* gene, replacing specific amino acid residues in order to eliminate protease cleavage sites, modifying the hydrophobicity of the target protein, and optimizing the fermentation conditions.

Fusion proteins

The development of sophisticated protein-fusion systems has facilitated high-level production and purification of recombinant proteins in *E. coli*. Fusion partners offer several advantages, such as prevention of inclusion-body formation, improved folding characteristics, limited proteolysis and generic protein-purification schemes^{1,27} (Table 2). Widely used fusion proteins include staphylococcal protein A, streptococcal protein G, *Schistosoma japonicum* glutathione-S-transferase, maltose-binding protein, thioredoxin, DsbA and ubiquitin. The detection and purification of proteins may also be facilitated by the use of affinity tags, such as the FLAG, His₆ and c-Myc peptides (Table 2).

Fermentation conditions

Protein production in *E. coli* can be increased significantly through the use of high-cell-density culture systems, which can achieve cell concentrations in excess of 100 g dry weight l⁻¹. Several studies of fermentation systems have been published²⁸⁻³¹, and these show that nutrient composition and fermentation variables such as temperature and pH can affect mRNA translation, proteolytic activity, secretion and production levels. Specific manipulations of the culture medium have been shown to enhance protein release into the medium without causing significant cell lysis. However,

Table 2. Fusion partners and their ligands^a

Fusion partner	Ligand/matrix
FLAG peptide (DYKDDDDK)	Anti-FLAG monoclonal antibodies
His ₆	Ni ²⁺ -nitrilotriacetic acid
Glutathione-S-transferase	Glutathione-sepharose
Staphylococcal protein A	IgG-sepharose
Streptococcal protein G	Albumin
Calmodulin	Organic and peptide ligands, DEAE-sephadex
Calmodulin-binding peptides	Calmodulin
Thioredoxin	ThioBond™ resin
β-Galactosidase	TPEG ^b -sepharose
Ubiquitin	
Chloramphenicol acetyltransferase	Chloramphenicol-sepharose
S-peptide (Ribonuclease A, residues 1–20)	S-protein (ribonuclease A, residues 21–124)
Myosin heavy chain	
DsbA	
Biotin subunit (<i>in vivo</i> biotinylation)	
Avidin	Biotin
Streptavidin	Biotin
Strep-tag	Streptavidin
c-Myc	Anti-Myc antibody
Dihydrofolate reductase	Methotrexate-agarose
CKS ^c	
Polyarginine	S-Sepharose
Polycysteine	Thiopropyl-sepharose
Polyphenylalanine	Phenyl-superose
<i>lac</i> Repressor	<i>lac</i> Operator
T4 gp55	
Growth hormone, N-terminus	
Maltose-binding protein	Amylose resin
Galactose-binding protein	Galactose-sepharose
Cyclomaltodextrin glucanotransferase	α-Cyclodextrin-agarose
Cellulose-binding domain	Cellulose
Haemolysin A (<i>E. coli</i>)	
λ cII Protein	
TrpE or TrpLE	
Protein-kinase site(s)	
(Ala-Trp-Trp-Pro) _n	
HA1 epitope ^d	
BTag	Anti-BTag antibodies
VP7 protein region of Bluetongue virus	
Green fluorescent protein	

^aIn addition to their utility in purification and detection, specific fusion peptides may confer advantages on the target protein during expression, such as increased solubility or yield, protection from proteolysis, improved folding, and secretion. The engineering of specific protease sites in fusion proteins facilitates the cleavage and removal of the fusion partner(s).

^bTPEG, *p*-amino-phenyl-β-D-thiogalactoside.

^cCTP: CMP-3-deoxy-D-manno-octulosonate cytidyltransferase.

^dInfluenza-virus haemagglutinin.

Modified from Ref. 1 with permission of the publisher.

high-cell-density culture systems suffer from several drawbacks, including limited availability of dissolved oxygen at high cell density, carbon dioxide levels that can decrease growth rates and stimulate acetate formation, reduction in mixing efficiency in the fermenter, and heat generation. The techniques that are used to minimize such problems have been examined in detail²⁸.

Future directions

Several challenges remain to be addressed in order to further enhance the value of *E. coli* as an expression system.

(1) The achievement of enhanced yields of correctly folded proteins by manipulating the molecular-chaperone machinery of the cell. This might be achieved by the coexpression of multiple chaperone-encoding genes or by methods that activate a large battery of different chaperone molecules in the cell.

(2) The problems of the expression of eukaryotic membrane proteins or multisubunit protein complexes in *E. coli* have so far not been addressed.

(3) The realization of a 'true' and robust secretion mechanism for the efficient release of protein into the culture medium. This will require an improved understanding of the various secretion pathways in *E. coli*.

(4) The endowment of the prokaryotic cell with the ability to perform some of the post-translational modifications found in eukaryotic proteins, such as glycosylation, phosphorylation, acetylation or amidation. This might be achieved by engineering the appropriate eukaryotic enzymes on plasmids or into the *E. coli* chromosome. It is unlikely, however, that we will be able to achieve extensive glycosylation functions in *E. coli*, considering the complexity of the eukaryotic glycosylation pathways. On the other hand, other eukaryotic post-translational functions, such as phosphorylation, have been achieved in *E. coli* using a variety of plasmid systems³².

In conclusion, there has been significant progress in many technical aspects of gene expression in *E. coli*. The many advantages of this prokaryote have ensured that it remains a valuable tool for the production of recombinant proteins in both basic research and commercial applications.

Acknowledgment

We thank the reviewers for their thoughtful comments on the manuscript.

References

- 1 Makrides, S. C. (1996) *Microbiol. Rev.* 60, 512–538
- 2 Georgiou, G. (1996) in *Protein Engineering: Principles and Practice* (Cleland, J. L. and Craik, C. S., eds), pp. 101–127, Wiley-Liss
- 3 Adari, H., Andrews, B., Ford, P. J., Hannig, G., Brosius, J. and Makrides, S. C. (1995) *DNA Cell Biol.* 14, 945–950
- 4 Andrews, B. *et al.* (1996) *Gene* 182, 101–109
- 5 Hasan, N. and Szybalski, W. (1995) *Gene* 163, 35–40
- 6 Poole, E. S., Brown, C. M. and Tate, W. P. (1995) *EMBO J.* 14, 151–158
- 7 Brinkmann, U., Mattes, R. E. and Buckel, P. (1989) *Gene* 85, 109–114
- 8 Pedersen-Lane, J., Maley, G. F., Chu, E. and Maley, F. (1997) *Protein Express. Purif.* 10, 256–262
- 9 Wilkinson, D. L. and Harrison, R. G. (1991) *Biotechnology* 9, 443–448
- 10 Georgiou, G. and Valax, P. (1996) *Curr. Opin. Biotechnol.* 7, 190–197
- 11 Martin, J. and Hartl, F. U. (1997) *Curr. Opin. Struct. Biol.* 7, 41–52
- 12 Wall, J. G. and Plückthun, A. (1995) *Curr. Opin. Biotechnol.* 6, 507–516
- 13 Yasukawa, T., Kaneishii, C., Maekawa, T., Fujimoto, J., Yamamoto, T. and Ishii, S. (1995) *J. Biol. Chem.* 270, 25328–25331
- 14 Cole, P. A. (1996) *Structure* 4, 239–242
- 15 Prinz, W. A., Åslund, F., Holmgren, A. and Beckwith, J. (1997) *J. Biol. Chem.* 272, 15661–15667
- 16 Novotny, J. *et al.* (1991) *Proc. Natl. Acad. Sci. U. S. A.* 88, 8646–8650
- 17 Wülfing, C. and Plückthun, A. (1994) *J. Mol. Biol.* 242, 655–669
- 18 Humphreys, D. P., Weir, N., Mountain, A. and Lund, P. A. (1995) *J. Biol. Chem.* 270, 28210–28215
- 19 Ostermeier, M., De Sutter, K. and Georgiou, G. (1996) *J. Biol. Chem.* 271, 10616–10622
- 20 Sandkvist, M. and Bagdasarian, M. (1996) *Curr. Opin. Biotechnol.* 7, 505–511
- 21 Pugsley, A. P., Francetic, O., Possot, O. M., Sauvonnnet, N. and Hardie, K. R. (1997) *Gene* 192, 13–19
- 22 Stader, J. A. and Silhavy, T. J. (1990) *Methods Enzymol.* 185, 166–187
- 23 Tobias, J. W., Shrader, T. E., Rocap, G. and Varshavsky, A. (1991) *Science* 254, 1374–1377
- 24 Baker, R. T. (1996) *Curr. Opin. Biotechnol.* 7, 541–546
- 25 Rogers, S., Wells, R. and Rechsteiner, M. (1986) *Science* 234, 364–368
- 26 Murby, M., Uhlén, M. and Ståhl, S. (1996) *Protein Express. Purif.* 7, 129–136
- 27 LaVallie, E. R. and McCoy, J. M. (1995) *Curr. Opin. Biotechnol.* 6, 501–506
- 28 Lee, S. Y. (1996) *Trends Biotechnol.* 14, 98–105
- 29 Yamane, T. and Shimizu, S. (1984) *Adv. Biochem. Eng.* 30, 147–194
- 30 Yee, L. and Blanch, H. W. (1992) *Biotechnology* 10, 1550–1556
- 31 Kramer, W., Elmecker, G., Weik, R., Mattanovich, D. and Bayer, K. (1996) *Ann. New York Acad. Sci.* 782, 323–333
- 32 Mukerji, P., Thurmond, J. M. and Hansson, L. (1996) PCT Patent Application WO 96/27017

Do you wish to contribute an article to **TIBTECH?**

If so, send a brief (half to one page) outline of the proposed content of your article, stating which section of the journal you wish it to be considered for.
You may also suggest topics and issues that you would like to see covered by the journal.

Please contact:

Dr Meran Owen (Editor), *Trends in Biotechnology*,
Elsevier Trends Journals,
68 Hills Road,
Cambridge, UK CB2 1LA.

(Fax: +44 1223 464430)