

THE HEINZ ARCHITECTURAL CENTER  
AT CARNEGIE MUSEUM OF ART PRESENTS

# Frank Lloyd Wright Renewing the Legacy

OCTOBER 1, 2005–JANUARY 15, 2006

*Frank Lloyd Wright: Renewing the Legacy* brings together two iconic buildings by Frank Lloyd Wright, the Darwin D. Martin House (1905) in Buffalo, New York, and the H.C. Price Company Office Tower and Apartments (1956) in Bartlesville, Oklahoma. The exhibition presents Wright's original designs alongside new associated projects by New York-based Toshiko Mori and London-based Zaha Hadid, women recognized as visionary leaders in contemporary architecture.

Mori is to construct an elegant, glass-walled visitors center on the Martin House property. Concurrently, Hadid is designing a dramatic arts center, adjacent to the Price Tower, that responds to the site's contours. These designs and Wright's original projects are presented through drawings, models, furniture, decorative arts, film, and photographs.

## Opening Lecture and Reception

Friday, September 30, 6:00 p.m., Carnegie Lecture Hall, free  
Toshiko Mori, chair, Department of Architecture, Graduate School of Design, Harvard University, discusses her design for a visitors center at the Darwin D. Martin House in Buffalo, New York. Reception follows; exhibition remains open until 9:00 p.m.

## Tours

Drop-in, 30-min. guided exhibition tours Friday–Sunday, 1:00 p.m., free with museum admission, meet at the admissions desk. Group tours for adults or students can be scheduled through the group visits office, 412.622.3289.

## Symposium: Architecture and Urban Revitalization: Frank Lloyd Wright in Buffalo and Bartlesville

Saturday, October 1, 10:00 a.m.–noon, museum theater  
free with museum admission

Explore Frank Lloyd Wright's original designs for the Martin House and the Price Tower, the second life these buildings are gaining through extensive restoration, and the new complementary projects intended for these sites. Speakers include Jack Quinan, historian and author of *Frank Lloyd Wright's Martin House: Architecture as Portrait*; Richard Townsend, executive director, Price Tower Arts Center; and Wendy Evans Joseph, architect for the The Inn at Price Tower.

## Subscription Series: Frank Lloyd Wright and Beyond

Tuesday, October 11–November 8, 6:00–7:30 p.m., museum theater

Single sessions: \$16 members; \$20 nonmembers

Discount, all 5: \$72 members; \$90 nonmembers

October 11: *Breaking the Box: Wright and the Prairie Style* > Kai Gutschow, assistant professor, School of Architecture, Carnegie Mellon

October 18: *Abstraction and Ornament: Wright's Engagement with Modern Architecture* > Kai Gutschow

October 25: *Peter Berndtson and Cornelia Brierly: Precedent and Principle* > Charles Rosenblum, architectural historian and critic

November 1: *The Taliesin Fellowship Legacy* > Gerald Morosco, architect and Taliesin Fellow

November 8: *Wright's Influence at Home and Abroad* > Raymund Ryan, curator of architecture, Carnegie Museum of Art, and organizer of the exhibition *Frank Lloyd Wright: Renewing the Legacy*

## Tour of Fallingwater and Kentuck Knob

Saturday, October 29, 7:45 a.m.–5:00 p.m.

departs from the museum's Forbes Avenue fountain entrance  
\$68 members; \$80 nonmembers

Visit Wright's Western Pennsylvania masterworks. Fee includes admission to the sites, guided tours, deluxe motor coach transportation, and box lunch.

The programs of the Heinz Architectural Center are made possible by the generosity of the Drue Heinz Trust. Support for *Frank Lloyd Wright: Renewing the Legacy* has been provided by Mellon Financial Corporation. General support for museum programs is provided by the Pennsylvania Council on the Arts, The Heinz Endowments, and Allegheny Regional Assets District.

Image credits: top left Zaha Hadid, site view, proposed museum for the Price Tower Arts Center, 2003, courtesy of Zaha Hadid Architects, London; bottom left Frank Lloyd Wright, The Martin House complex seen from Summit Avenue, c. 1918, collection of the Buffalo and Erie County Historical Society, New York; right flap, top to bottom Joe Price, Price Tower historical photograph, 1952–1956, gift of Etsuko and Joe Price, courtesy of the Price Tower Arts Center, Bartlesville, Oklahoma; Frank Lloyd Wright, c. 1924, courtesy of the Frank Lloyd Wright Archives, Taliesin West, Scottsdale, Arizona; Toshiko Mori, model of proposed Darwin D. Martin House Visitors Center, 2003, Reid Freeman, photographer, courtesy of Toshiko Mori Architecture, New York; back Zaha Hadid, interior view, proposed museum for the Price Tower Arts Center, 2003, courtesy of Zaha Hadid Architects, London.

## Subscription Series: "FRANK LLOYD WRIGHT & BEYOND

Dr. Kai Gutschow, CMU (gutschow@cmu.edu)

Oct. 11, 2005, CmoA Theater, 6:00pm

### "Breaking the Box: Wright and the Prairie Style"

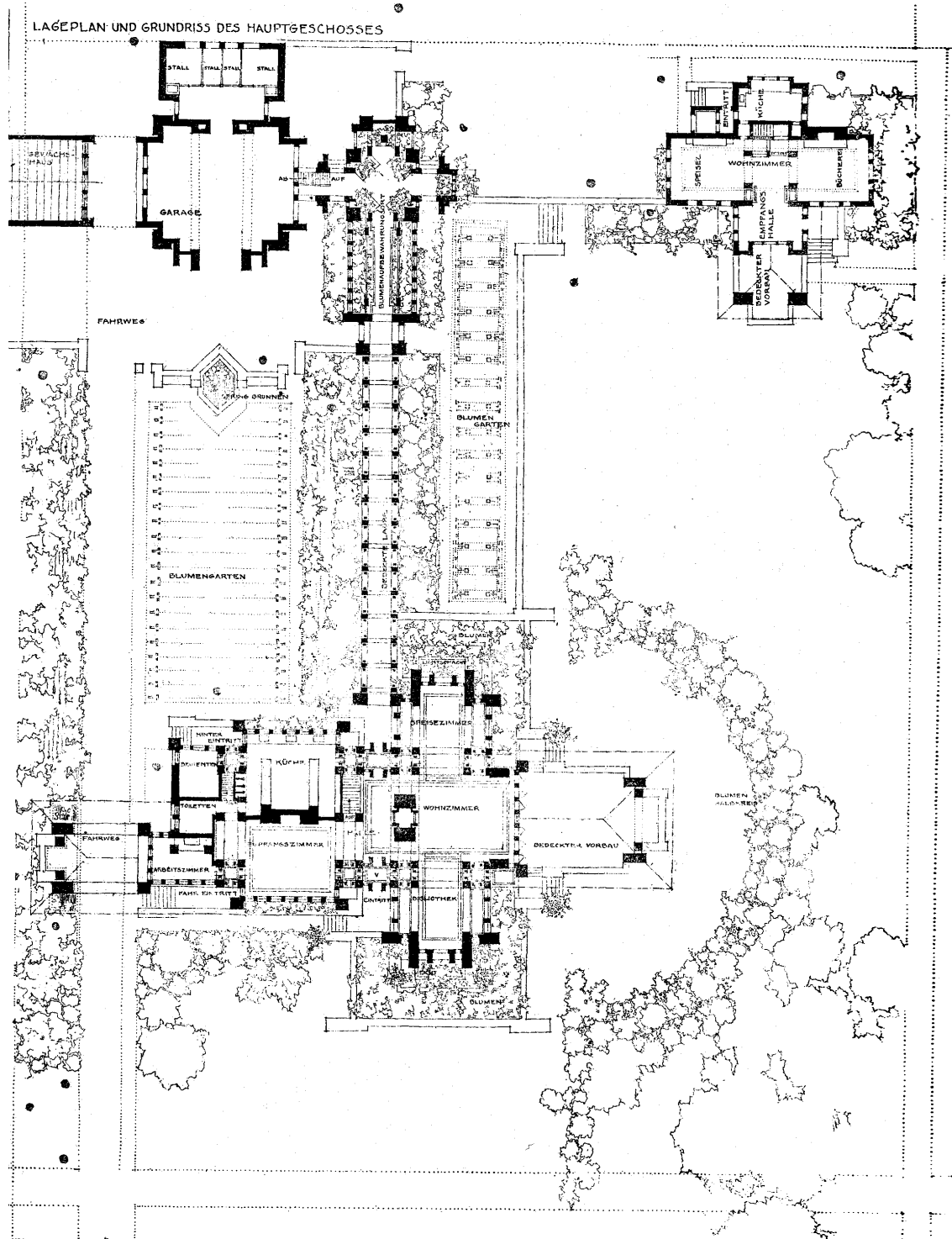

D.D. Martin Hou

### Bibliography

J. Quinan, FLW's Martin House. Arch. as Portraiture  
F.L. Wright, An American Architecture  
R. McCarter, ed. FLW. A Primer on Arch'l Principles  
D. Hoffmann, Understanding FLW's Architecture  
H.A. Brooks, ed. Writings on Wright

P. Laseau & J. Tice, FLW: Between Principle and Form  
G. Hildebrand, The Wright Space. Pattern & Meaning in FLW's Houses  
N. Levine, "FLW's Diagonal Planning" in In Search of Architecture

# PRECEDENTS

# PLAN ANALYSIS

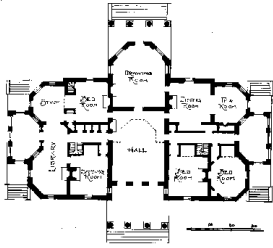

Monticello, Jefferson, ca. 1780



Fig. 70

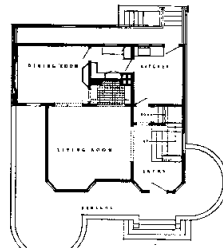

FLW Own House, 1889

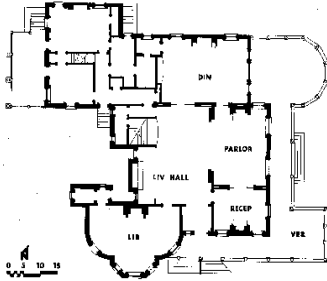

Bell Hse, Newport, M.M.W, 1881

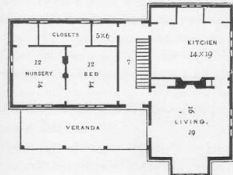

Downin, "Amer. Cottage," 1850

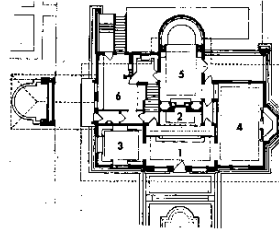

FLW, Winslow House, 1893

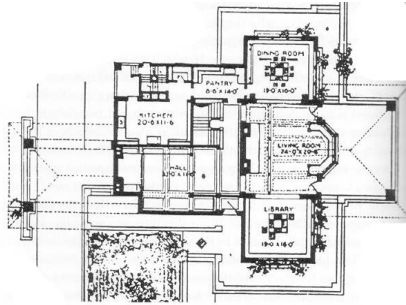
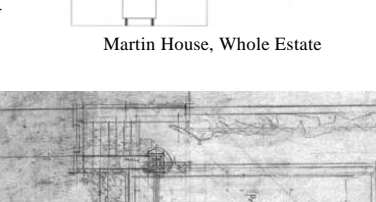
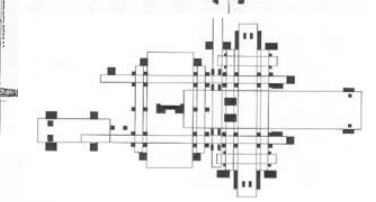
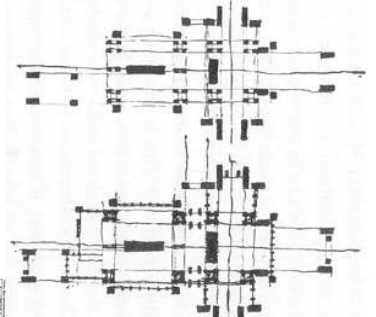
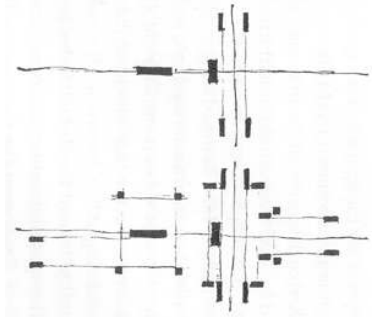

FLW, "Home for a Prairie Town," 1900

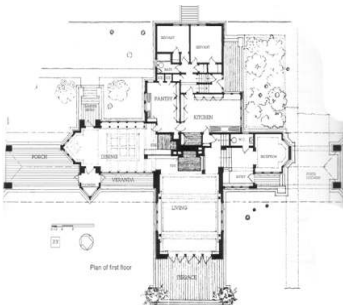

Willitts House, Highland Park, ILL, 1902

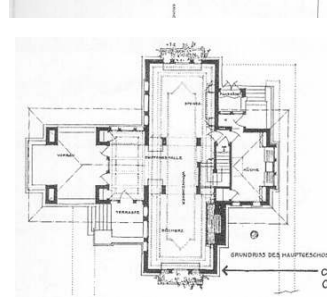

FLW, Barton Hse., Buffalo, 1904

Martin House Overlapping Zones

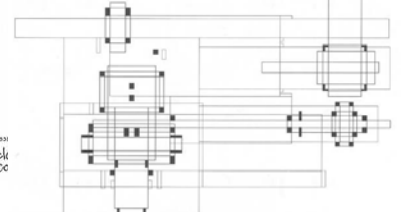

Martin House, Whole Estate

# BREAKING THE BOX

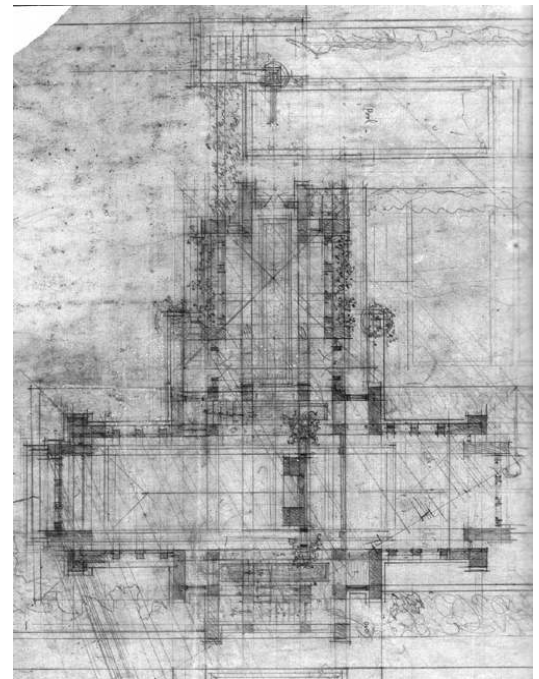
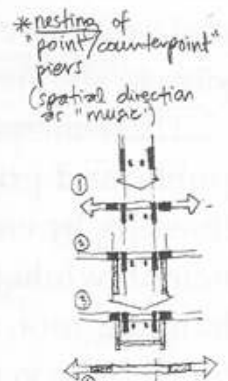
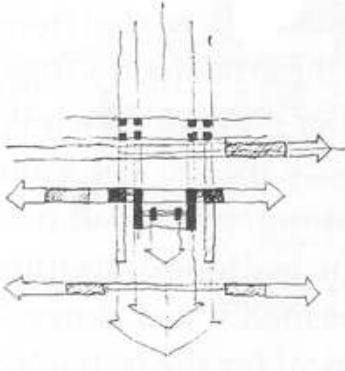
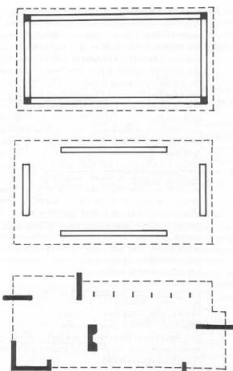
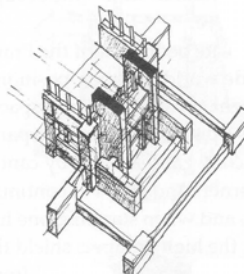
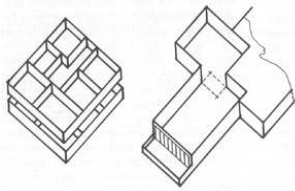
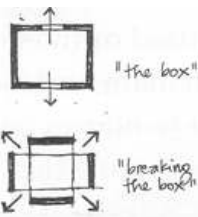

Ullman House (Proj.), 1904, Plan with "process"