

# Locating and Sizing Smart Meter Deployment in Buildings

Anand Krishnan Prakash  
Uddhav Arote

Vivek Chil Prakash  
Pallab Kumar Sahu

Bhavin Doshi  
Krithi Ramamritham

Department of Computer Science and Engineering  
Indian Institute of Technology, Bombay

## ABSTRACT

The use of smart-meters is proliferating, they are now being deployed without asking the obvious question: Do we really need each of them? Beyond the cost of smart-meters, there are overheads related to installation, wiring, etc. To formally tackle this question, we first define the notion of observability that one or more pieces of information (including that from smart-meters) enable. This notion allows us to compare two different deployments of sensors with respect to their information content and their usefulness. We then examine some commonly available information from which one can infer power consumption of devices in a given space. We show how we have applied this approach to systematically decide the optimal number and location of smart-meters to ensure observability of consumption by different parts of a building.

## General Terms

Smart Energy

## Keywords

Smart metering; Energy consumption; Optimal location

## 1. INTRODUCTION

Figure 1 shows the power consumption pattern for a typical week for our building as collected by the smart-meter attached to our building. The total energy consumption during this observation period is dominated by the base power consumption – the minimum power consumption present at any given time, which was 80KW. Concerned by the fact that (a) the instantaneous base consumption is about 50% of the peak and (b) the base energy consumption is about 80% of the aggregate consumed during this period, we wanted to develop the necessary tools to analyze and determine the reasons and also try to reduce the consumption. This case study motivated our research and we were interested in finding the answers to the following questions:

i) Where should we locate a tranche of smart-meters for maximum visibility of a building's power consumption? ii)

Permission to make digital or hard copies of part or all of this work for personal or classroom use is granted without fee provided that copies are not made or distributed for profit or commercial advantage, and that copies bear this notice and the full citation on the first page. Copyrights for third-party components of this work must be honored. For all other uses, contact the owner/author(s). Copyright is held by the author/owner(s).

*e-Energy '15*, July 14–17, 2015, Bangalore, India.

ACM 978-1-4503-3609-3/15/07.

<http://dx.doi.org/10.1145/2768510.2770950>.

How can we capitalize on different areas having the same profile? iii) What are the other readily available information which can be used to infer consumption? iv) Can we develop an incremental approach of installation in which the building manager is not burdened with huge initial investments?

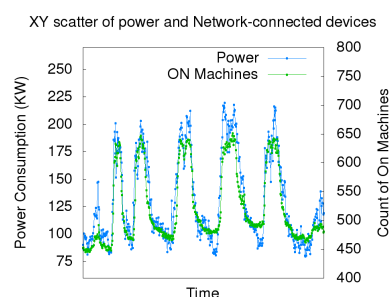

Figure 1: Plot of Power Consumption and Network-Connected Device in our building

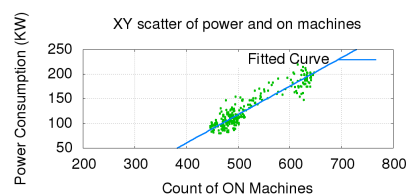

Figure 2: Correlation Between Power Consumption and Network-Connected Device in our building

On further diagnosis, we found that 13KW of the 80KW is attributed to on-but-idle desktop computers. This motivated us to reduce the base consumption by focusing on such machines. By running an arp-scan every 15 minutes, we determined the total number of connected devices which had a strong correlation with power consumption of the building as shown in Figure 1 and Figure 2. Hence data sources like arp-scan, calendar data, biometric attendance etc, along with parameterized consumption models can help infer power consumption of the observed space.

## 2. THE FORMAL BUILDING BLOCKS

### 2.1 The Notion of Observability

A node is any location in a building which is required to be monitored (eg: room, floor). The user defines a notion of observability as per his requirement which can be in terms of number of appliances or occupants or the power consumption observed by the node. Meters are placed in the decreasing order of the notion to ensure maximum observability.

## 2.2 Soft Sensors

Soft Sensors are other readily available information which we can use to infer power consumption of a node. They have to be initialized and tuned with the real power measurement data. Once tuned, the soft-sensor can replace a smart-meter for all practical purposes. For example, from Figure 2, it can be seen that we use number of ON machines as a soft sensor to infer power consumption via the equation:  
 Power (in KW) = 0.577 x Machines - 170.611

## 3. RULES AND ALGORITHMS

### 3.1 Rules for Determining Observability

If a node is observable,  $Observable(N) = True$ , else False.  
**Rule 1:** A node is observable if it has either a physical meter or soft-sensors installed. It measures the aggregate consumption of appliances present in the node (if it is a leaf node) or the leaf nodes in its subtree (if it is a non-leaf node).  
**Rule 2:** If all the children of a node  $N$  are observable, then that node becomes observable.  
**Rule 3:** For a node  $M$ , if the parent node and all its siblings are observable, then it is observable.  $Parent(M) = N$

### 3.2 Identifying Observable States of Nodes

**Initialization:** From Rule 1,  $Observable(N)$  is true if it has a smart-meter or a soft-sensor installed at that node.  
**Bottom Up Pass:** From Rule 2,  $\forall C \in Children(N)$   $Observable(C) \implies Observable(N)$ .  
**Top Down Pass:** From Rule 3, if  $Parent(M) = N$ ,  $Observable(N) \wedge \forall C \in Siblings(M) Observable(C) \implies Observable(M)$ .

### 3.3 Algorithm for Locating Smart-meters

When we have sufficient number of smart-meters, place them at each of the leaf nodes. Otherwise follow Algorithm 1 for maximizing the observability.

---

#### Algorithm 1: Meter Placement Algorithm

---

```

Install soft-sensors where applicable
Apply state identification
for each level of the tree (from root)
    while more unobserved node at current level
        Select an unobserved node with maximum observability
        if more metering instruments available
            if current node is unobserved and is not
                the last unobserved child of its parent
                put a meter on the current node
            else
                continue to next level of tree
    
```

---

### 3.4 Errors

As with every measuring device, smart-meter outputs also have an error component. When the consumption readings of one node is derived from other nodes, this error adds up. If it exceeds the error bound on that particular node, install a smart-meter there. A larger error would have to be dealt with in the case of soft-sensors. Different error bounds would produce different placements.

## 4. METER PLACEMENT IN A BUILDING

Figure 3 depicts the electrical distribution of our CSE Department building and shows the result of applying the meter placement algorithm. From the source, the electrical

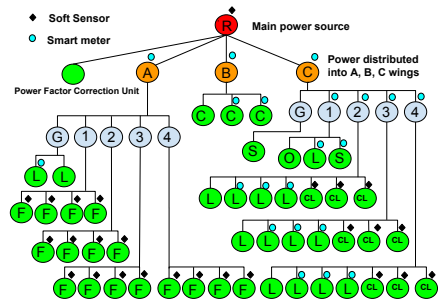

Figure 3: Meter placement with soft-sensors

system at the main power supply divides into three lines (each line with 3 phases), which supplies to the three wings A, B and C. A wing houses the Faculty offices (F), B wing conference rooms (C) and C wing classrooms (CL), office (O), server rooms (S) and labs (L).

Number of Meters at each node	61
Number of Meters at leaf node	47
Number of Meters given soft-sensors	21

Table 1: Number of meters required with various deployment techniques

When we have sufficient meters, we place them directly at each of the leaf nodes. In the case of insufficient meters, we start placement from root node R and follow the Algorithm 1 for meter placement. Soft-sensors can be used at faculty offices and classrooms. An occupancy detector sensor is sufficient because if the faculty/class is present, it has a more or less constant consumption. As can be inferred from Figure 2, number of ON machines is used as a soft sensor instead of placing smart-meter at the root node. This further reduces the number of meters required. As it can be seen from Table 1, the number of meters required for the full observability reduces significantly with the use of soft-sensors and optimal placement algorithm.

## 5. CONCLUSIONS AND APPLICATIONS

In this paper, we present an algorithm to optimally place smart-meters in a building without compromising on the observability using minimum number of smart-meters. We also show that by using soft-sensors this number can be reduced even further, albeit with lesser accuracy. Following are few of the applications of such a placement of meters:

- **Detecting and locating anomalies:** After anomaly detection in the root node meter, with multiple smart-meters, we can follow this anomaly upto the leaf nodes and localize the anomalous appliance, without requiring any occupant information as in [1].
- **Theft location:** Smart-meter deployments aid in detection of possible theft of power. An abnormally high consumption that cannot be accounted for in any node points to theft.

## 6. REFERENCES

- [1] K. Palani, N. Nasir, V. C. Prakash, A. Chugh, R. Gupta, and K. Ramamritham. Putting smart meters to work: Beyond the usual. In *Proceedings of the 5th International Conference on Future Energy Systems, e-Energy '14*, pages 237–238, New York, NY, USA, 2014. ACM.