



Bureau of Grant Applications
Project Proposal November 15, 2006



Table of Contents

| | | |
|-------|---|----|
| 1 | Bureau of Grant Applications | 3 |
| 1.1 | Issues..... | 3 |
| 1.2 | Current Hardware and Network..... | 4 |
| 2 | New Enterprise Architecture, November 15, 2006..... | 5 |
| 2.1 | Business Processes..... | 5 |
| 2.2 | Use Cases | 6 |
| 2.2.1 | Enter RFP into System..... | 7 |
| 2.2.2 | Apply for a Grant | 8 |
| 2.2.3 | Process Grant Applications..... | 9 |
| 2.2.4 | Review Grants..... | 10 |
| 2.2.5 | Notify Applicants..... | 11 |
| 2.2.6 | Manage Grants | 13 |
| 2.2.7 | Update Grant Information..... | 15 |
| 2.2.8 | Get Status of Grant..... | 16 |
| 2.2.9 | Submit Reports..... | 17 |
| 2.3 | Grant Application Program of Projects..... | 18 |
| 2.3.1 | Grant Application Database | 18 |
| 2.3.2 | Program Security | 18 |
| 2.3.3 | Applicant Interface..... | 19 |
| 2.3.4 | Grant Processing and Management | 19 |
| 2.4 | Logical Architecture | 21 |
| 2.5 | Analysis Model | 22 |
| 2.6 | Grant Application Program Components..... | 23 |
| 2.7 | Proposed New Hardware and Network..... | 24 |



1 Bureau of Grant Applications

Our current method for handling grant applications is a labor intensive, error prone process using paper forms and a Wang mainframe with DB2 and CICS. We desire to make changes to the Enterprise Architecture to allow for a more efficient, and yet secure, process. We also have a need to make changes to satisfy current regulatory requirements of the Federal Government.

We are a small agency, about 20 people. We do not handle financial or medical information.

1.1 Issues

1. We need improved security of our systems. Current regulations require us to isolate the HR/Payroll system from the main network, only allowing access to people with the need to know.
2. We also need better security in the interface to the World Wide Web. We need to avoid having hackers access the grant data.
3. We want a more automated process. This is possible with the Wang mainframe by providing a translation layer between the mainframe and more modern software tools. Over time, it is preferable to have a modern database server that communicates more efficiently with other software (rather than going through a translation layer each time we need to access the database).
4. We want to accept grant applications electronically and allow applicants to manage their grants electronically. This would include submitting status reports, updating applicant information, and getting status on the process of their applications electronically.
5. We do not want to convert the whole DB2 database to a new database. However, we continue to need access to the data on the Wang. We would like to continue to manage current grants under the old process, but put any new grants into a new system. When the old grants are complete, then the data on the Wang should become read-only as an archive of information about past grants and applicants.
6. We have no need today for employees to access the systems outside of work, nor do we need a wireless network. These may be needs in the future.

1.2 Current Hardware and Network

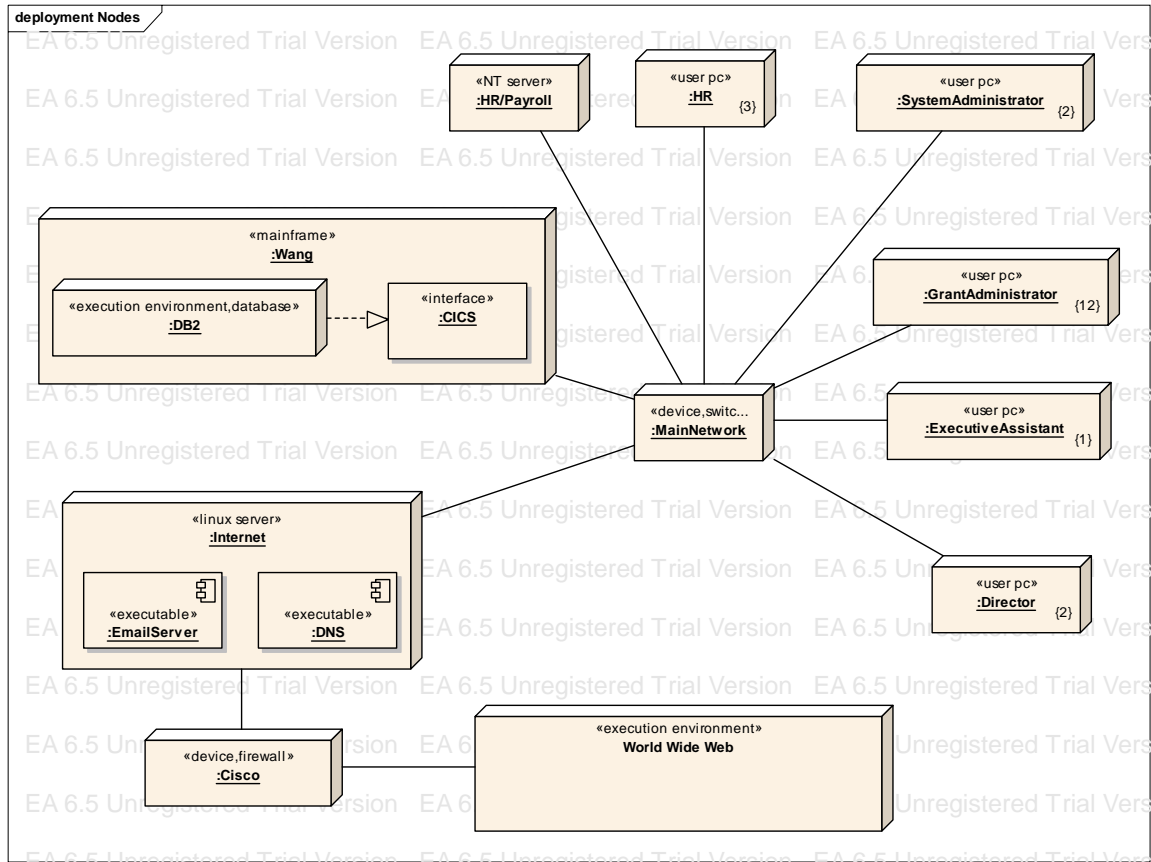

2 New Enterprise Architecture, November 15, 2006

2.1 Business Processes

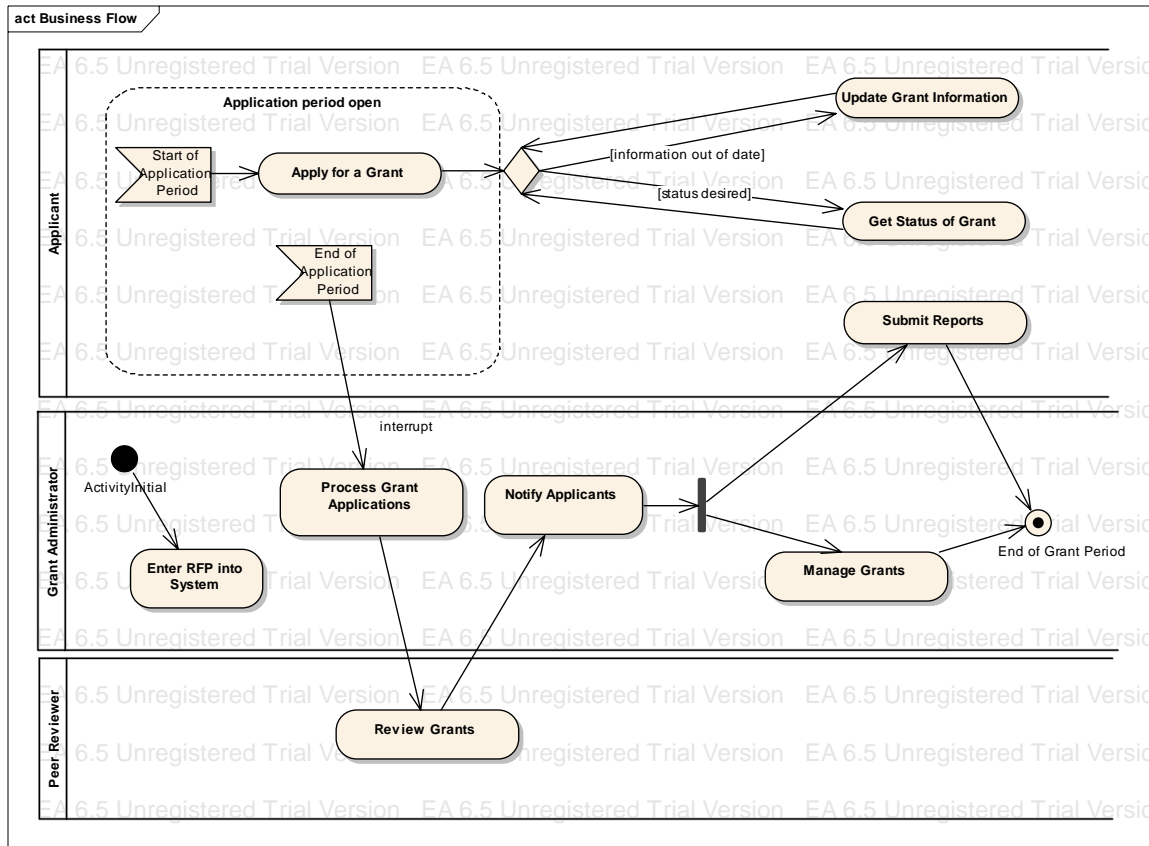

2.2 Use Cases

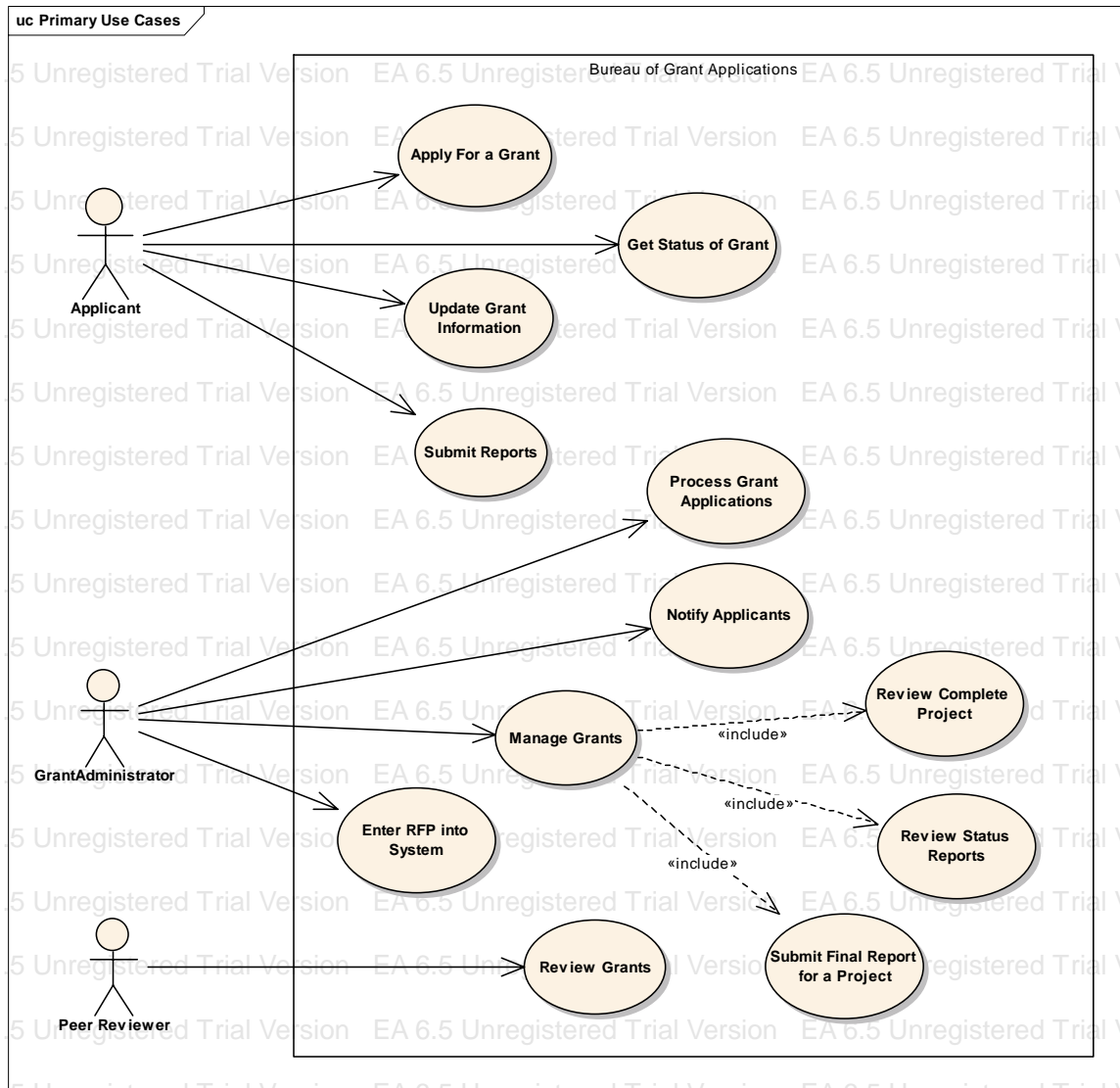

2.2.1 Enter RFP into System

1. The grant administrator opens a Request for Proposal (RFP) information form.
2. The grant administrator enters the terms of the RFP, the application open date, the application close date, and grant administrator contact information.
3. The grant administrator submits the RFP to the system.
4. The system saves the RFP into the database.

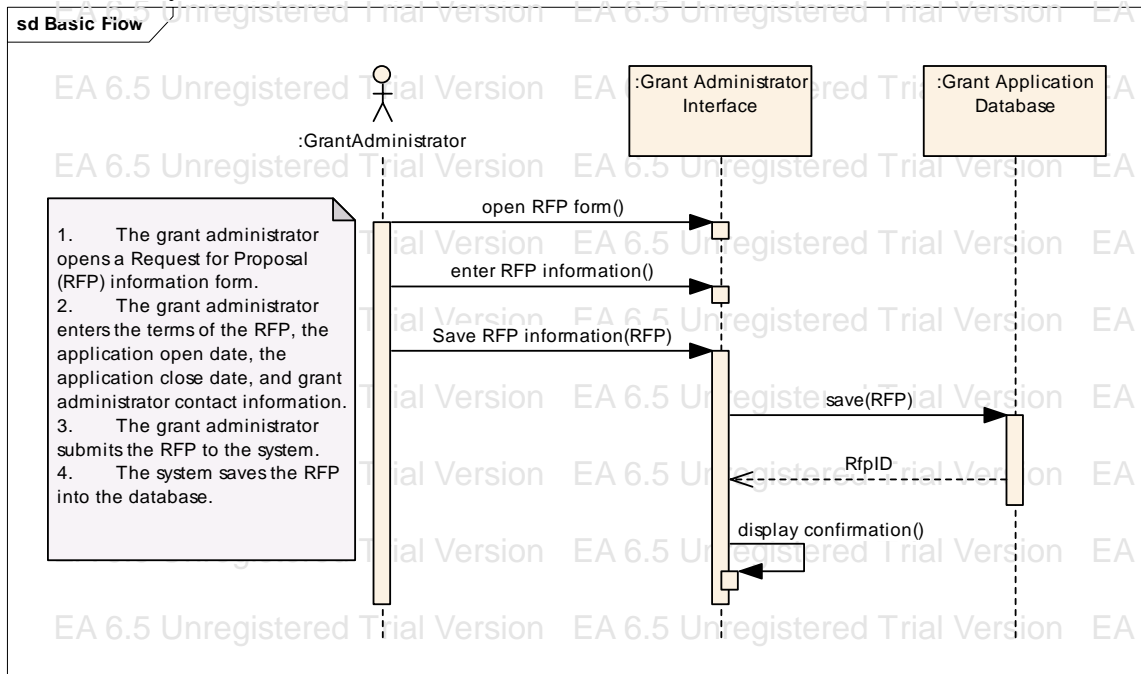



2.2.2 Apply for a Grant

Precondition: The grant application period is open.

1. The applicant opens the grant application at the Bureau of Grant Applications website.
2. The applicant enters required information into the grant application.
3. The applicant submits the grant application to the Bureau of Grant Applications.
4. The system enters the required information into the database in the state of complete.
5. The system sends a confirmation message to the applicant.

Alternatives:

Grant information is incomplete

In step 3 of the use case, if the grant application does not contain all required information, the system posts a message to the applicant requesting the missing information. The use case continues at step 2.

Save

At any time before the applicant submits the grant application, the applicant may choose to save the application in an unfinished state. The system enters the required information into the database in the state of incomplete. The system sends a confirmation message to the applicant.

Cancel

At any time before the applicant submits the grant application, the applicant may choose to cancel the application. The system sends a confirmation message to the applicant.

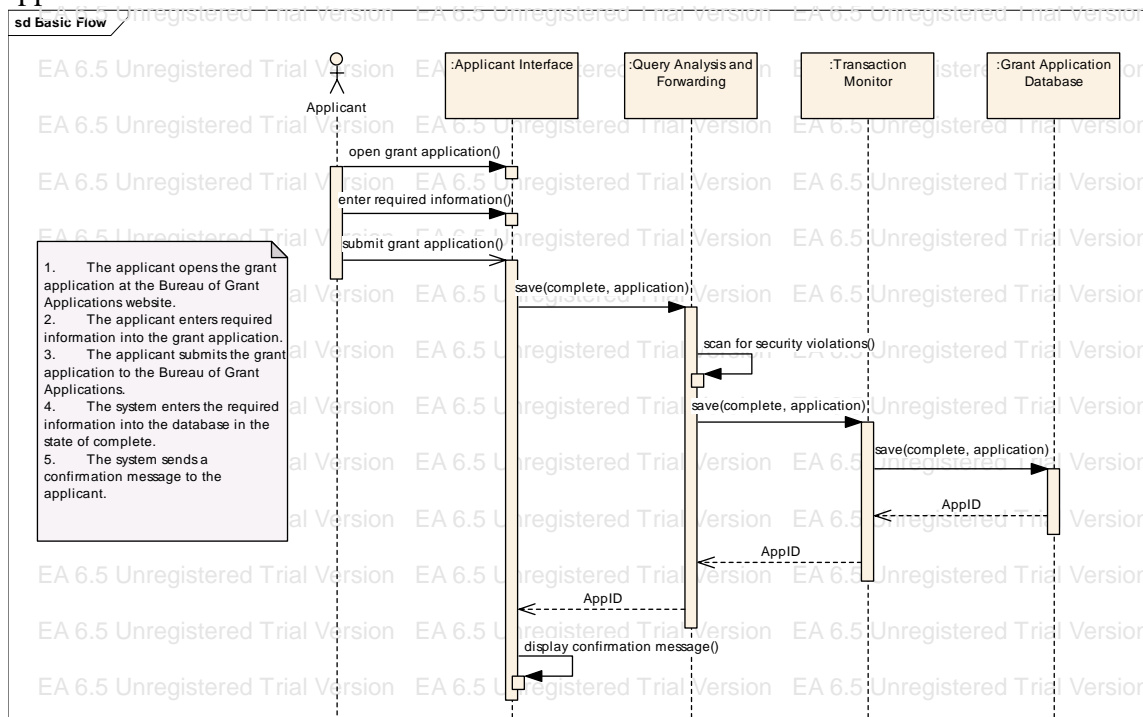

2.2.3 Process Grant Applications

Precondition: The grant application period is closed.

1. The grant administrator queries the system for all grant applications for a particular Request for Proposal (RFP).
2. The grant administrator reviews all of the grant application and evaluates each one against the RFP.
3. If a grant proposal does not meet the basic requirements for the RFP, the grant administrator saves the grant application in the state of rejected.
4. The grant administrator notifies the peer review committee that proposals are ready for review.

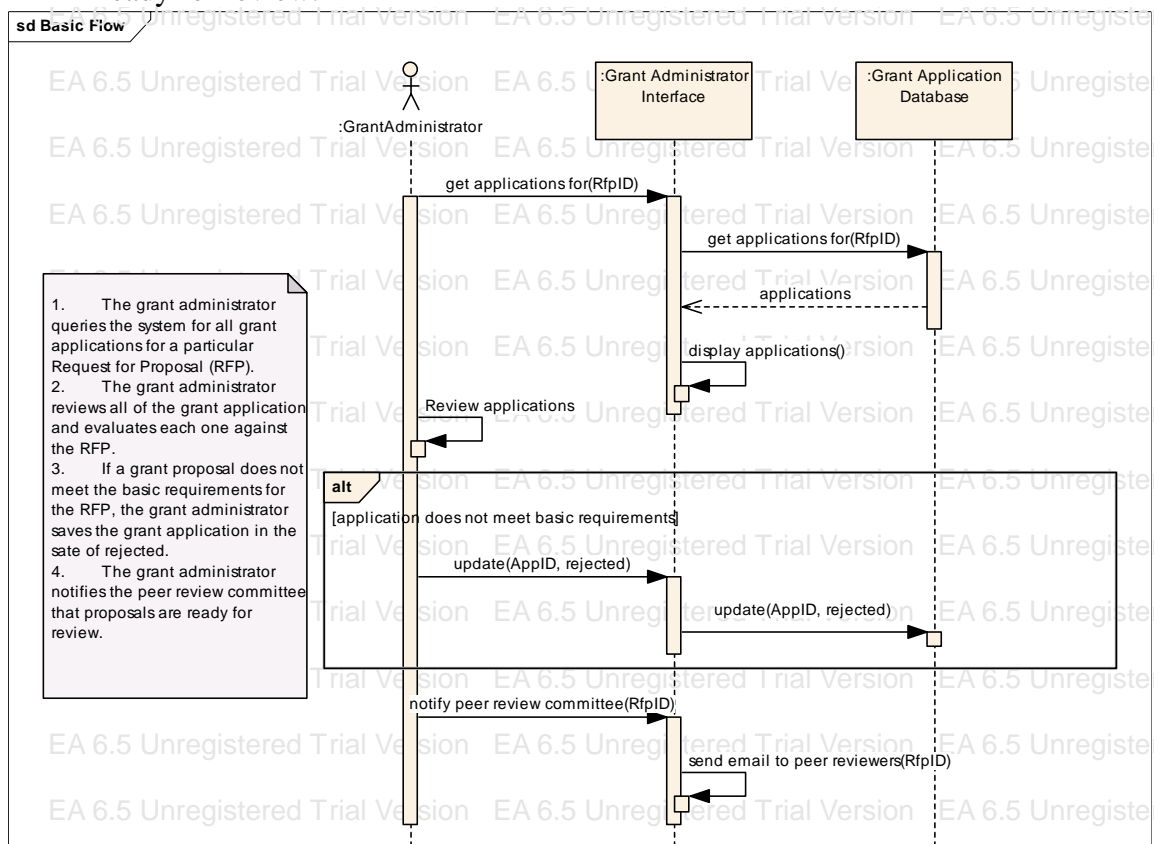

2.2.4 Review Grants

Precondition: Proposals are ready for review.

1. The peer review committee reviews the grant applications.
2. The peer review committee adds comments to each grant application.
3. The peer review committee selects a number of grant applications to be funded as specified in the RFP.
4. The peer review committee saves the selected grant applications in the state of selected.
5. The peer review committee saves the other grant application in the state of non-selected.
6. The peer review committee sends a review complete message to the grant administrator.

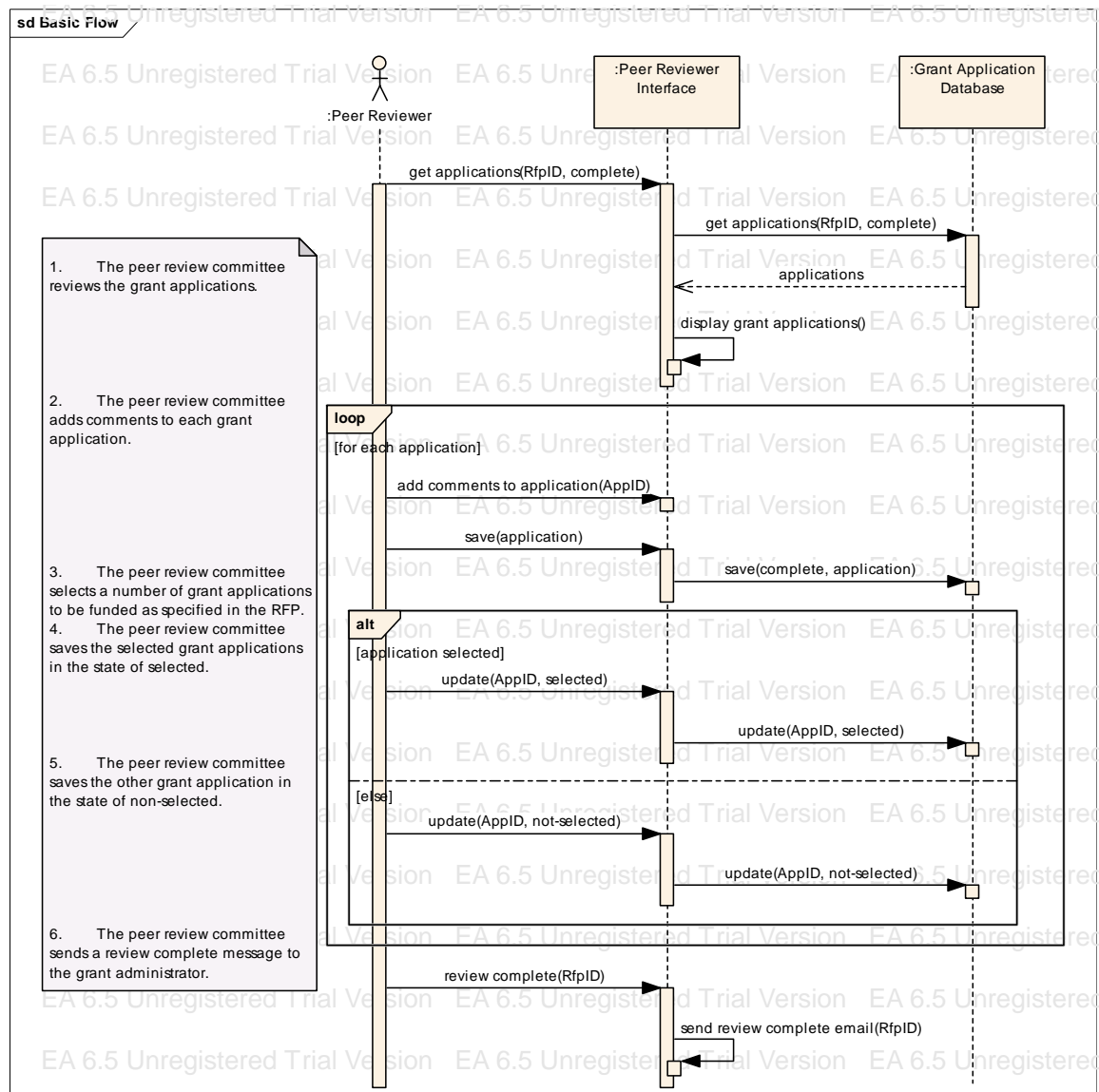



2.2.5 Notify Applicants

Precondition: The peer reviews are complete.

1. The grant administrator directs the system to generate a rejected letter for each rejected application for the RFP.
 - a. The system prints out a letter for each application stating that the reason for the rejection was non-compliance with the terms of the RFP.
 - b. The grant administrator mails the rejection letters to the applicants.
2. The grant administrator directs the system to generate a not-selected letter for each not-selected application for the RFP.
 - a. The system prints out a letter for each application stating that proposal was not selected and inviting the applicant to apply again the next cycle.
 - b. The system prints the peer review committee comments for this application.
 - c. The grant administrator mails the letter and comments to each applicant.
3. The grant administrator directs the system to generate a selected letter for each selected application for the RFP.
 - a. The system prints out a letter for each application stating that the proposal was selected, welcoming the applicant to the grant program, and giving contact information for the grant administrator.
 - b. The system prints the peer review committee comments for this application.
 - c. The system prints new grant holder information sheets.
 - d. The grant administrator mails all the information to each applicant.

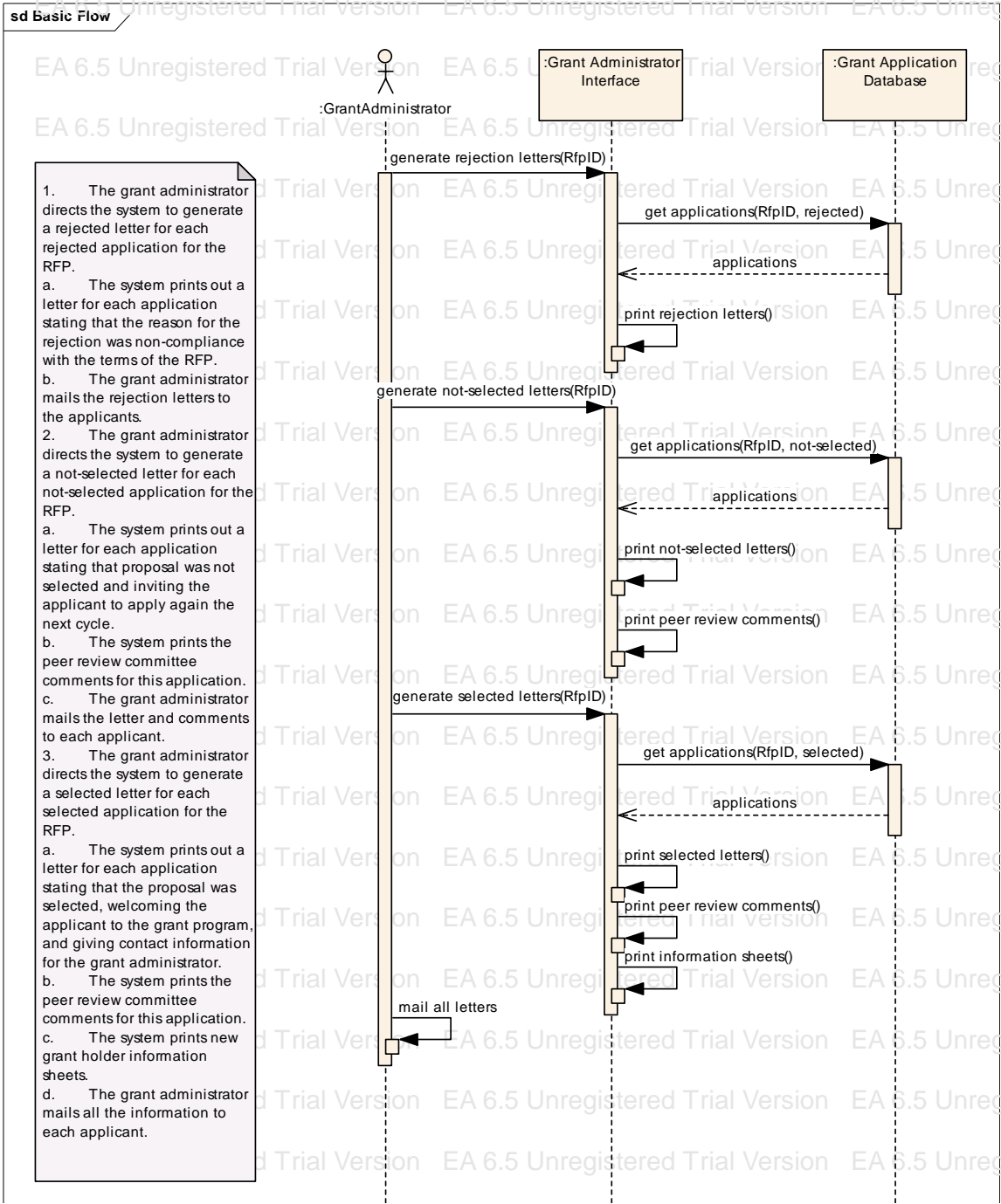



2.2.6 Manage Grants

1. Two weeks after the acceptance letters are sent, the grant administrator calls each applicant to personally welcome him or her to the program.
 - a. The grant administrator requests a time for an initial meeting.
2. In the initial meeting, the grant administrator goes over basic program information.
 - a. The grant administrator sets up a payment schedule with the applicant.
 - b. The grant administrator makes an appointment for an auditor to visit the applicant to certify the applicant's accounting system.
 - c. The grant administrator verifies that the applicant knows the reporting requirements and how to use the online system to enter reports.
3. At the beginning of each month, the grant administrator queries the system for the status report for each grant application in the RFP.
 - a. If a status report is missing, the grant administrator contacts the applicant to submit the report.
 - b. The grant administrator reviews each status report looking for any problems.
 - c. If there are problems, the grant administrator contacts the applicant to find a way to resolve the problems.
4. At the end of the grant schedule, the grant administrator makes an appointment with the applicant to see the final result of the project.
 - a. At the scheduled date, the grant administrator visits the applicant.
 - b. The applicant shows the grant administrator the final result of the project.
5. The grant administrator writes a final report containing his or her impressions of the result of the project in the online report system.
 - a. The system saves the report with the grant application.
6. After all projects have been reviewed, the grant administrator reviews all of the grant applications associated with the RFP.
 - a. The grant administrator writes a report for the agency director containing the results of the projects, and recommendations on whether the RFP was a success or failure, if any of the projects should continue to the next phase of development, and if the RFP should be issued again to get a different set of projects to evaluate.
 - b. The grant administrator closes the RFP in the system.

sd Basic Flow

1. Two weeks after the acceptance letters are sent, the grant administrator calls each applicant to personally welcome him or her to the program.
 - a. The grant administrator requests a time for an initial meeting.
2. In the initial meeting, the grant administrator goes over basic program information.
 - a. The grant administrator sets up a payment schedule with the applicant.
 - b. The grant administrator makes an appointment for an auditor to visit the applicant to certify the applicant's accounting system.
 - c. The grant administrator verifies that the applicant knows the reporting requirements and how to use the online system to enter reports.
3. At the beginning of each month, the grant administrator queries the system for the status report for each grant application in the RFP.
 - a. If a status report is missing, the grant administrator contacts the applicant to submit the report.
 - b. The grant administrator reviews each status report looking for any problems.
 - c. If there are problems, the grant administrator contacts the applicant to find a way to resolve the problems.
4. At the end of the grant schedule, the grant administrator makes an appointment with the applicant to see the final result of the project.
 - a. At the scheduled date, the grant administrator visits the applicant.
 - b. The applicant shows the grant administrator the final result of the project.
5. The grant administrator writes a final report containing his or her impressions of the result of the project in the online report system.
 - a. The system saves the report with the grant application.
6. After all projects have been reviewed, the grant administrator reviews all of the grant applications associated with the RFP.
 - a. The grant administrator writes a report for the agency director containing the results of the projects, and recommendations on whether the RFP was a success or failure, if any of the projects should continue to the next phase of development, and if the RFP should be issued again to get a different set of projects to evaluate.
 - b. The grant administrator closes the RFP in the system.

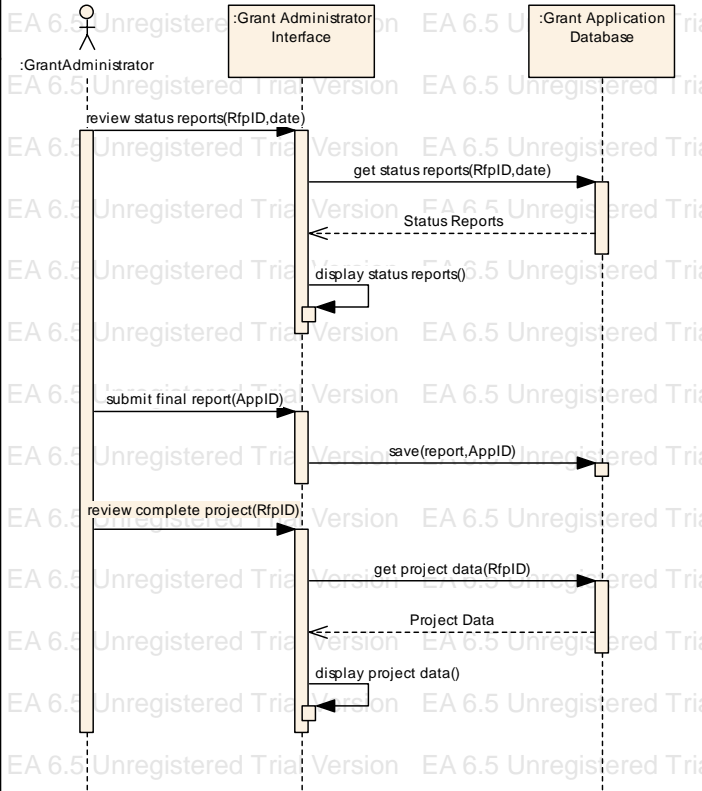

2.2.7 Update Grant Information

1. Any applicant that is accepted into the grant program is responsible for maintaining current information with the agency.
2. If any information on the grant application changes, the applicant enters the new information into the information update system.
3. The system updates the information in the database.

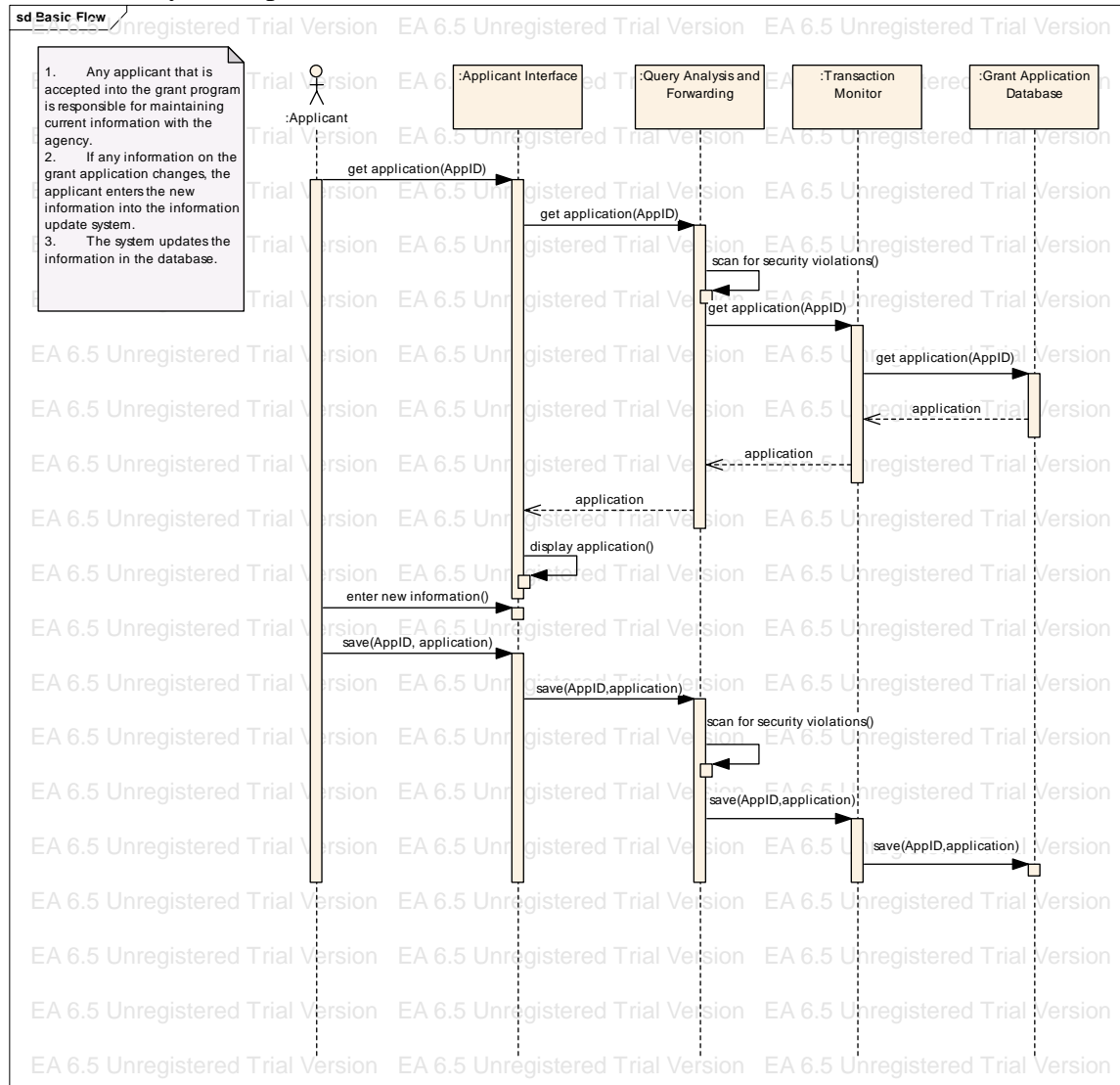

2.2.8 Get Status of Grant

1. At any time, an applicant can get status on their grant application.
2. The applicant queries the system for status on their grant.
3. The system gets the current status from the database.
4. The system displays the current status to the applicant.

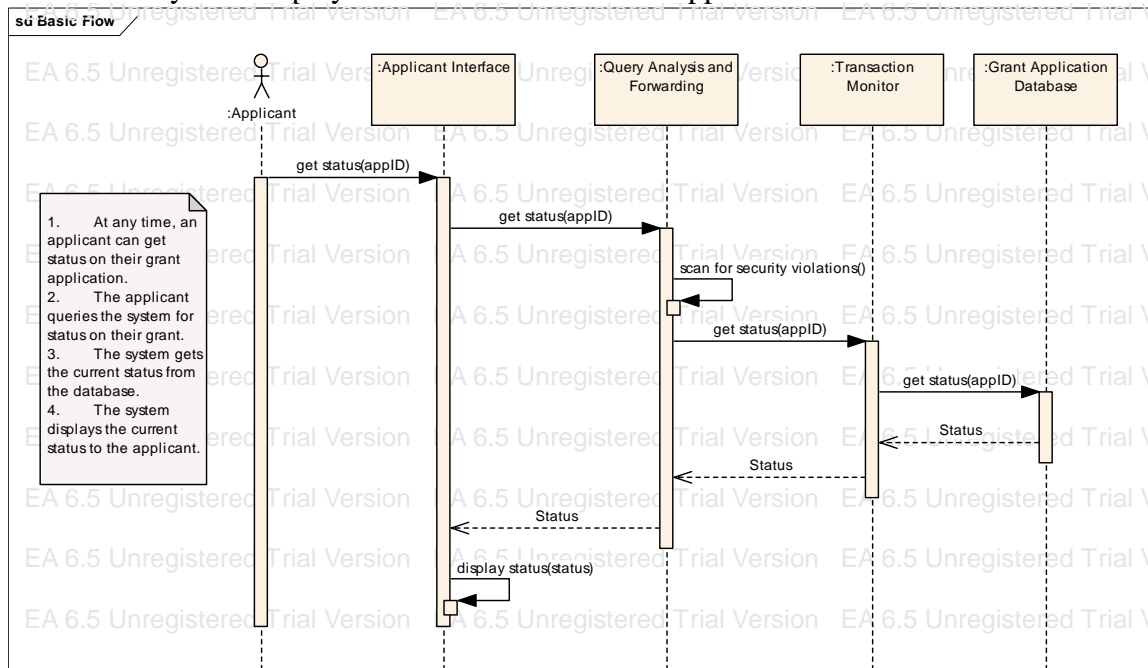

2.2.9 Submit Reports

1. In the first week of each month of the grant, the applicant writes a report on the current status of the project in the online report system.
 - a. The applicant submits the report to the system.
 - b. The system saves the report in the database with the grant application.
2. At the end of the grant schedule, the applicant writes a final status report to the in the online report system.
 - a. The applicant submits the report to the system.
 - b. The system saves the final status report in the database with the grant application.

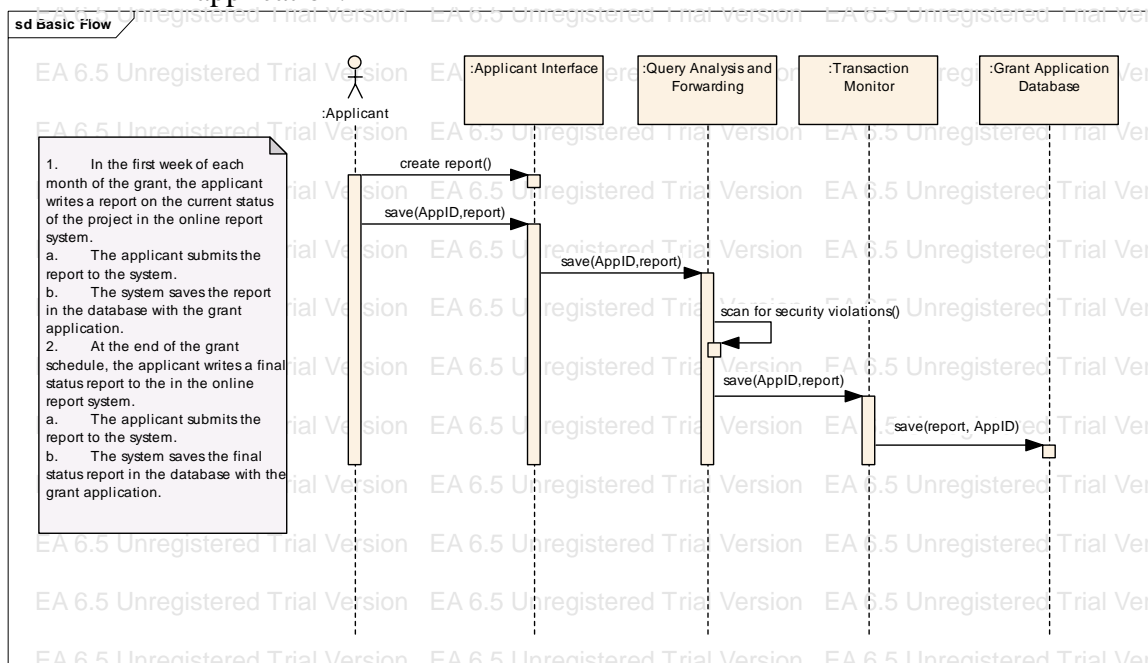



2.3 Grant Application Program of Projects

The grant application program will implement the new grant application process. This program will be composed of the following projects:

2.3.1 Grant Application Database

The Grant Application Database project team is responsible for the following:

1. Installation and configuration of SQL Server – this team must make recommendations on hardware for the Grant Database server and describe any software (in addition to SQL Server) that will be required to support the Grant Application Program
2. Data model for the database for the Grant Application Program
3. Any software required to handle queries and return the requested result
4. Policies for use of the data in the Grant Application Program – some examples include whether to allow caching or not, web services or not, agents or not, stored procedures or not, and any access rules for agency personnel (who is allowed to access the data, update the data, and maintain the database)

From an architecture perspective, this team will describe the following in their SAD:

- The hardware and software required for the database
- The data model for the program
- How queries and responses will be handled (database software, stored procedures, object layer between the database and the program, etc.)
- Database interactions with the Transaction Monitor
- Data policies and mechanisms for the Grant Application Program

2.3.2 Program Security

The Program Security project team is responsible for the following:

1. Interface between web application and database – this team must make recommendations on hardware for the Database Router server and describe any software (in addition to the Transaction Monitor and the Query Analysis and Forwarding software) that will be required to support the Grant Application Program
2. Query analysis and forwarding software – this software gets the queries from the web server, verifies they are legal, and forwards the queries to the Grant Database server
3. Transaction monitor – this team must determine what software will be used for the transaction monitor and how it fits into the program
4. Security policies for the Grant Application Program – some examples include any needs for encryption of data either in the database or when exchanged between systems, whether or not wireless access to the systems should be allowed, whether or not we should allow people to work from home



From an architecture perspective, this team will describe the following in their SAD:

- The hardware and software required for the database router
- Components of the Query Analysis and Forwarding software
- What software will be used for the Transaction Monitor
- Mechanisms for using the Transaction Monitor and Query Analysis and Forwarding software
- Security policies and mechanisms for the Grant Application Program

2.3.3 Applicant Interface

The Applicant Interface project team is responsible for the following:

1. Web browser based forms and instructions for grant applicants to use (application form, update of grant information, status reports, report submission)
2. Policies and guidelines for use of web based technologies for the Grant Application Program – for example, should web browser based applications use software such as AJAX, CGI, Java Script, should the applications generally be thin client or thick client
3. This team must also make recommendations for any software required on the Internet server to support the Grant Application Program

From an architecture perspective, this team will describe the following in their SAD:

- The software required for the Internet server
- Components of the web browser based software for grant applicants to use
- Interactions with the Query Analysis and Forwarding software
- Web technologies policies and mechanisms for the Grant Application Program

2.3.4 Grant Processing and Management

The Grant Processing and Management project team is responsible for the following:

1. Software to allow a grant administrator to enter an RFP, process grant applications, notify applicants, review status reports, manage existing grants on the Wang mainframe. Determine if the software should be web browser based or a Windows application.
2. Software to allow peer reviewers to review and comment on grants. Determine if the software should be web browser based or a Windows application.
3. Any additional hardware and software required for these applications – for example, do we need another server, can these applications run on an existing server (and which one)
4. Directives for phasing out the use of the Wang database for the Grant Application Program
5. User interface policies and mechanisms for the Grant Application Program



From an architecture perspective, this team will describe the following in their SAD:

- Components of the software for grant administrators to use
- Components of the software for peer reviewers to use
- Interactions with the grant application database
- Directives for phasing out the Wang database
- User interfaces policies and mechanisms for the Grant Application Program

2.4 Logical Architecture

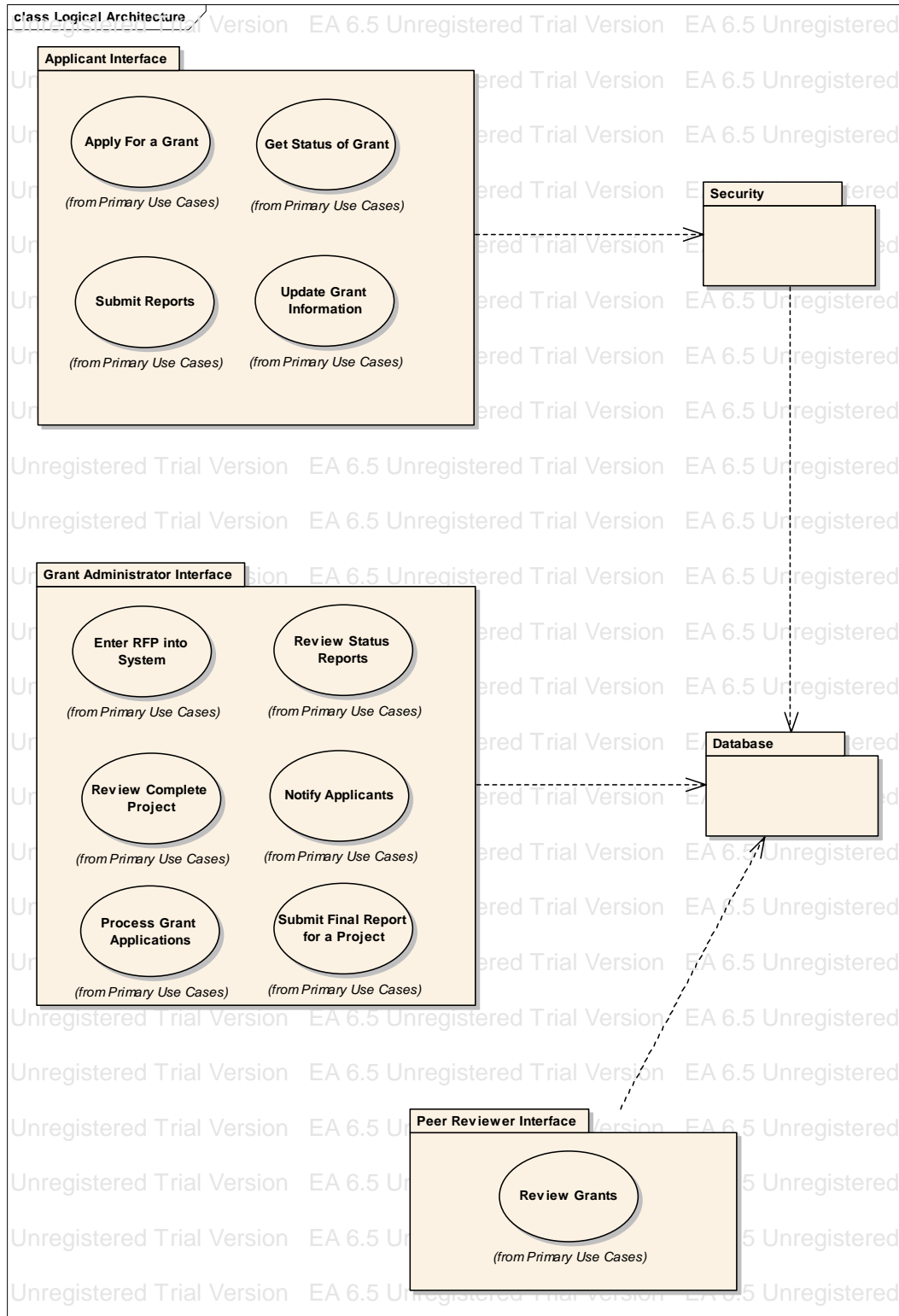

2.5 Analysis Model

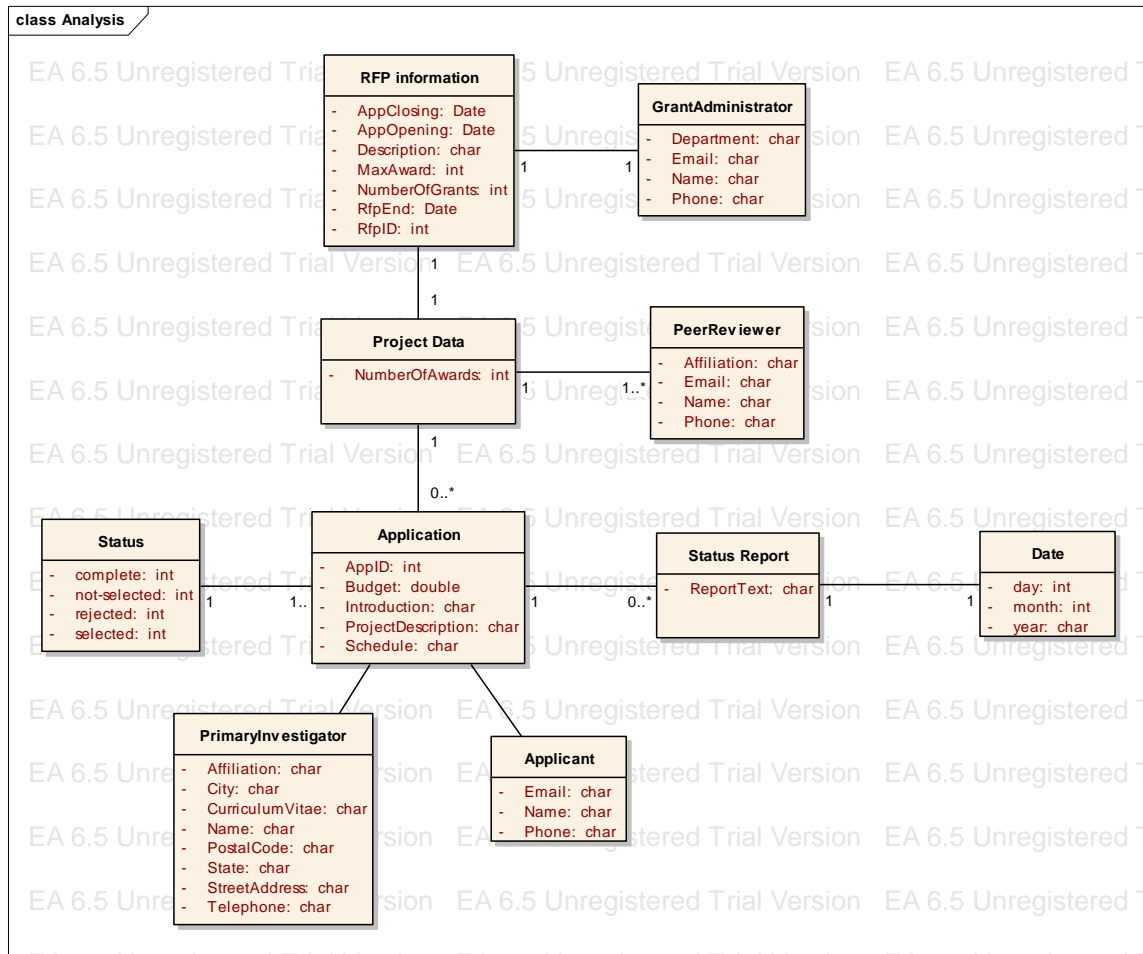

2.6 Grant Application Program Components

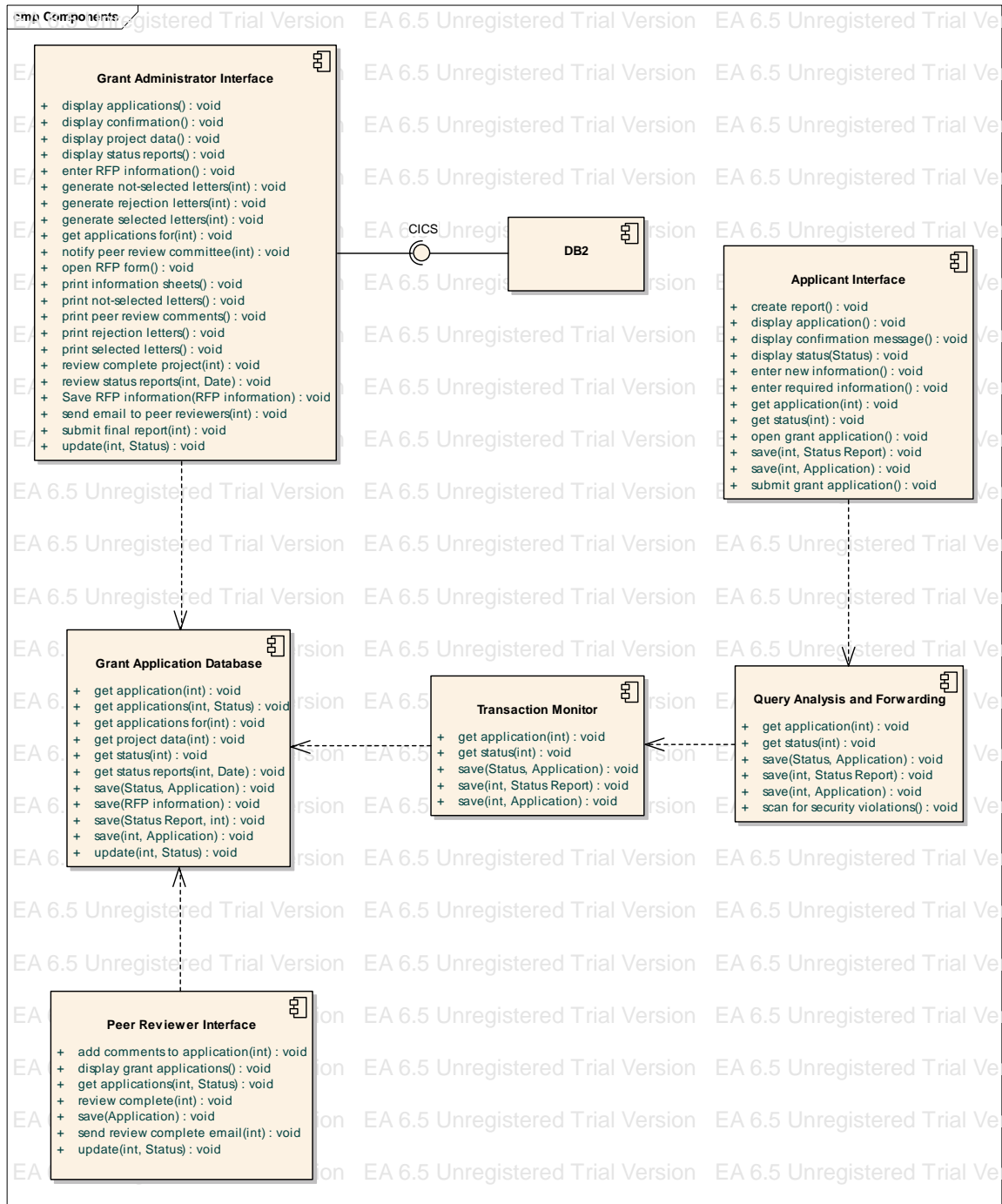

2.7 Proposed New Hardware and Network

