

15-381

Artificial Intelligence

Lecture 2: AI and the Brain

Fall 2010

SPAM

The image shows a screenshot of a Gmail spam folder in a Safari browser. The browser's address bar shows the URL `http://mail.google.com/mail/?hl=en&tab=wm#spam`. The Gmail interface includes a search bar with `in:spam` entered, and a list of spam messages. A large, semi-transparent red text overlay is centered over the list, reading "Cost: \$10B in 2007 (est.)¹". The list of messages includes various spam subjects such as "devis panneaux solaires", "Despin...", "Ashley Michiko", "uzixic...", "Shamika Aracelis", "Scarlett Shane", "Term Life Insurance", "Jerrie...", "Employment...", "joy job...", "ComTechService", "Kitty Missy", "Mrs Elizabeth Rose Jones", "Elvira Josephina", "Tatiana Natalya", "Best Senior Care", "me", "Michal Ayako", "uikaro3076", "Sabrina Darlene", "The Dubai Aquarium and L", and "Cherri Petronila". The messages contain various promotional and scam-like content, including offers for hydrocodone, Viagra, and other products.

IDEA 1: Let's be Rational

Viagra

Hydrocodone

Saudi Prince

Russian Marriage

[REDACTED]

[REDACTED]

[REDACTED]

[REDACTED]

[REDACTED]

[REDACTED]

•
•
•
•

FILTER

Safari File Edit View History Bookmarks Window Help

Gmail - Spam (482) - subail@gmail.com

http://mail.google.com/mail/?hl=en&tab=wm#spam

Google Maps Wikipedia News (1022) Popular

Gmail Calendar Documents Web Reader more

subail@g

Create a Filter

Choose search criteria Specify the criteria you'd like to use for determining what to do with a message as it arrives. Use "Test Search" to see which messages would have been filtered using the criteria. Messages in Spam and Trash will not be searched.

From:

To:

Subject:

Has the words:

Doesn't have:

Has attachment

[Show current filters](#)

Mail

Contacts

Tasks

Compose mail

Inbox

Starred ☆

Sent Mail

Drafts (129)

Spam (482)

[Gmail]Trash

Personal

Travel

5 more ▾

Yaser Sheikh +

Search, add, or invite

Invite a friend -

Spam Swiss Pie - Bake 45-55 minutes or until eggs are set

Delete forever Not spam Move to ▾ Labels ▾ More actions ▾ Refresh

[Delete all spam messages now](#) (messages that have been in Spam more than 30 days will be automatically deleted)

<input type="checkbox"/>	★ devis panneaux solaires	Produire de l'electricité: un revenu assuré pendant 20 ans - Haut Demande de devis En bref Lois & dispositifs Exemples d'installatio
<input type="checkbox"/>	★ Despina Brenna	[REDACTED]
<input type="checkbox"/>	★ Ashlea Michiko	ocp e8is - z
<input type="checkbox"/>	★ uzixicuciq4546	Get the key to Pharaoh's Tomb - Great wild action awaits you with this magical formula http://www.dolldock.ru
<input type="checkbox"/>	★ Shamika Aracelis	Pay Less Buy More! XAMAX pills 60x0.5mg=\$166.80 h0j - Save BIG! Compare XAMAX price in TOP Pharmacy! Don't miss the chan
<input type="checkbox"/>	★ Scarlett Shane	Brand Hydrocodone 30 pills \$260, Brand Hydrocodone Watson 540 30-120 pills packages p18 - HYDROCODONE BRAND Watson
<input type="checkbox"/>	★ Term Life Inurance	Coverage starts immediately - Click Here Now
<input type="checkbox"/>	★ Jerrie Estela	[REDACTED]
<input type="checkbox"/>	★ EmploymentCrossingNew:	The Job Researcher: Pratt & Whitney To Lay off 129 Hourly Employees; Union Vows To Fight - Spam detection software, running
<input type="checkbox"/>	★ joy johnson	Hello, - Greetings With Love, How are you and how is your work? i hope that all is well with you, My name ...
<input type="checkbox"/>	★ ComTechService	[REDACTED]
<input type="checkbox"/>	★ Kitty Missy	[REDACTED]
<input type="checkbox"/>	★ Mrs Elizabeth Rose Jones	STOP CONTACTING THOSE PEOPLE!!! - Spam detection software, running on the system "gondor.cs.ucf.edu", has identified this ...

PROPOSITIONAL LOGIC

SYNTAX

Proposition Symbols: P , Q , ...

Examples:

S : Email is spam

P : “Hydrocodone” is in email

Q : “████████” is in email

R : “Russian” is in email

T : “Marriage” is in email

⋮

PROPOSITIONAL LOGIC

LOGICAL IMPLICATION

Proposition Symbols: P, Q, \dots

Logical Connectives: $\wedge, \vee, \Rightarrow, \Leftrightarrow, \neg$

implies: \Rightarrow

$$P \Rightarrow S$$

“Hydrocodone” is in email implies the email is spam

```
for (all words in email)
  if (word is “Hydrocodone”)
    label email as spam
  quit
```

PROPOSITIONAL LOGIC

OR

Proposition Symbols: P, Q, \dots

Logical Connectives: $\wedge, \vee, \Rightarrow, \Leftrightarrow, \neg$

or: \vee

$$P \vee Q \Rightarrow S$$

“Hydrocodone” or “██████████” is in email implies the email is spam

```
for (all words in email)
  if (word is “Hydrocodone” or word is “██████████”)
    label email as spam
  quit
```

PROPOSITIONAL LOGIC

AND

Proposition Symbols: P, Q, \dots

Logical Connectives: $\wedge, \vee, \Rightarrow, \Leftrightarrow, \neg$

and: \wedge

$$P \wedge Q \Rightarrow S$$

Both “Russian” and “Marriage” is in email, implies the email is spam

```
for (all words in email)
  if (word is "Russian")
    for (all words in email)
      if(word is "Marriage")
        label email as spam
      quit
```

FILTER

The screenshot shows a Gmail search results page for the query "Russian Marriage". The browser is Safari, and the page title is "Gmail - Search results - subail@gmail.com". The search results are displayed in a list format, with the top result being a promotional email for "Russian River Cruises". Below this, there are four search results from NYTimes.com and Omar Javed. The page also includes a sidebar with navigation options like Mail, Contacts, and Tasks, and a bottom section with account information and storage usage.

Search Results:

Source	Subject
NYTimes.com	Today's Headlines: Pursuing U.S. Aid, G.M. Accepts Need for Drastic Cuts
NYTimes.com	Today's Headlines: Georgia Claims on Russia War Called Into Question
NYTimes.com	Today's Headlines: Concerns Raised on Wider Spying Under New Law
Omar Javed	FW: [alumni] A must read about Balochistan

Account Information:

- Storage: 11.2 GB (5%) of 207.3 GB - [Manage](#) or [Upgrade](#)
- This account is open in 2 other locations. Last account activity: 1 hour ago on this computer. [Details](#)
- Gmail view: standard | [turn off chat](#) | [turn on buzz](#) | [older contact manager](#) | [older version](#) | [basic HTML](#) | [Learn more](#)

PROPOSITIONAL LOGIC

SYNTAX

Proposition Symbols: P , Q , ...

Examples:

S : Email is spam

P : "Hydrocodone" is in email

Q : "████████" is in email

R : "Russian" is in email

T : "Marriage" is in email

N : "NYTimes.com" is in email

⋮

PROPOSITIONAL LOGIC

NOT

Proposition Symbols: P, Q, \dots

Logical Connectives: $\wedge, \vee, \Rightarrow, \Leftrightarrow, \neg$

not: \neg

$$P \wedge Q \wedge \neg N \Rightarrow S$$

Both “Russian” and
“Marriage” is in email and
“NYTimes.com” is not in
email, implies the email is
spam

```
for (all words in email)
  if (word is "Russian")
    for (all words in email)
      if(word is "Marriage")
        for (all words in email)
          if(word is "NYTimes.com")
            quit
        label email as spam
      quit
```

TRUTH TABLE

P	Q	$\neg P$	$P \wedge Q$	$P \vee Q$	$P \Rightarrow Q$	$P \Leftrightarrow Q$
FALSE	FALSE					
FALSE	TRUE					
TRUE	FALSE					
TRUE	TRUE					

LOGICAL IMPLICATION REVISITED

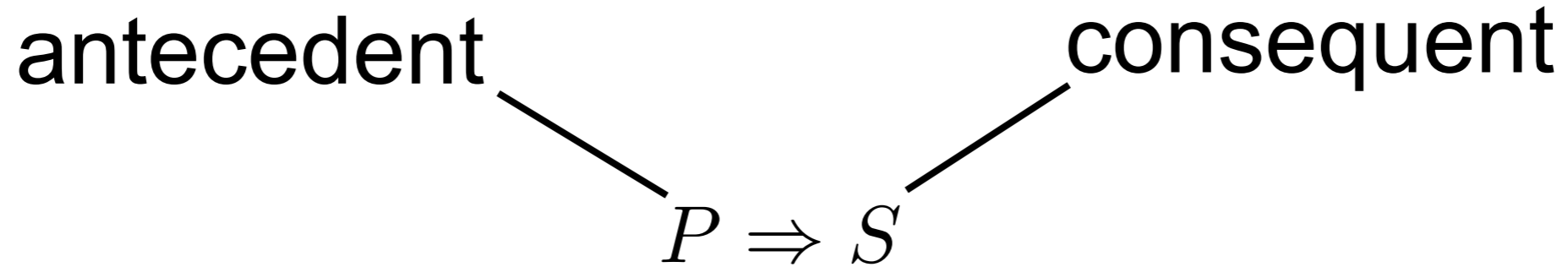

		$P \Rightarrow S$
“Hydocodone” is NOT in email	Email is NOT spam	
“Hydocodone” is NOT in email	Email is spam	
“Hydocodone” is in email	Email is NOT spam	
“Hydocodone” is in email	Email is spam	

TRUTH TABLE

P	Q	$\neg P$	$P \wedge Q$	$P \vee Q$	$P \Rightarrow Q$	$P \Leftrightarrow Q$
FALSE	FALSE	TRUE	FALSE	FALSE	TRUE	TRUE
FALSE	TRUE	TRUE	FALSE	TRUE	TRUE	FALSE
TRUE	FALSE	FALSE	FALSE	TRUE	FALSE	FALSE
TRUE	TRUE	FALSE	TRUE	TRUE	TRUE	TRUE

INFERENCE

$$((P \vee Q) \wedge \neg Q) \Rightarrow P$$

P	Q	$P \vee Q$	$(P \vee Q) \wedge \neg Q$	$((P \vee Q) \wedge \neg Q) \Rightarrow P$
FALSE	FALSE			
FALSE	TRUE			
TRUE	FALSE			
TRUE	TRUE			

INFERENCE RULES

1. Modus Ponens (or Implication-Elimination)

$$\frac{\alpha \Rightarrow \beta, \alpha}{\beta}$$

INFERENCE RULES

2. AND-Elimination

$$\frac{\alpha_1 \wedge \alpha_2 \cdots \wedge \alpha_n}{\alpha_i}$$

INFERENCE RULES

3. AND-Introduction

$$\frac{\alpha_1, \alpha_2 \cdots, \alpha_n}{\alpha_1 \wedge \alpha_2 \cdots \wedge \alpha_n}$$

INFERENCE RULES

4. OR-Introduction

$$\frac{\alpha_i}{\alpha_1 \vee \alpha_2 \cdots \vee \alpha_n}$$

INFERENCE RULES

5. Double-Negation Elimination

$$\frac{\neg\neg\alpha}{\alpha}$$

INFERENCE RULES

6. Unit Resolution

$$\frac{a \vee \beta, \neg\beta}{\alpha}$$

INFERENCE RULES

7. Resolution

$$\frac{a \vee \beta, \neg\beta \vee \gamma}{a \vee \gamma}$$

INFERENCE RULES

1. Modus Ponens
2. AND-Elimination
3. AND-Introduction
4. OR-Introduction
5. Double-Negation Elimination
6. Unit Resolution
7. Resolution

PROP. LOGIC?

Safari File Edit View History Bookmarks Window Help

Gmail - Toyota Burkina Faso Lottery - subail@gmail.com

http://mail.google.com/mail/?hl=en&tab=wm#spam/12a9a3d082fb2eed

Google Maps Wikipedia News (1025) Popular

Gmail Calendar Documents Web Reader more

subail@

Gmail by Google

in:spam Search Mail Search the Web Show search options Create a filter

Mail
Contacts
Tasks

Compose mail

Inbox
Starred
Sent Mail
Drafts (128)
Spam (486)

[Gmail]Trash
Personal
Travel
5 more

Yaser Sheikh
Search, add, or invite

Invite a friend
Give Gmail to:
Send Invite 96 left
Preview Invite

GEICO Auto Insurance - www.GEICO.com - \$100? \$200? \$300? How much could you save? Get an instant quote.

Back to Spam Delete forever Not spam Move to Labels More actions

Toyota Burkina Faso Lottery Spam | X

★ **Toyota Burkina Faso Lottery** show details Aug 17 (7 days ago) Reply

Toyota Burkina Faso Lottery
Customer Service Department
Ouagadougou, Burkina Faso's capital city, West Africa
PRIZE AWARD NOTIFICATION

We are pleased to inform you of the announcement made today, You are among the winners of the TOYOTA CAR INTERNATIONAL PROMOTION PROGRAM Participants were selected through a computer ballot system drawn from 2,500,000 email addresses of individuals and companies from all part of the world as part of our electronic business Promotions Program.As a result of your visiting various websites we are running the E-business promotions for. You/Your Company email address, attached to ticket number 719-226-1319 719-226-1319 , with serial number 902-66 drew the lucky numbers 05,12,30,11,17,43 and Bonus number 10 , Your INSURANCE Number: FLS433/ 453L /GMSA and consequently you won in the Second Category of the TOYOTA FORTUNE LOTTO DRAW.You have therefore been approved for the payment of the sum of US\$1,000, 000, 00 in cash, including a Toyota car which is the winning present /amount for the Second category winners. This is from the total prize money of US\$12,650,000.00 shared among the i ategy.CONGRATULATIONS!!!

Please be informed that your won fund of the sum of US\$1,000,000.00 is now with the payee center. Contact our agent and give them your full names so that they will re-insure your winning fund under your full names. Together with the port where your winning car should be shipped to.To begin your claim, please call our claim agent or send email immediately to:-

GIBSON DAVID
Foreign Services Manager,
Transglobe Finance Securities
E-mail:lottery-car@voila.fr
Tel:00226-75346635

1. Full Name:
2. Address:
3. Occupation:
4. Age:
5. Sex:
6. Nationality:
7. Country of Residence:
8. Telephone/Fax Number:



formerly
République de Haute-Volta
Burkina Faso



TRUTH TABLE

Safari File Edit View History Bookmarks Window Help

Gmail - Toyota Burkina Faso Lottery - subail@gmail.com

http://mail.google.com/mail/?hl=en&tab=wm#spam/12a9a3d082fb2eed

Google Maps Wikipedia News (1025) Popular

Gmail Calendar Documents Web Reader more

subail@g

Gmail by Google

in:spam Search Mail Search the Web Show search options Create a filter

Mail
Contacts
Tasks

Compose mail

Inbox
Starred ☆
Sent Mail
Drafts (128)
Spam (486)

[Gmail]Trash
Personal
Travel
5 more ▾

● Yaser Sheikh +
Search, add, or invite

Invite a friend -
Give Gmail to:
Send Invite 96 left
Preview Invite

GEICO Auto Insurance - www.GEICO.com - \$100? \$200? \$300? How much could you save? Get an instant quote.

« Back to Spam Delete forever Not spam Move to ▾ Labels ▾ More actions ▾

Toyota Burkina Faso Lottery Spam | X

☆ **Toyota Burkina Faso Lottery** show details Aug 17 (7 days ago) Reply ▾

Toyota Burkina Faso Lottery
Customer Service Department
Ouagadougou, Burkina Faso's capital city, West Africa
PRIZE AWARD NOTIFICATION

We are pleased to inform you of the announcement made today, You are among the winners of the TOYOTA CAR INTERNATIONAL PROMOTION PROGRAM Participants were selected through a computer ballot system drawn from 2,500,000 email addresses of individuals and companies from all part of the world as part of our electronic business Promotions Program.As a result of your visiting various websites we are running the E-business promotions for. You/Your Company email address, attached to ticket number 719-226-1319 719-226-1319 , with serial number 902-66 drew the lucky numbers 05,12,30,11,17,43 and Bonus number 10 , Your INSURANCE Number: FLS433/ 453L /GMSA and consequently you won in the Second Category of the TOYOTA FORTUNE LOTTO DRAW.You have therefore been approved for the payment of the sum of US\$1,000, 000, 00 in cash, including a Toyota car which is the winning present /amount for the Second category winners. This is from the total prize money of US\$12,650,000.00 shared among the i ategy.CONGRATULATIONS!!!

Please be informed that your won fund of the sum of US\$1,000,000.00 is now with the payee center. Contact our agent and give them your full names so that they will re-insure your winning fund under your full names. Together with the port where your winning car should be shipped to.To begin your claim, please call our claim agent or send email immediately to:-
GIBSON DAVID
Foreign Services Manager,
Transglobe Finance Securities
E-mail:lottery-car@voila.fr
Tel:00226-75346635

1. Full Name:
2. Address:
3. Occupation:
4. Age:
5. Sex:
6. Nationality:
7. Country of Residence:
8. Telephone/Fax Number:

IDEA 2

We are pleased to inform you of the announcement made today, You are among the winners of the TOYOTA CAR INTERNATIONAL PROMOTION PROGRAM Participants were selected through a computer ballot system drawn from 2,500,000 email addresses of individuals and companies from all part of the world as part of our electronic business Promotions Program.As a result of your visiting various websites we are running the E-business promotions for. You/Your Company email address, attached to ticket number 719-226-1319 719-226-1319 , with serial number 902-66 drew the lucky numbers 05,12,30,11,17,43 and Bonus number 10 , Your INSURANCE Number: FLS433/ 453L /GMSA and consequently you won in the Second Category of the TOYOTA FORTUNE LOTTO DRAW.You have therefore been approved for the payment of the sum of US\$1,000, 000, 00 in cash, including a Toyota car which is the winning present /amount for the Second category winners. This is from the total prize money of US\$12,650,000.00 shared among the i ategy.CONGRATULATIONS!!!
Please be informed that your won fund of the sum of US\$1,000,000.00 is now with the payee center. Contact our agent and give them your full names so that they will re-insure your winning fund under your full names. Together with the port where your winning car should be shipped to.To begin your claim, please call our claim agent or send email immediately to:-

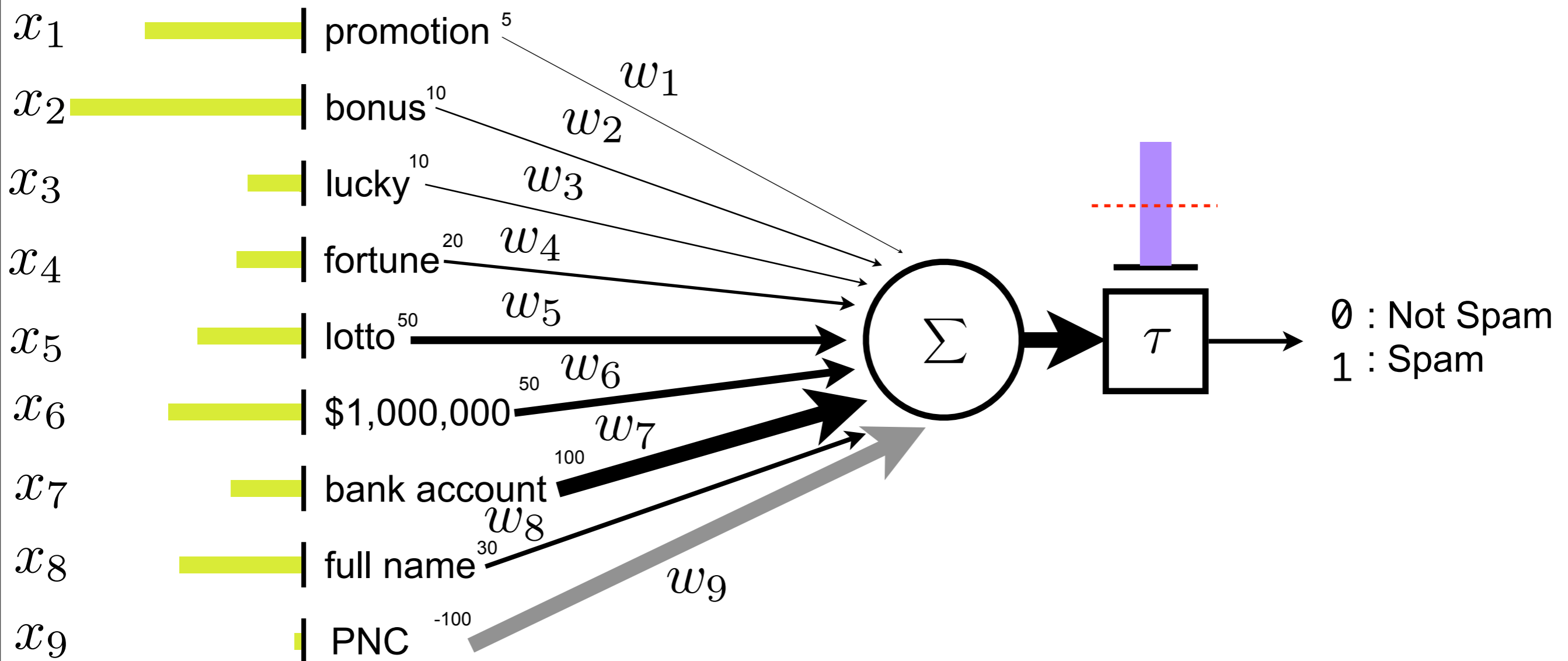

WEIGHTED SUM

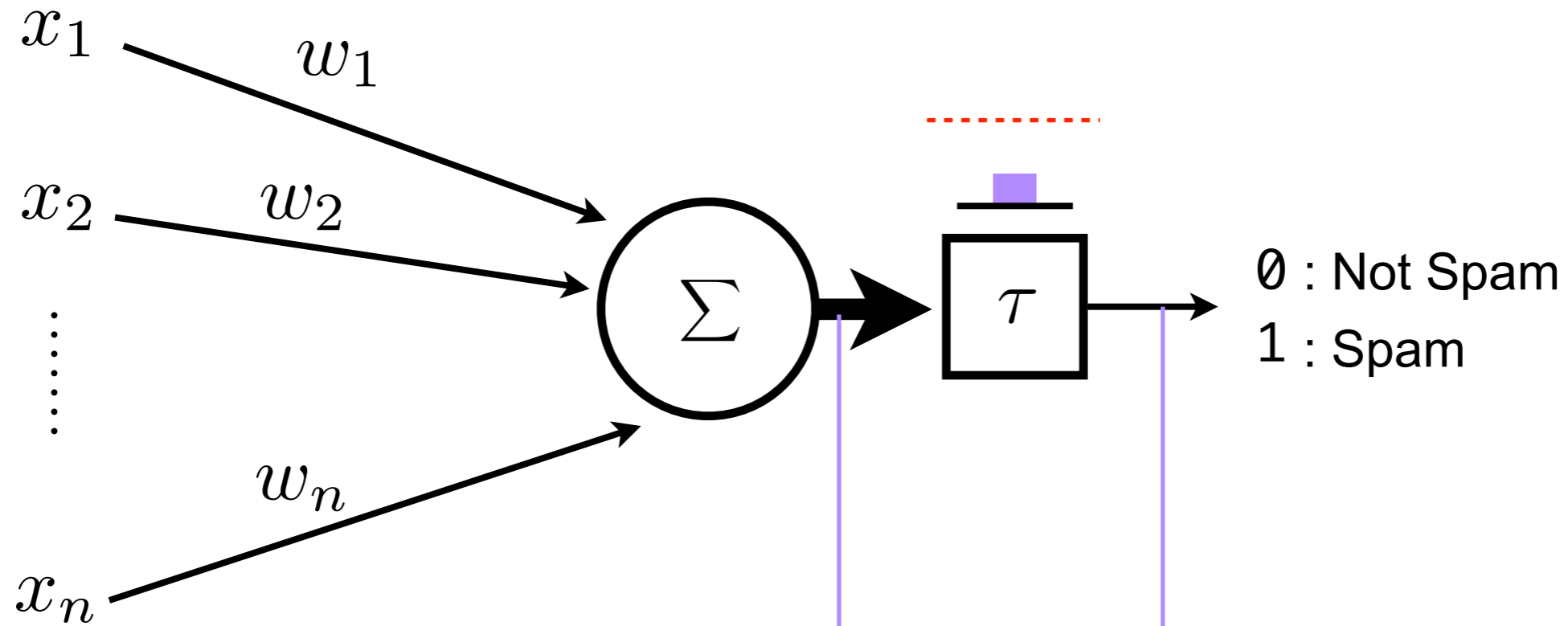

$$w_1x_1 + w_2x_2 + \dots + w_nx_n$$

$$w_1x_1 + w_2x_2 + \dots + w_nx_n \geq \tau$$

Threshold

WEIGHTED SUM

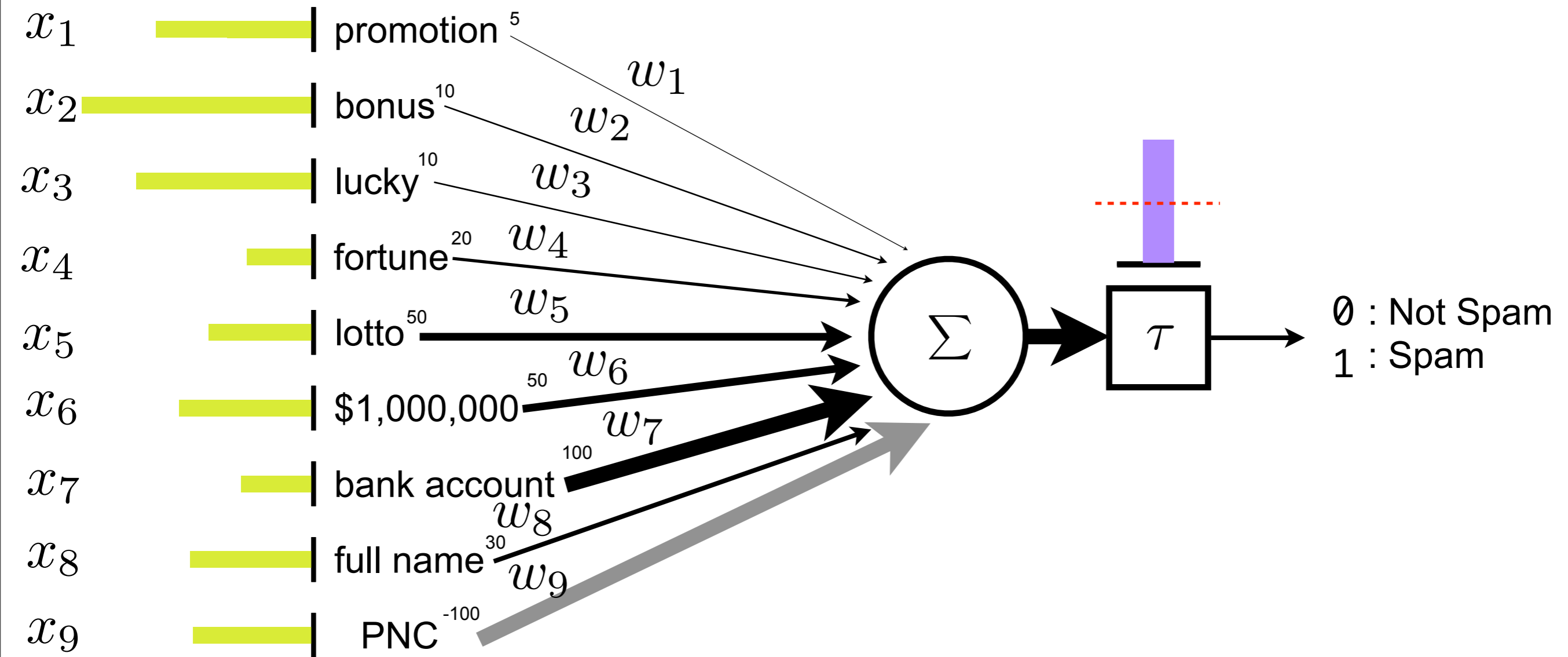

CLASSIFICATION

$$w_1x_1 + w_2x_2 + \cdots + w_nx_n \geq \tau$$

$$w_1x_1 + w_2x_2 + \cdots + w_nx_n \geq -w_0$$

$$\begin{aligned} \mathbf{x} &= \begin{bmatrix} x_1 \\ x_2 \\ \vdots \\ x_P \end{bmatrix} & \mathbf{w} &= \begin{bmatrix} w_1 \\ w_2 \\ \vdots \\ w_P \end{bmatrix} \\ \mathbf{w}^T \mathbf{x} &= \begin{bmatrix} w_1 & w_2 & \cdots & w_P \end{bmatrix} \begin{bmatrix} x_1 \\ x_2 \\ \vdots \\ x_P \end{bmatrix} \\ &= w_1x_1 + w_2x_2 + \cdots + w_nx_n \geq -w_0 \end{aligned}$$

$$\mathbf{w}^T \mathbf{x} + w_0 \geq 0$$

LINEAR CLASSIFIER

$$\mathbf{w}^T \mathbf{x} + w_0 \geq 0$$

$$w_1 x_1 + w_2 x_2 + \hat{w}_0 \geq 0$$

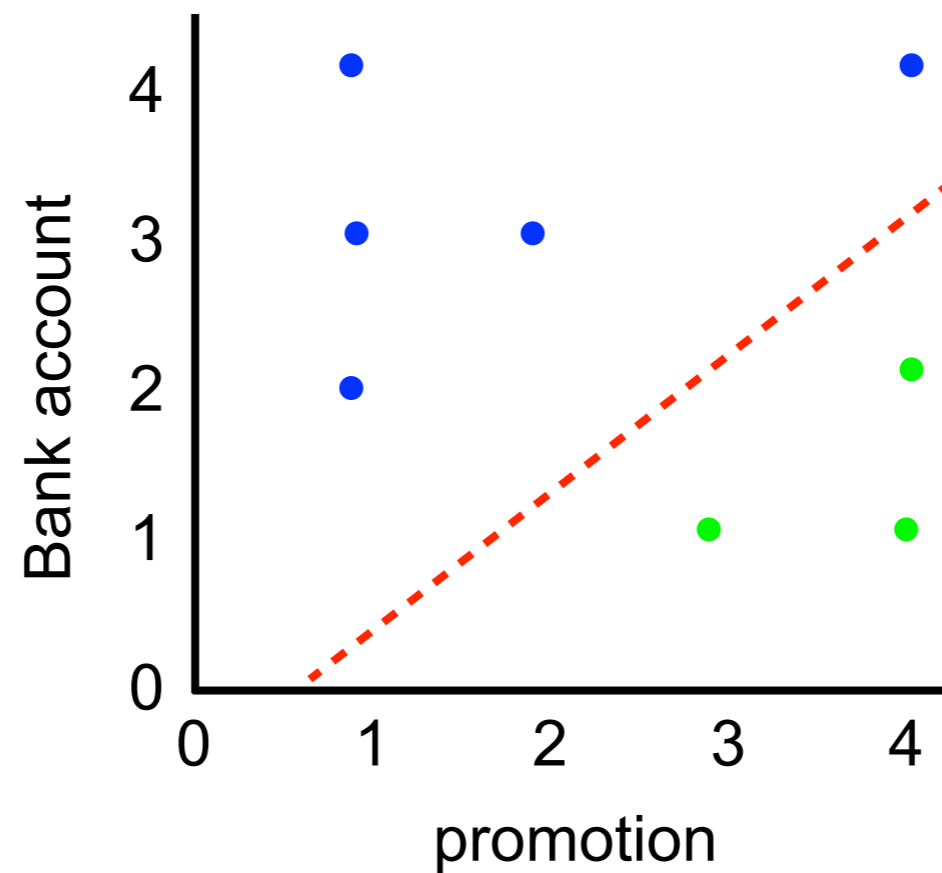

LEARNING

The image shows a screenshot of a Gmail spam folder in a Safari browser window. The browser's address bar shows the URL `http://mail.google.com/mail/?hl=en&tab=wm#spam`. The Gmail interface includes a search bar with `in:spam` entered, and buttons for `Search Mail` and `Search the Web`. The left sidebar shows the `Spam (482)` folder selected. The main content area displays a list of spam messages, with the `Not spam` button highlighted in a red box. The messages include various spammy titles and snippets, such as `devis panneaux solaires`, `Despina Brenna`, `Ashlea Michiko`, `uzixicuciq4546`, `Shamika Aracelis`, `Scarlett Shane`, `Term Life Insurance`, `Jerrie Estela`, `EmploymentCrossingNew:`, `joy johnson`, `ComTechService`, `Kitty Missy`, `Mrs Elizabeth Rose Jones`, `Elvira Josephina`, `Tatiana Natalya`, `Best Senior Care`, `me`, `Michal Ayako`, `uikaro3076`, `Sabrina Darlene`, `The Dubai Aquarium and L`, and `Cherri Petronila`.

Neuron

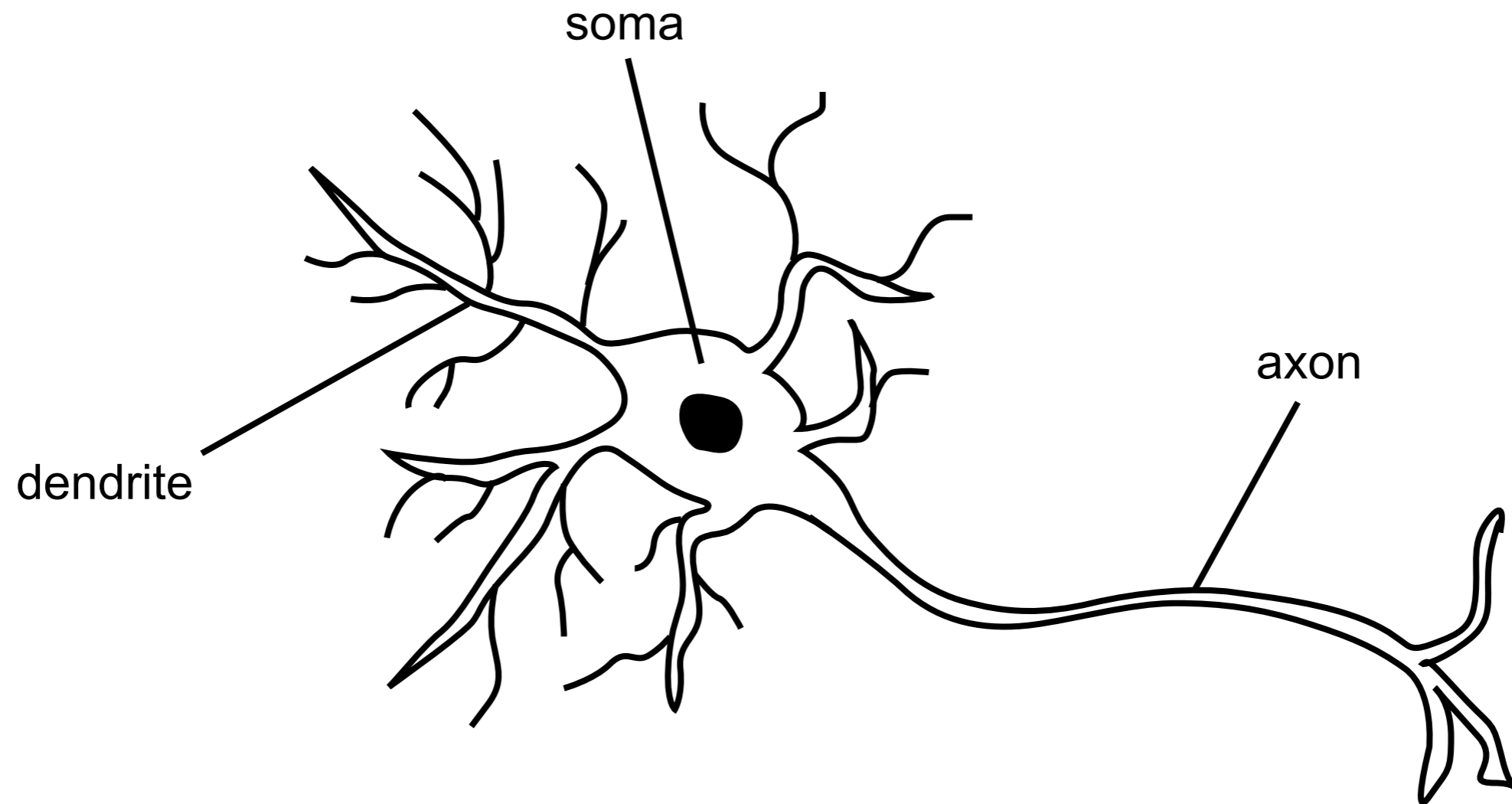

Action Potential

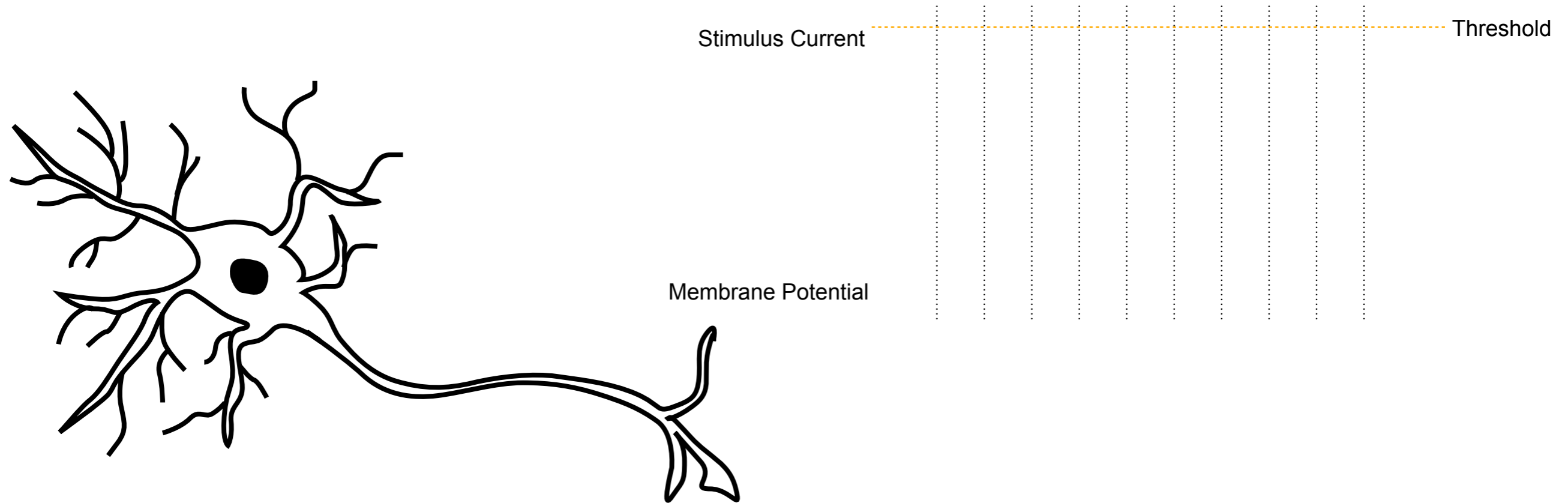

Synapse

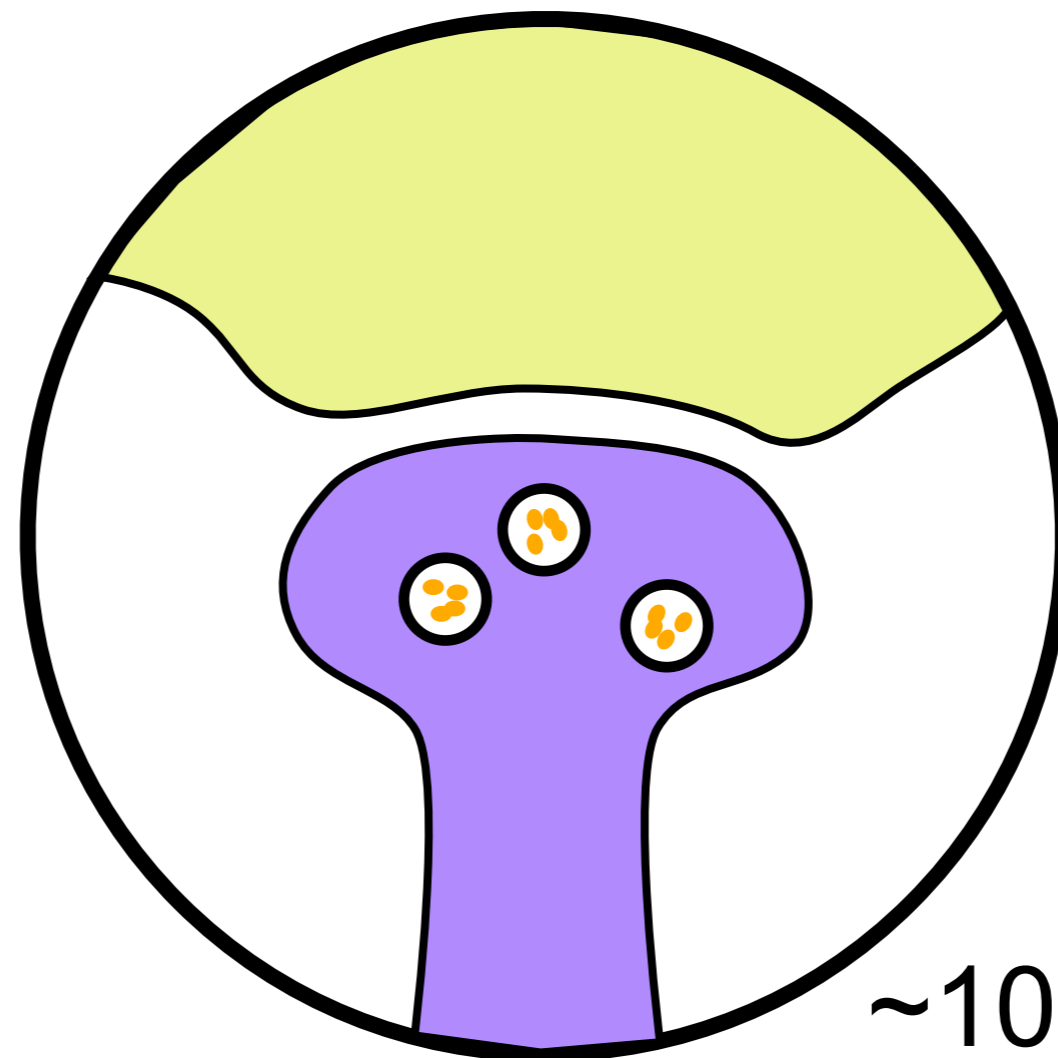
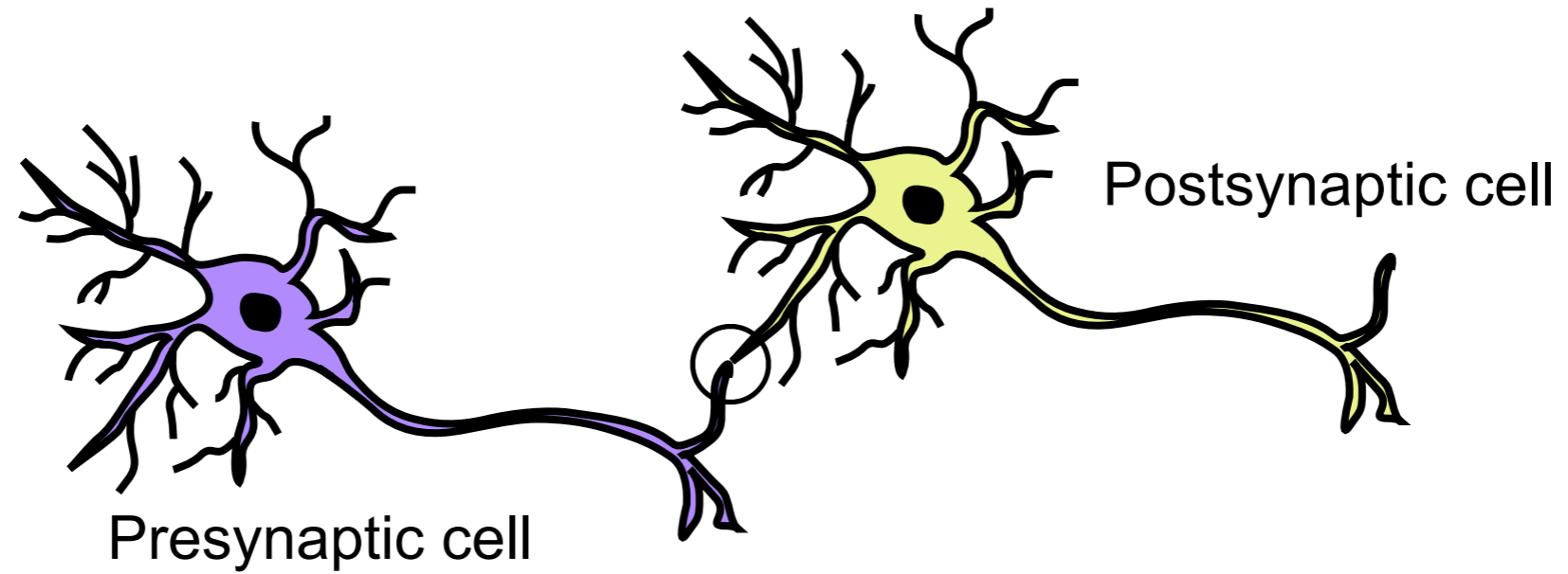

~10,000 synapses

Neuron

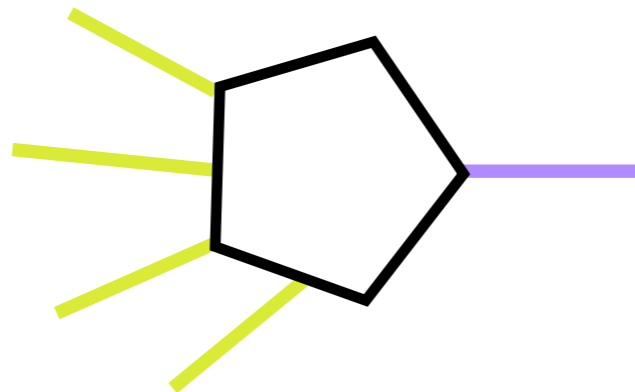
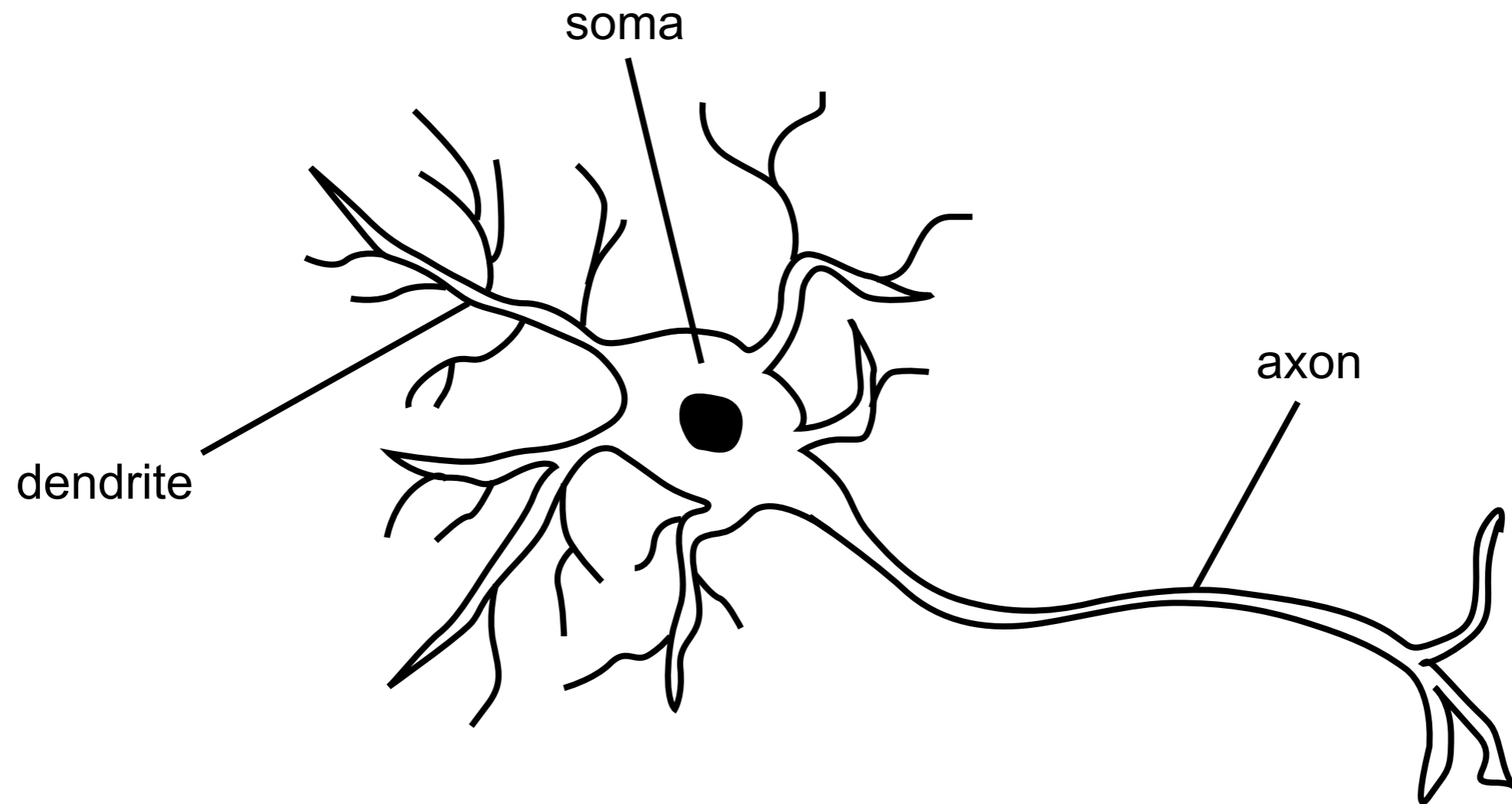

GRAPHICAL MODEL

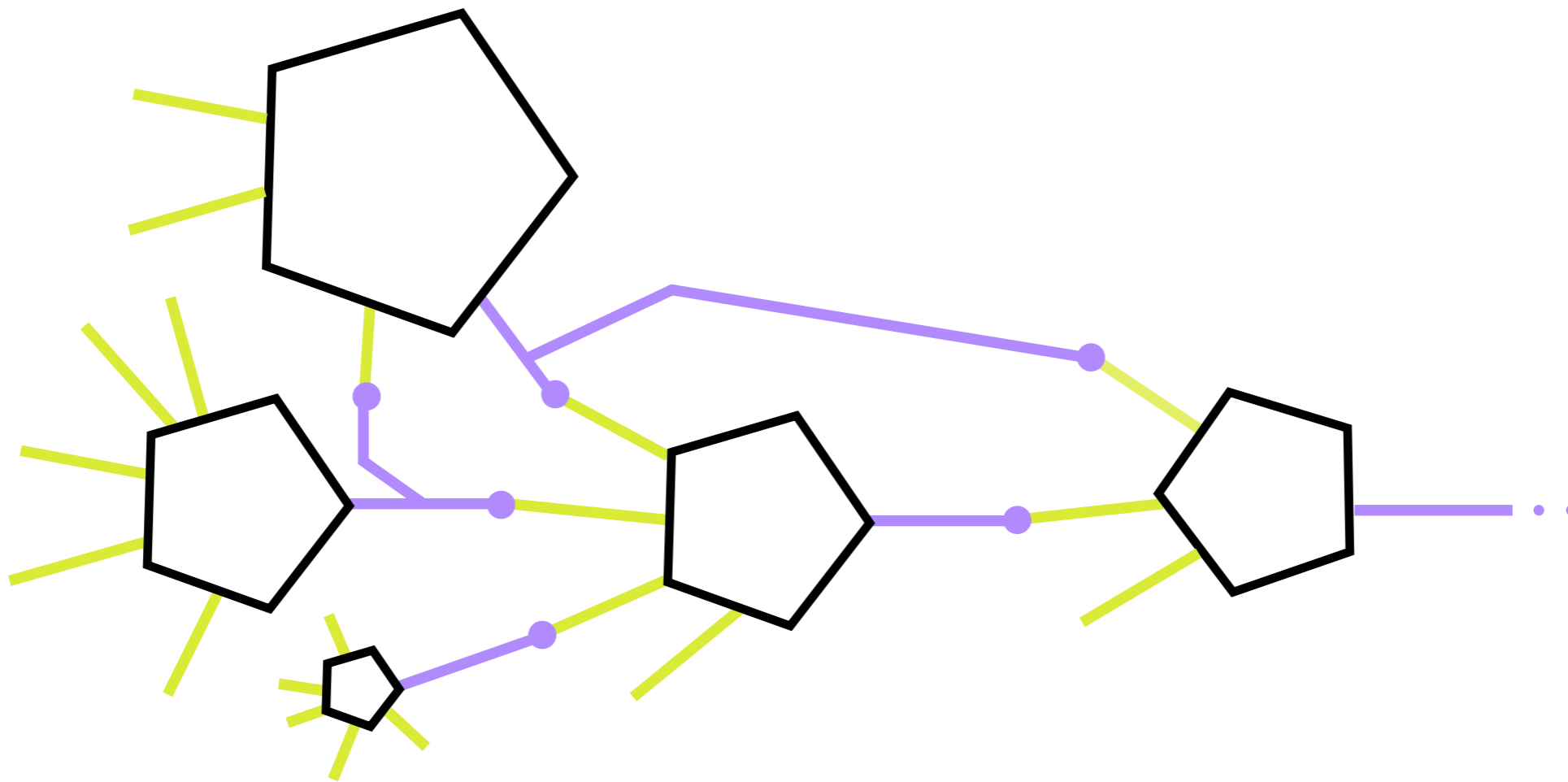

Model

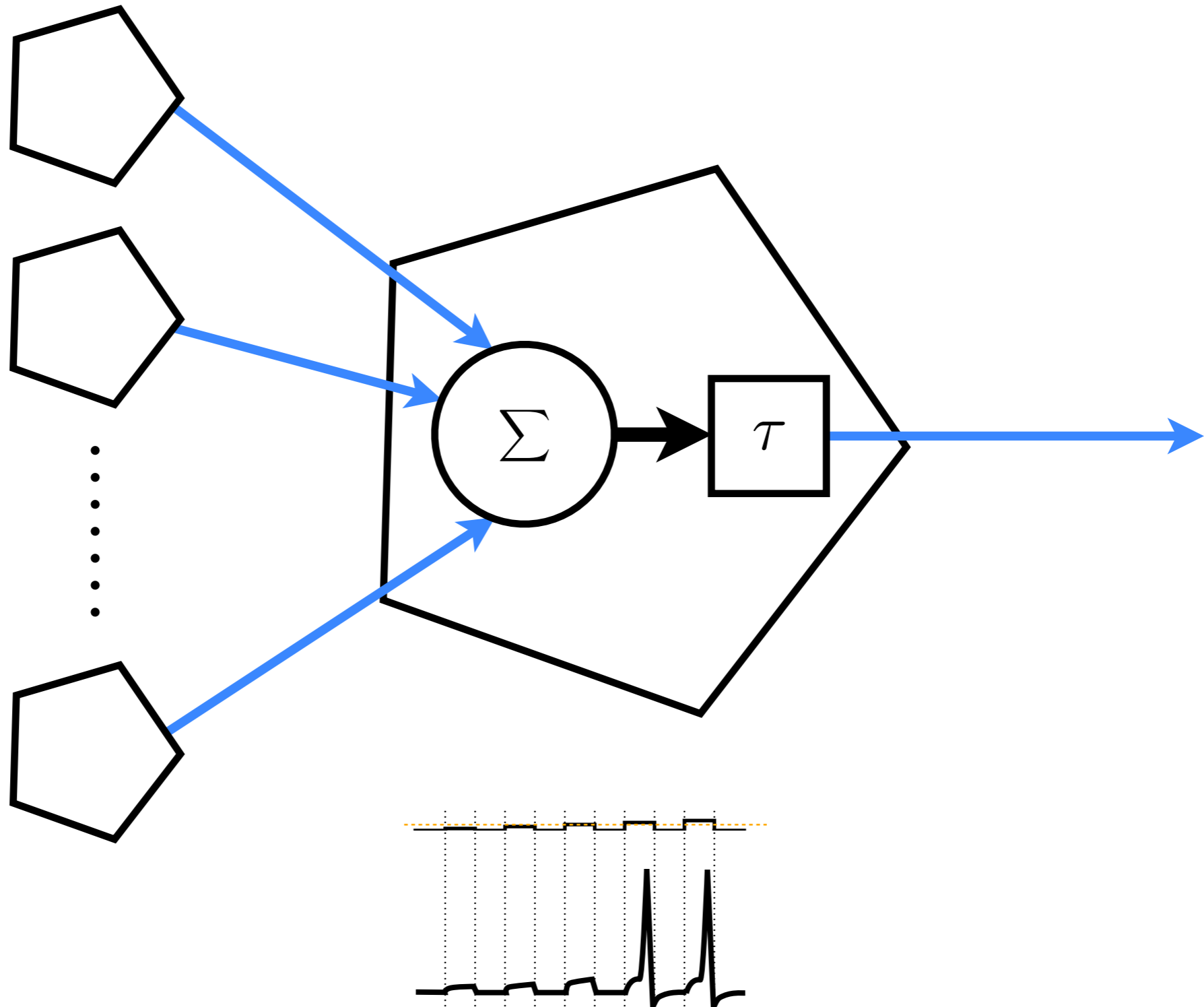

WEIGHTED SUM

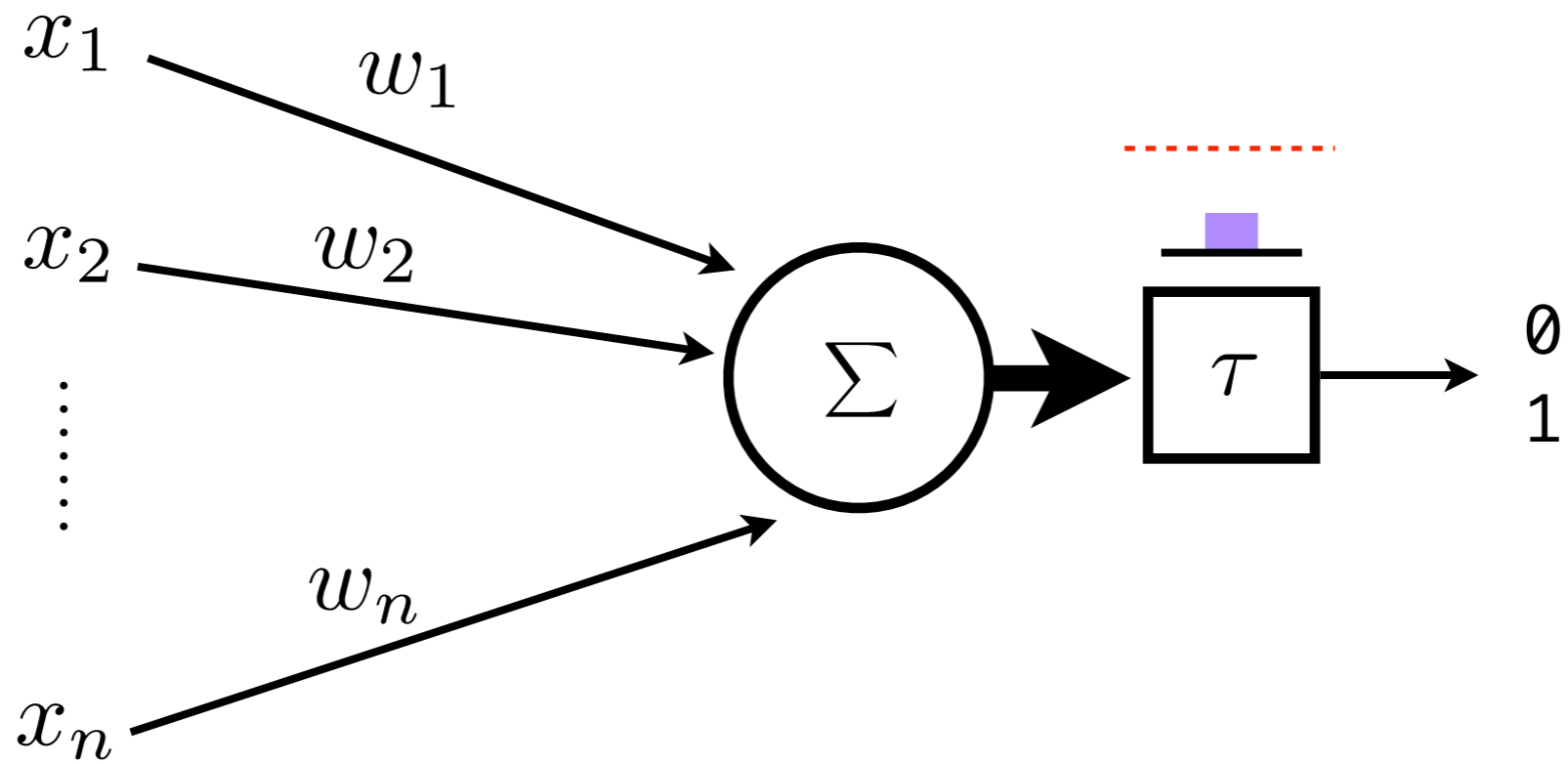

The Astonishing Hypothesis

“You, your joys and your sorrows, your memories and your ambitions, your sense of personal identity and free will, are in fact no more than the behaviour of a vast assembly of nerve cells and their associated molecules”

--- Francis Crick, 1994

Weak Stimulus

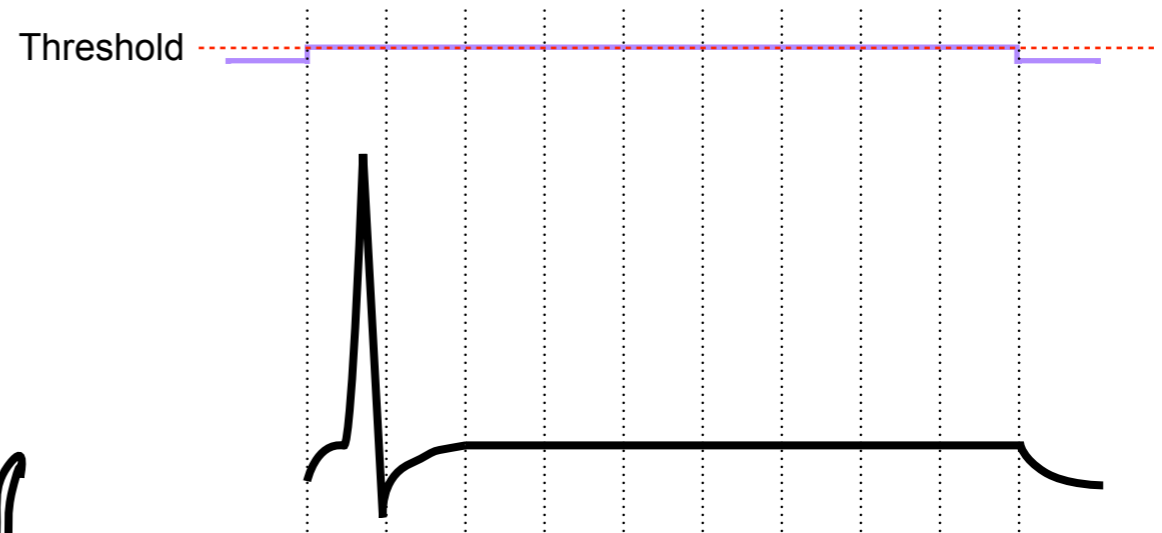
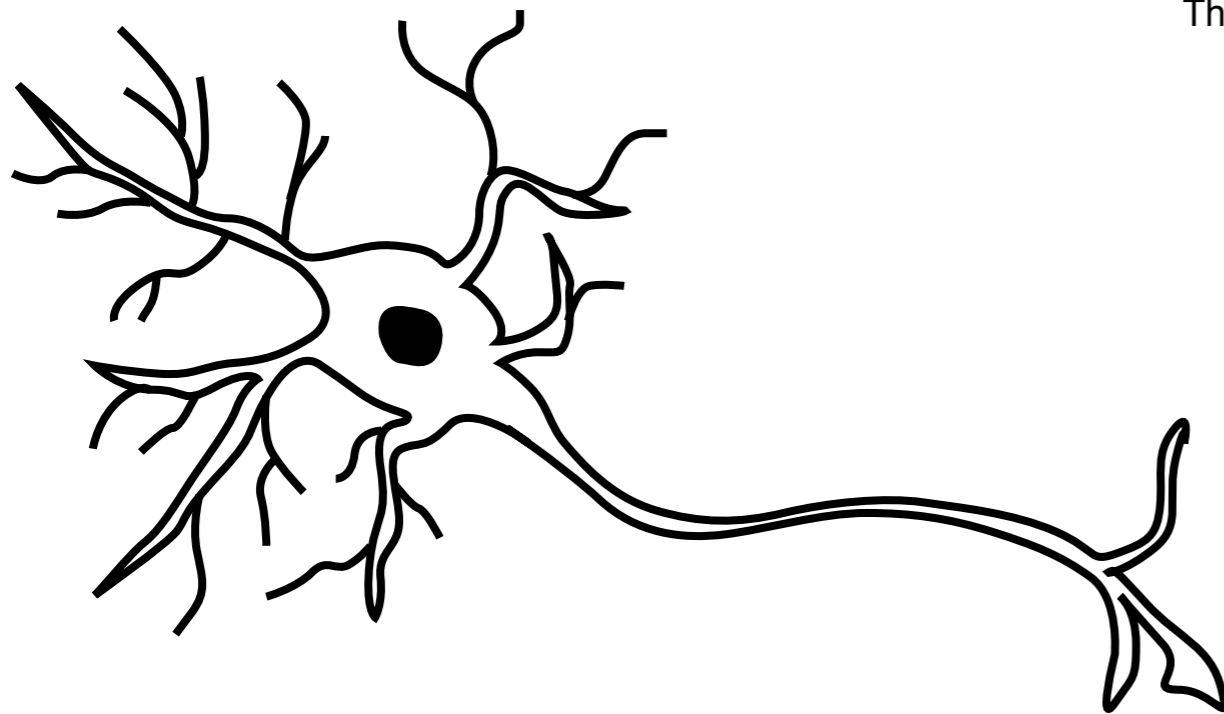

Medium Stimulus

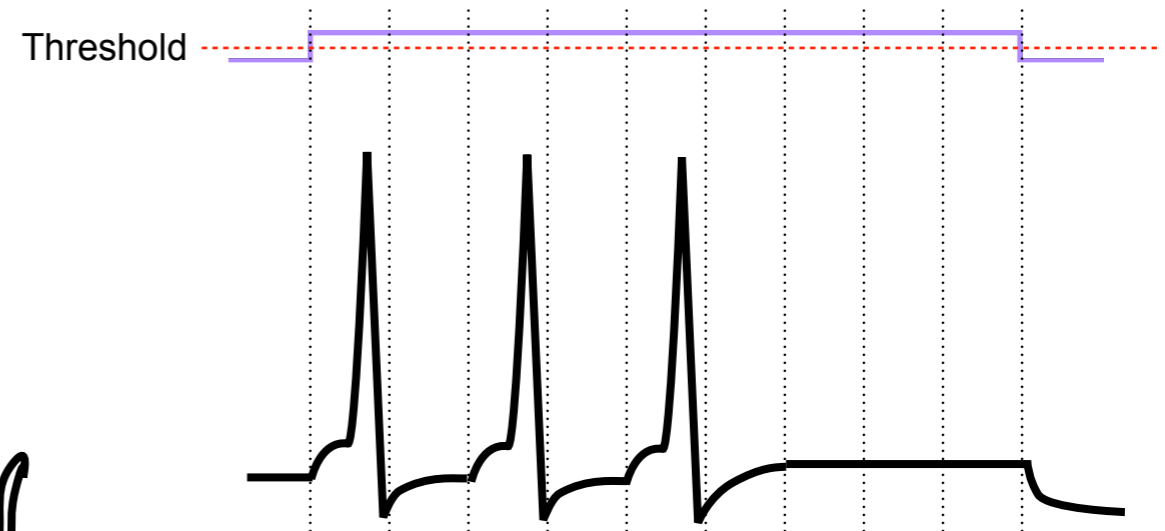
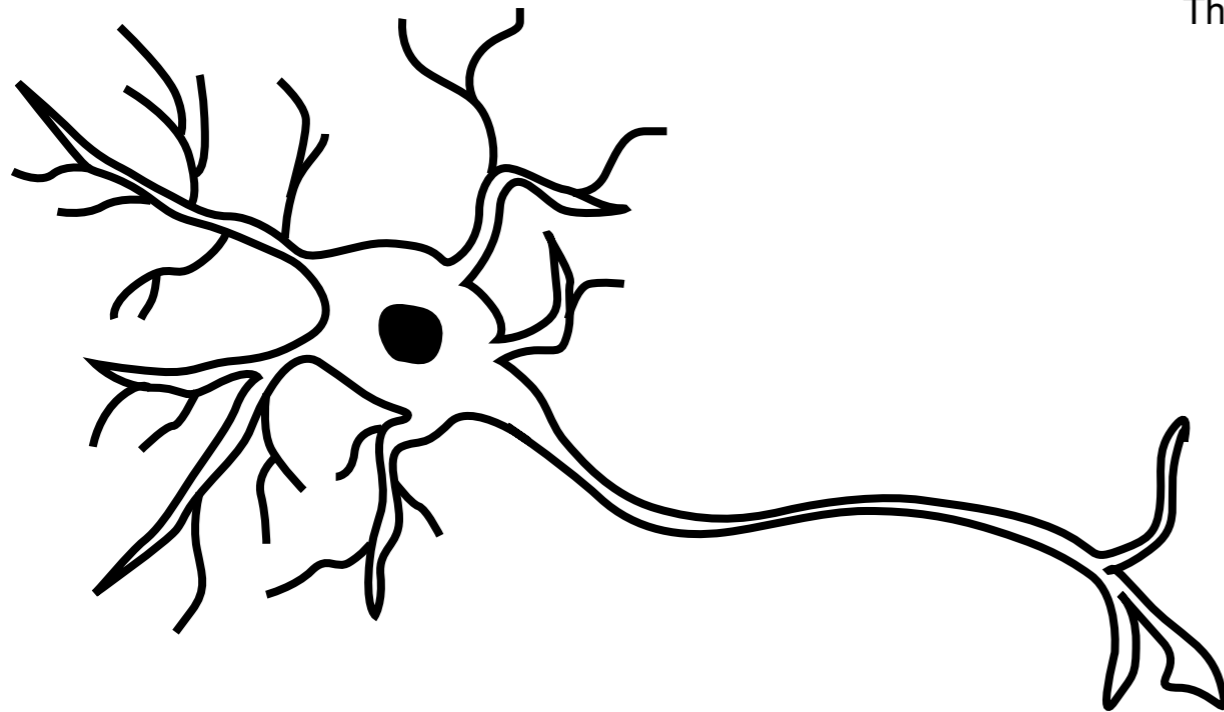

Strong Stimulus

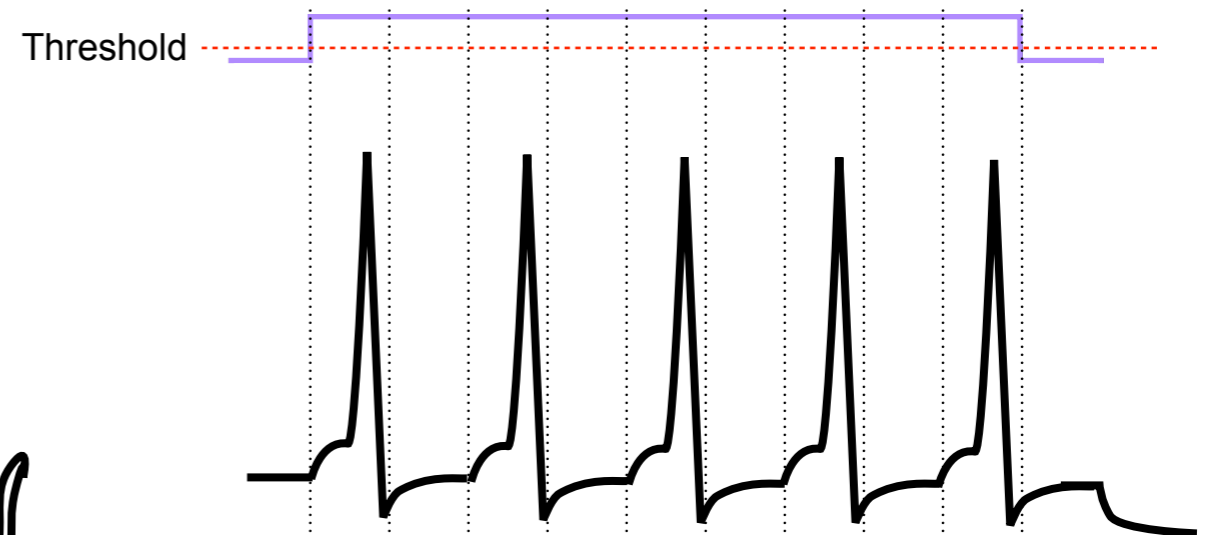
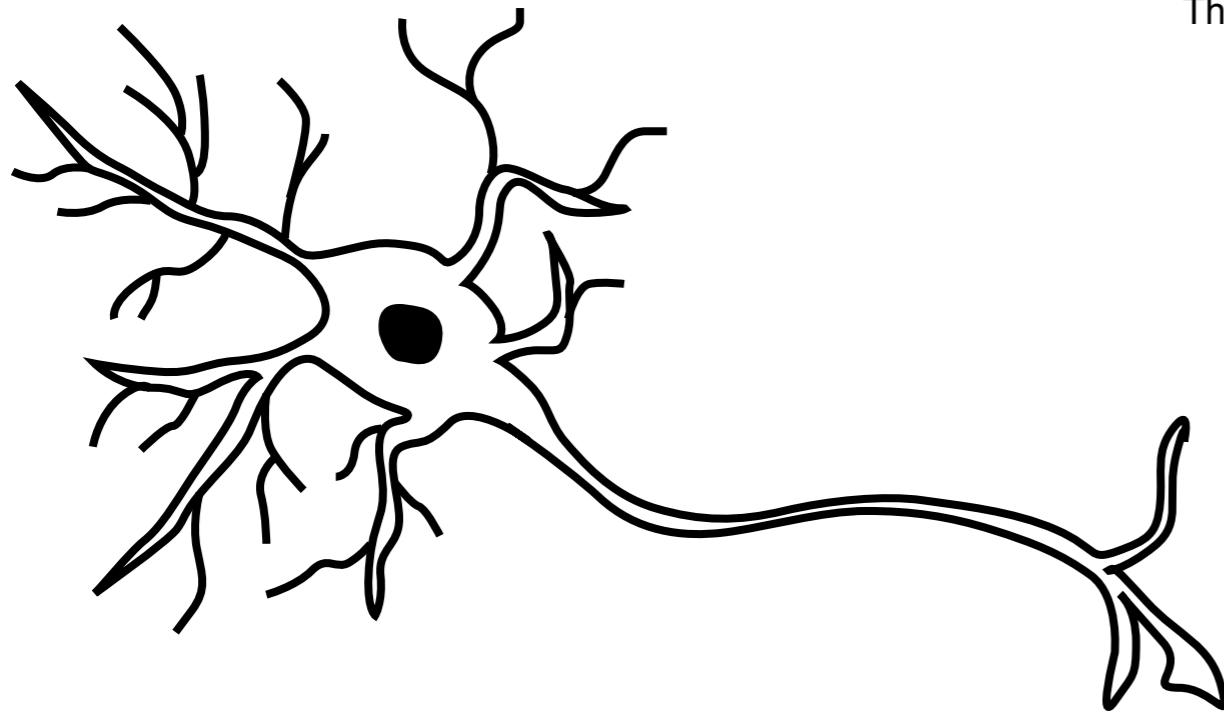

Information is in timing and frequency

Types of Neurons

- **Inter Neurons:** activated by other neurons
- **Sensory Neurons (Afferent Neurons):** activated by light, sound, smell, taste, or touch
- **Motor Neurons (Efferent Neurons):** axons connect to muscles

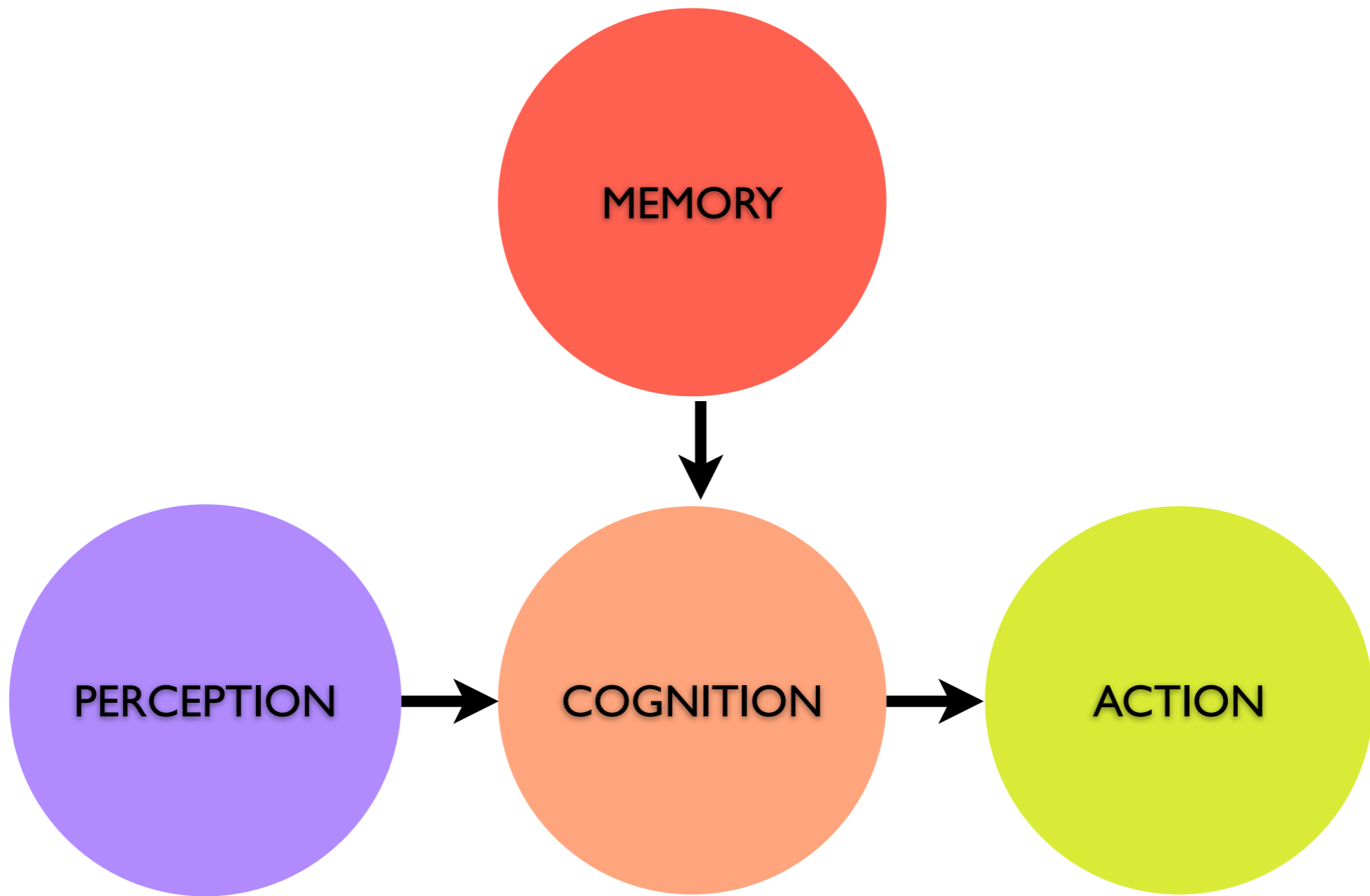

Central Nervous System

397

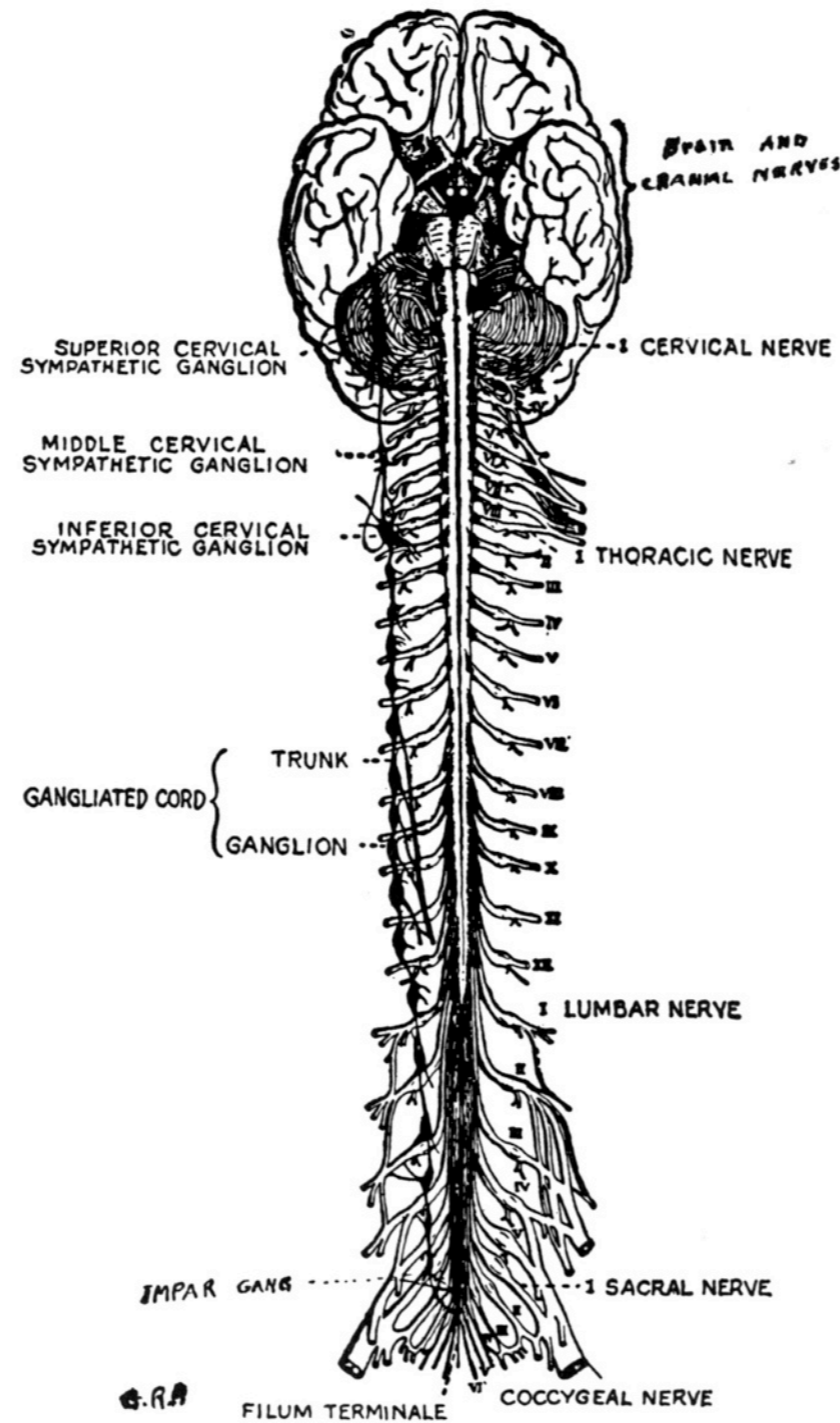

Figure Credit: Galen Price



Cerebrum

Cerebellum

Brain Stem

Figure Credit: Howard Florey Brain Research Institute

Triune Brain Theory

(Controversial)

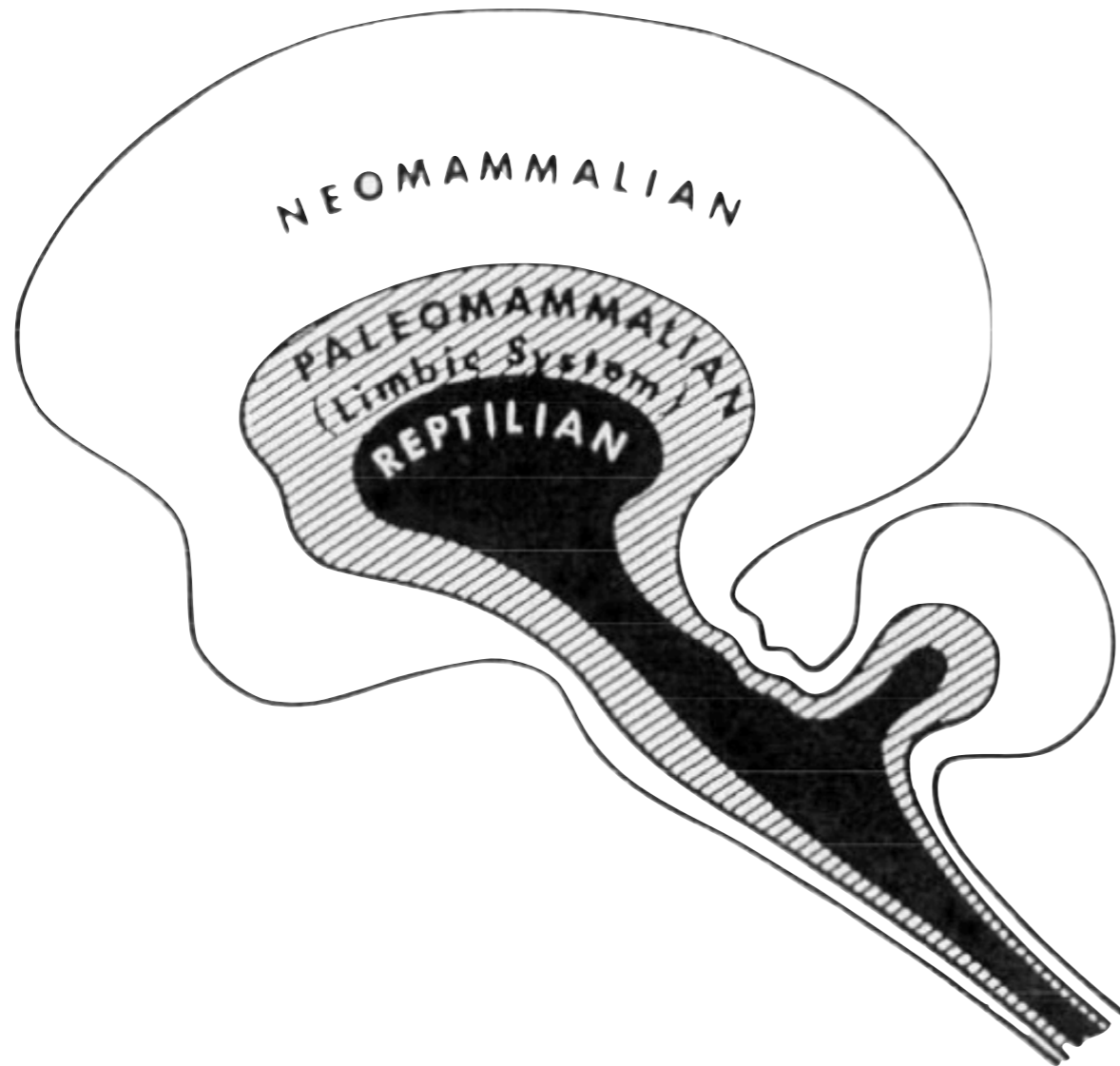

Figure Credit: Paul MacLean

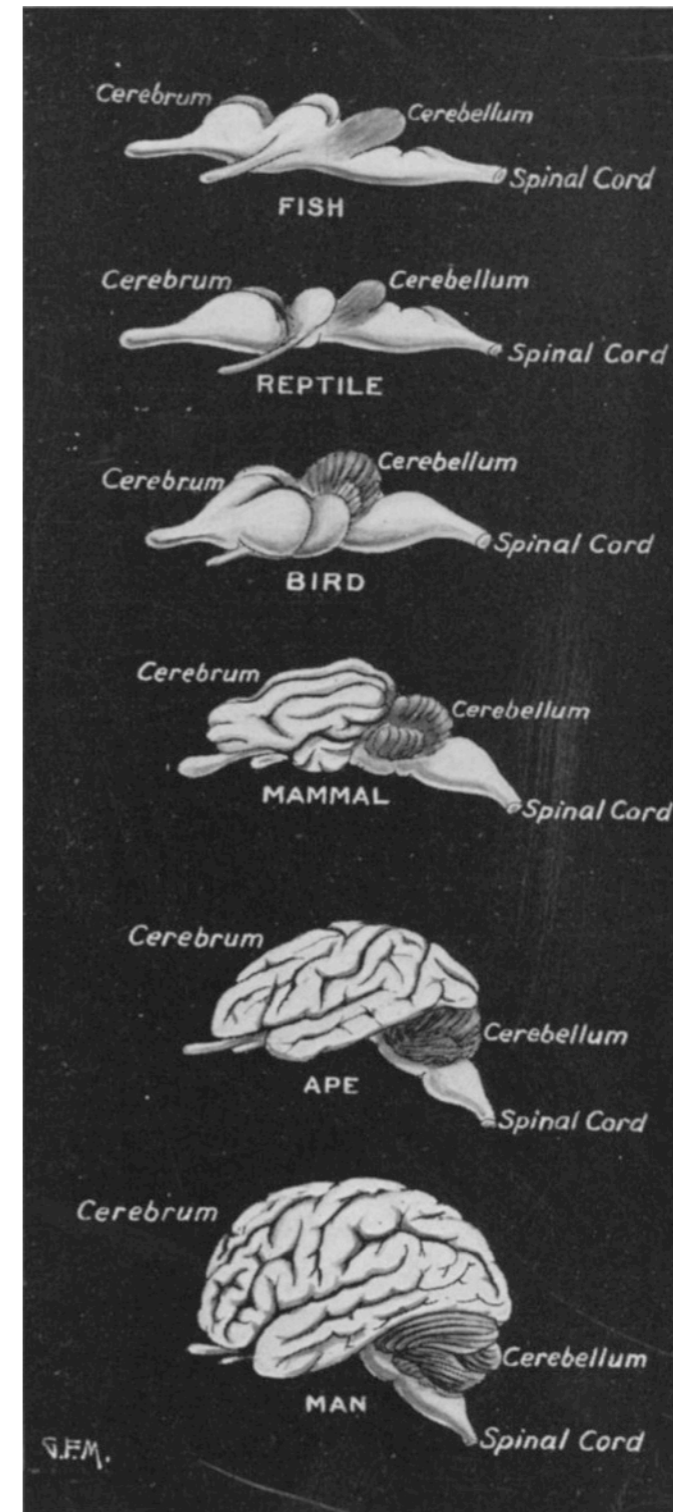
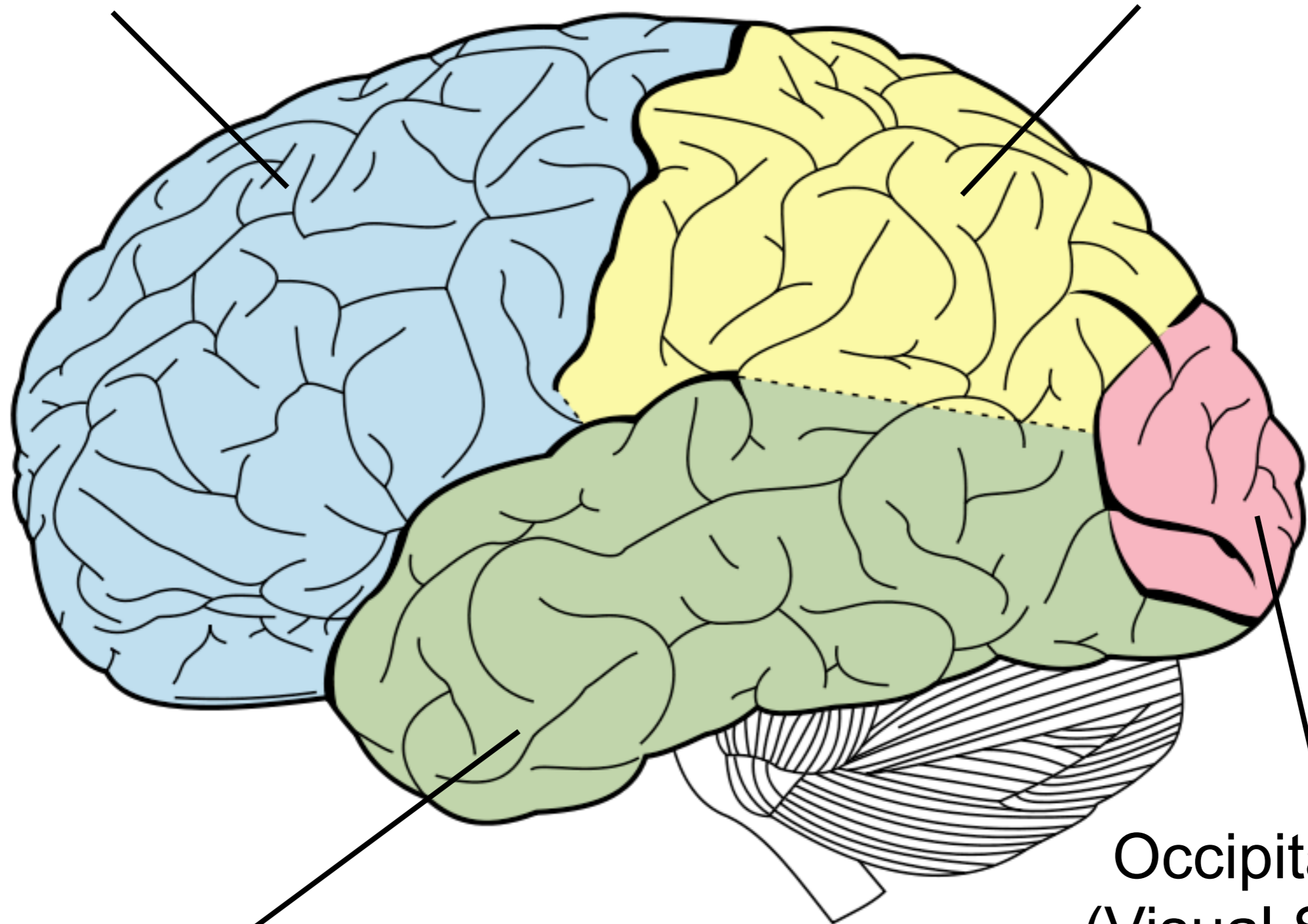

Figure Credit: J. Arthur Thomson

Frontal Lobe
(Executive)

Parietal Lobe
(Sensing, Spatial)



Temporal Lobe
(Audio Sensing, Memory)

Occipital Lobe
(Visual Sensing)

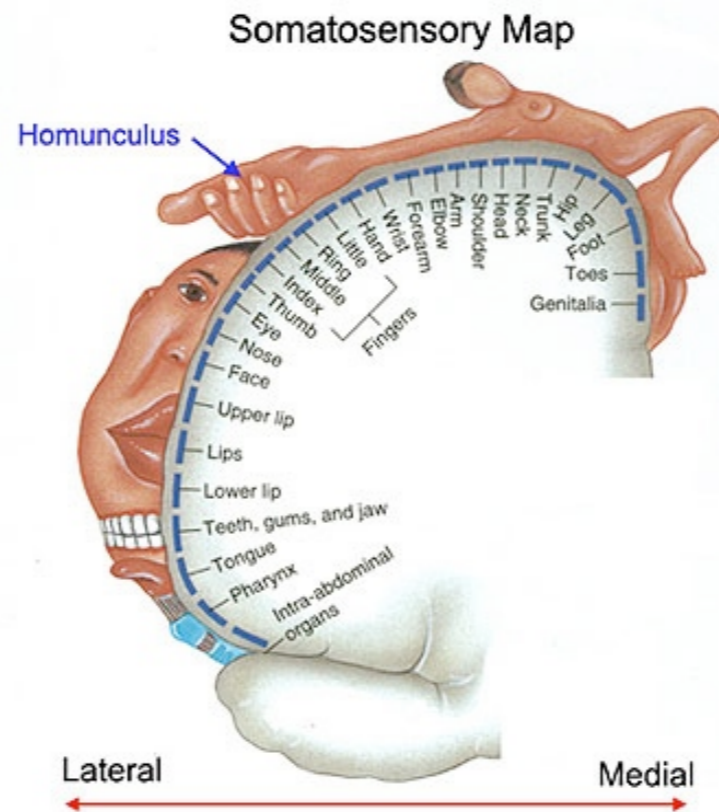
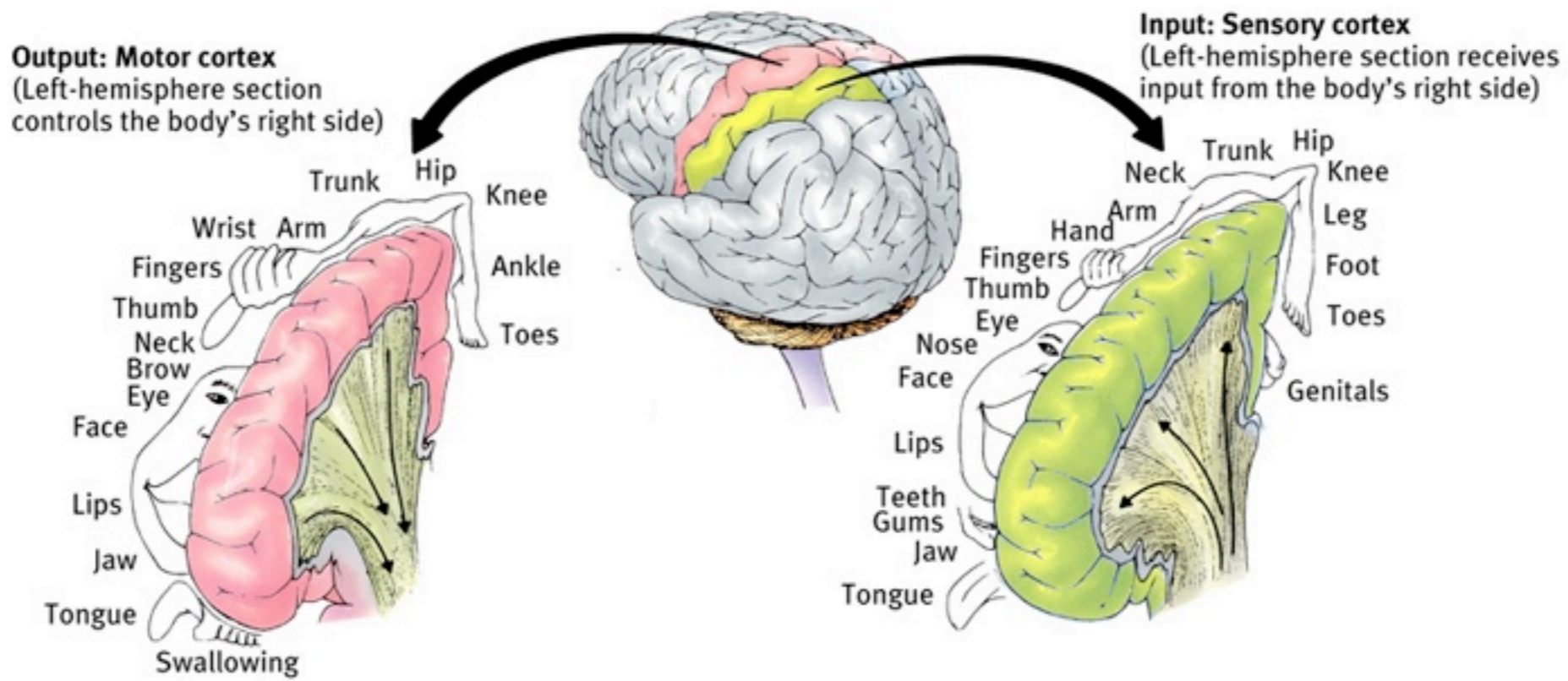
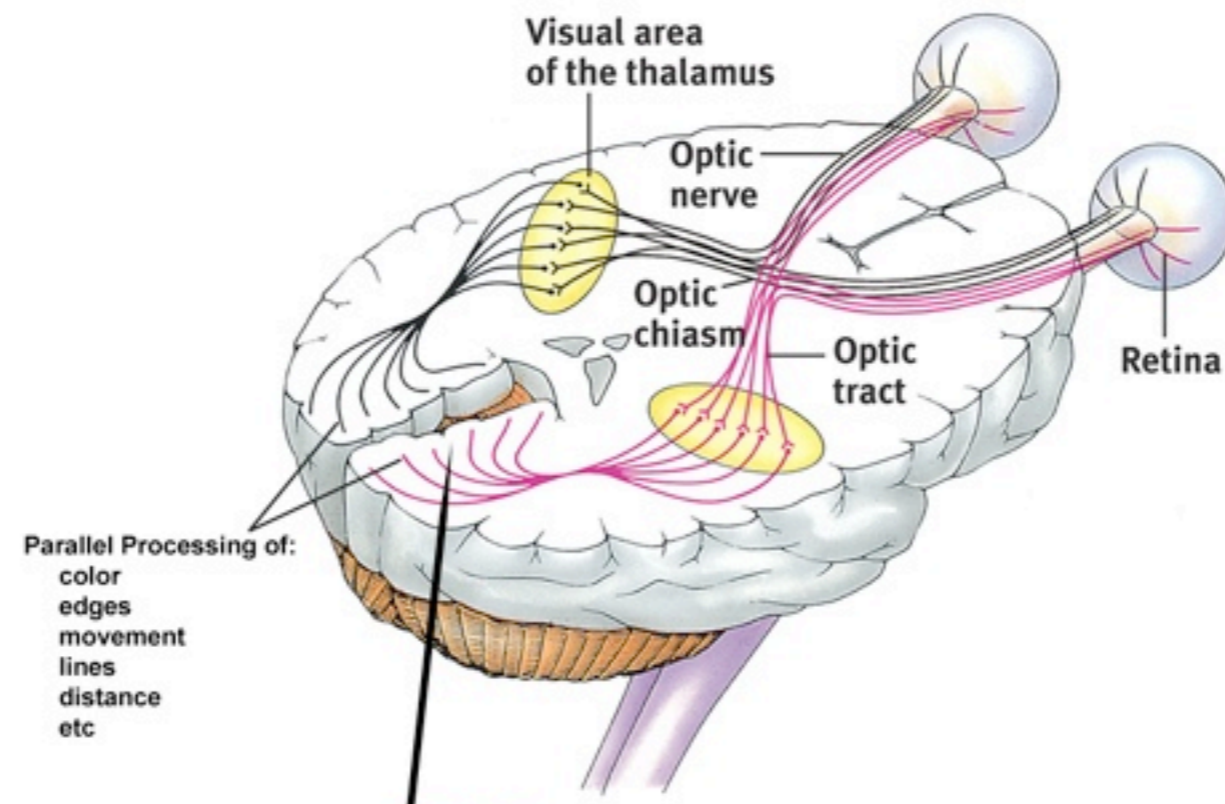

Figure Credit: E. Bruce Goldstein

Phantom Limbs



OCCIPITAL LOBE



Cerebral Hemispheres

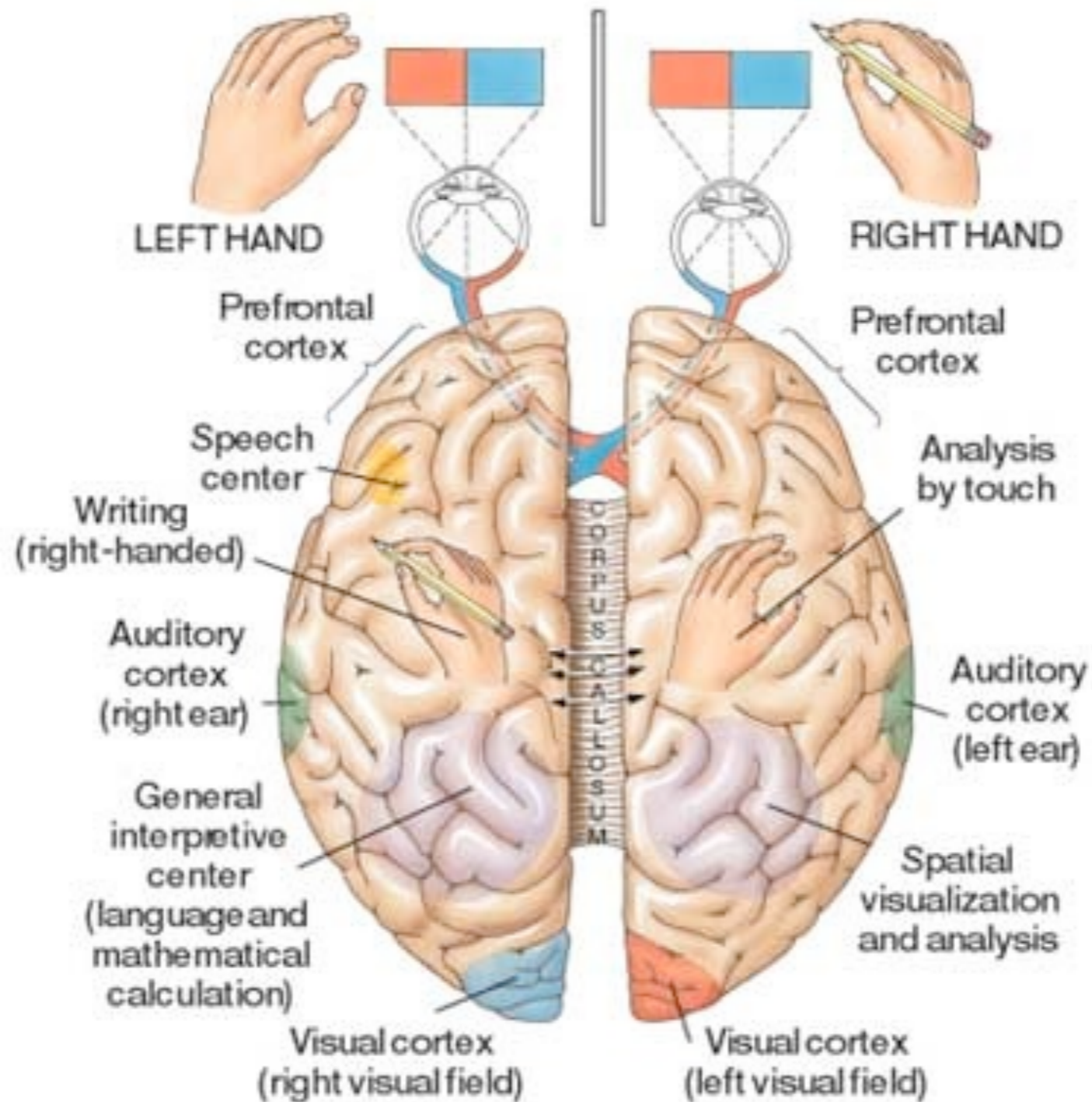

Figure Credit: Psychology: An Introduction, Charles G. Morris, Albert A. Maisto

Corpus Callosum



Laurence Kim Peek

Corpus Callosum

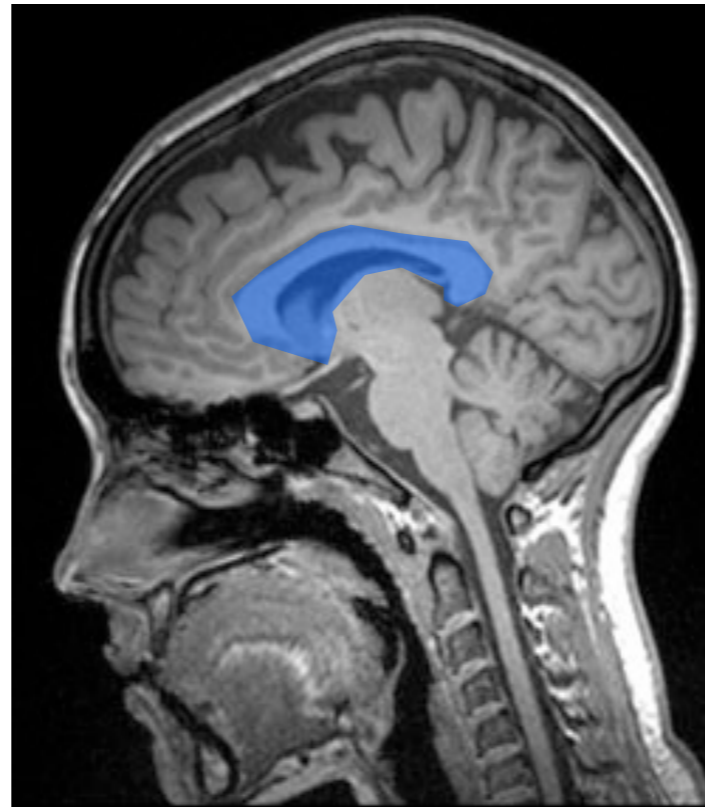

The “communication highway”
between the two halves of the brain

200 million fibers
processing several billion bits/sec

Figure Credit: Howard Florey Brain Research Institute

Corpus Callosum

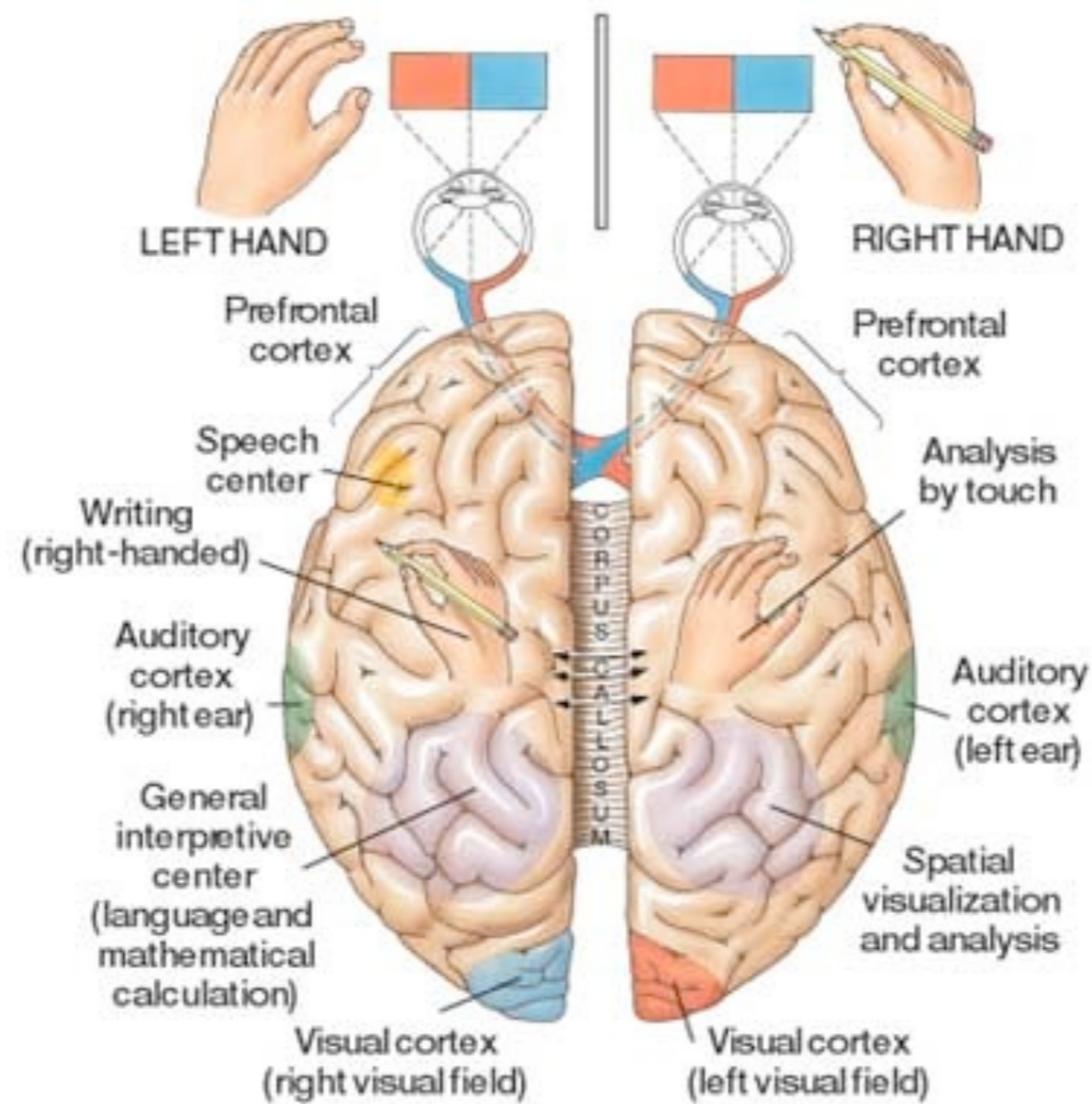

Split-brain Syndrome

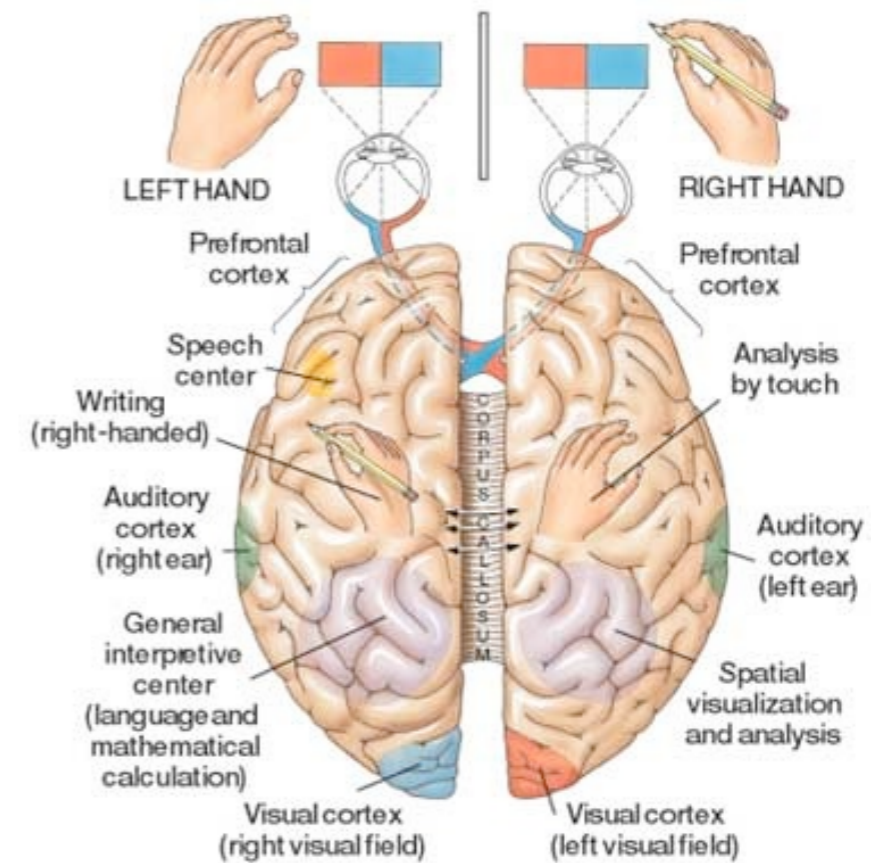
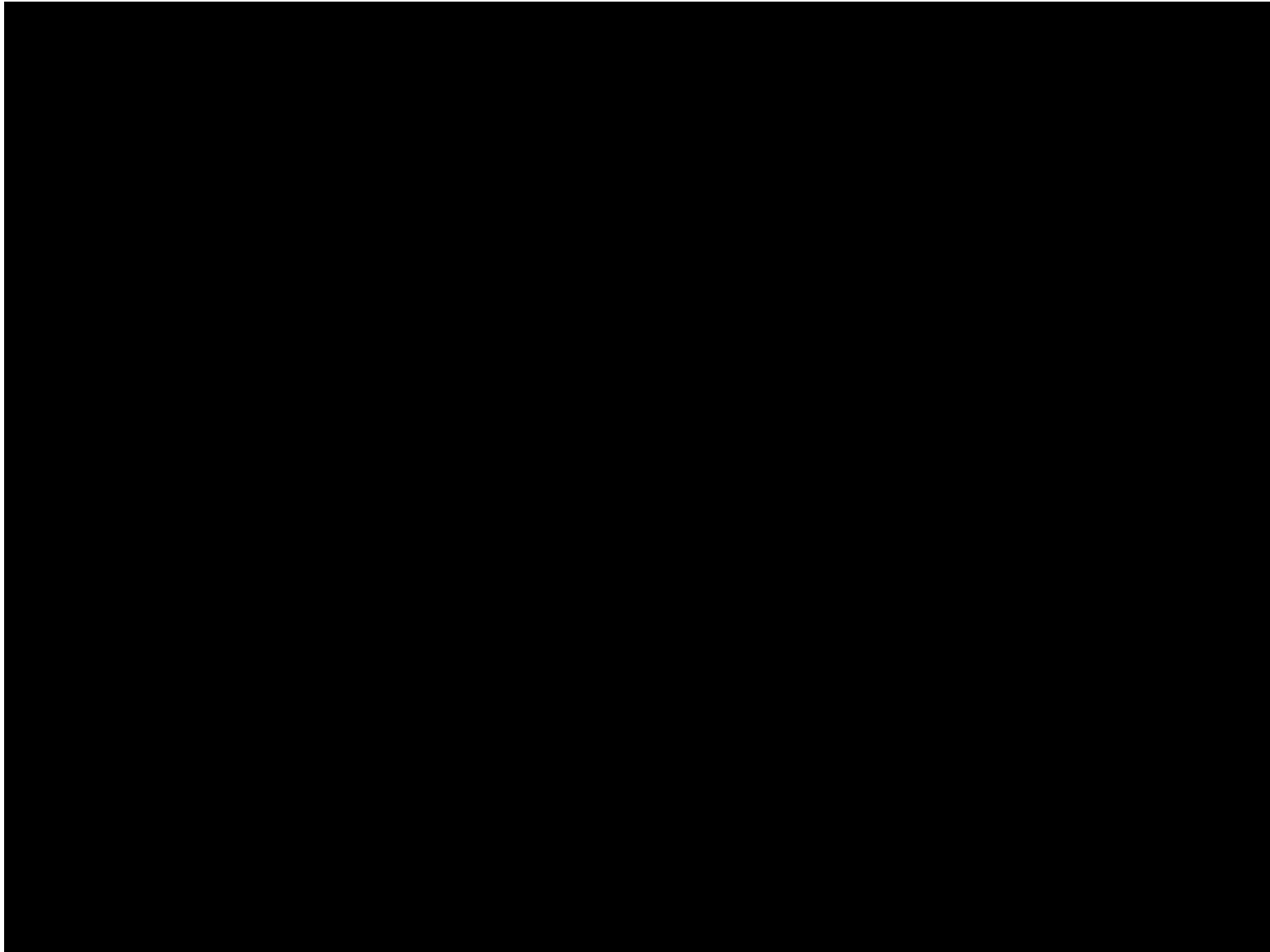

Fusiform Gyrus

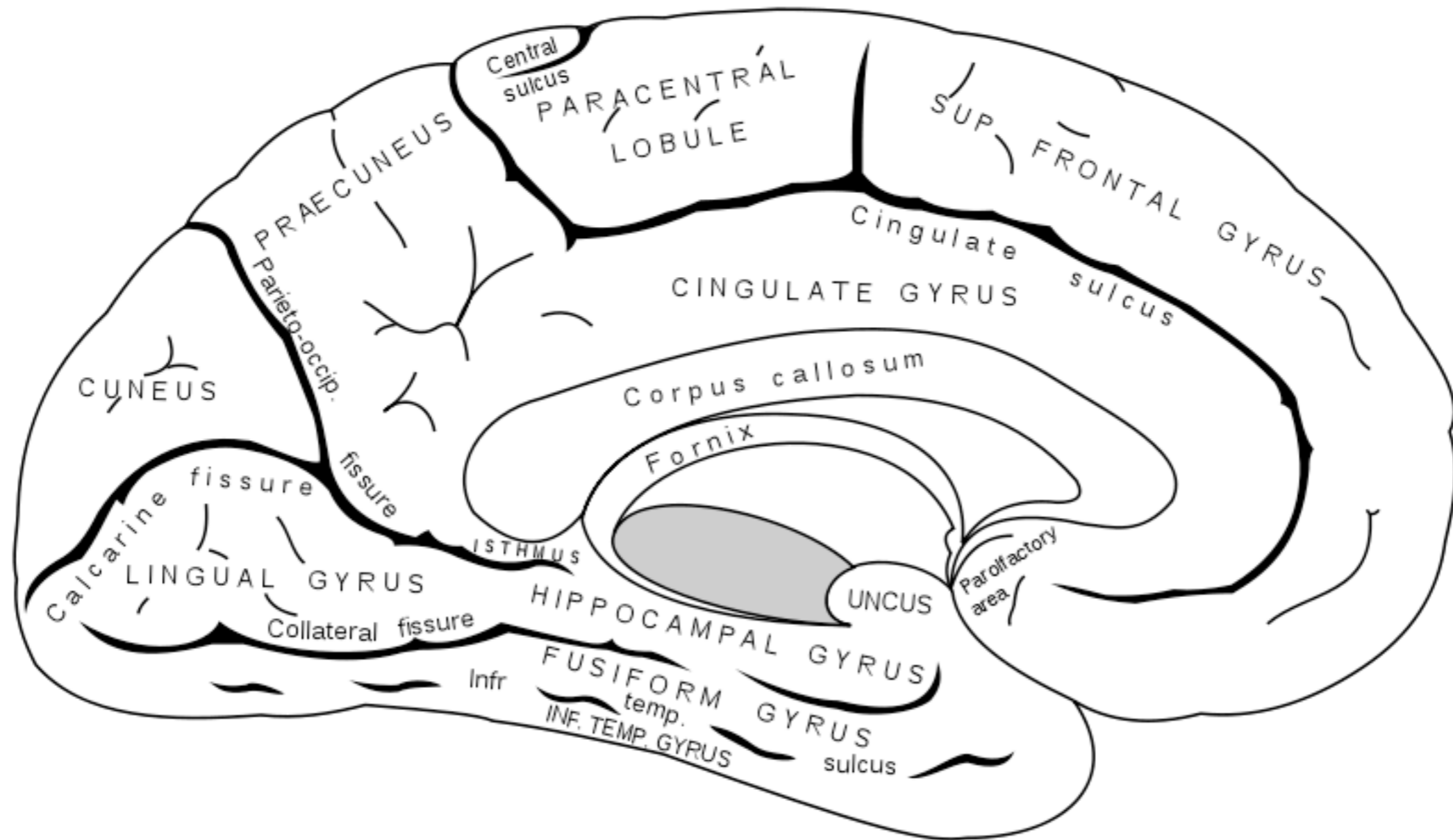

Prosopagnosia: Face Blindness

LIMBIC SYSTEM

- Forming memories
- Experiencing pleasure
- Emotion and motivation

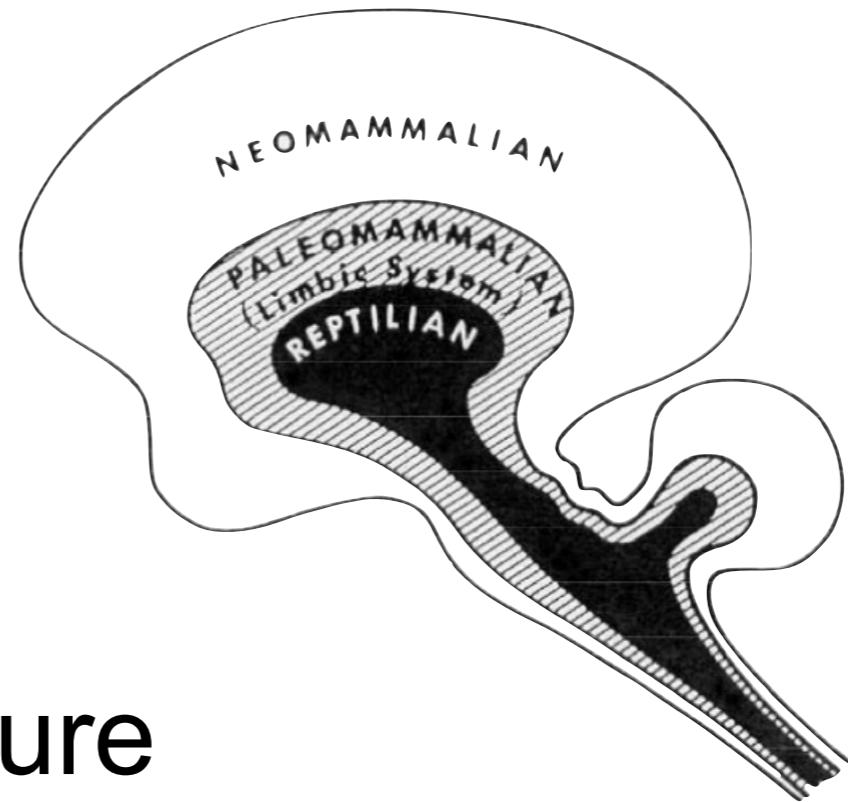

Amygdala

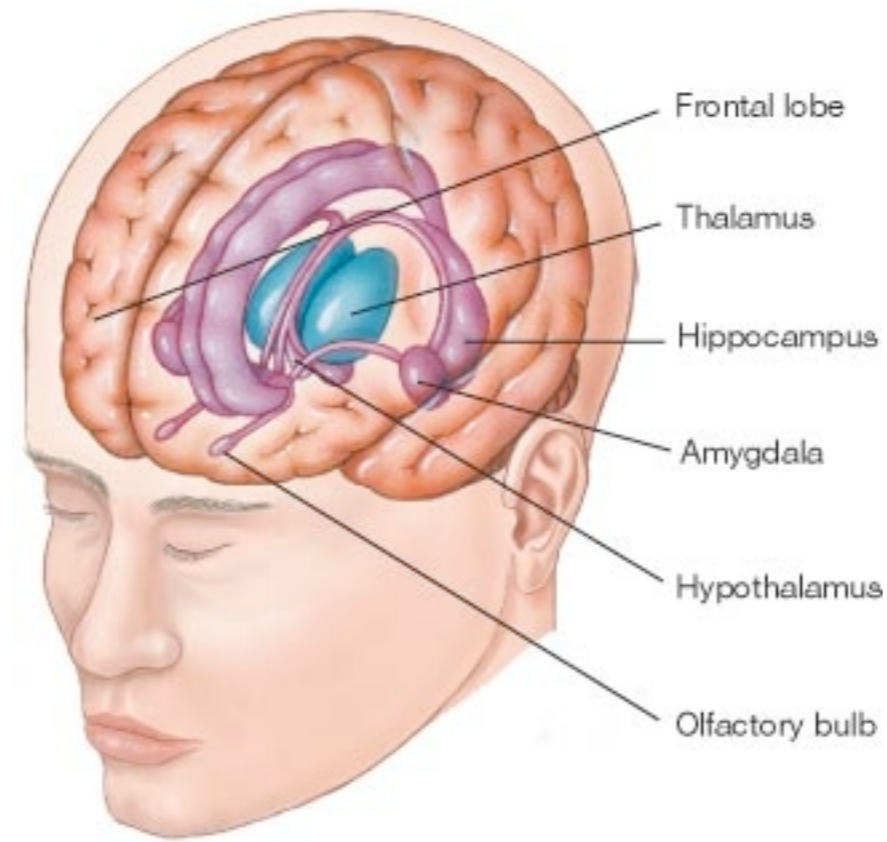

Emotion Processing and Memory

Capgras Syndrome

Figure Credit: Psychology: An Introduction, Charles G. Morris, Albert A. Maisto

Hippocampus



Henry Gustav Molaison (H.M.)

“Every day is alone in itself --- whatever enjoyment I’ve had and whatever sorrow I’ve had.”

Memory

Nondeclarative
(Implicit)

Declarative
(Explicit)

Nonassociative
Learning

Simple
Classical
Conditioning

Priming

Skills
and
Habits

Facts
(Semantic)

Events
(Episodic)

Other brain memory
systems

Medial Temporal
Lobe

Figure Credit: Squire and Zola-morgan, Science, 1991

CEREBELLUM

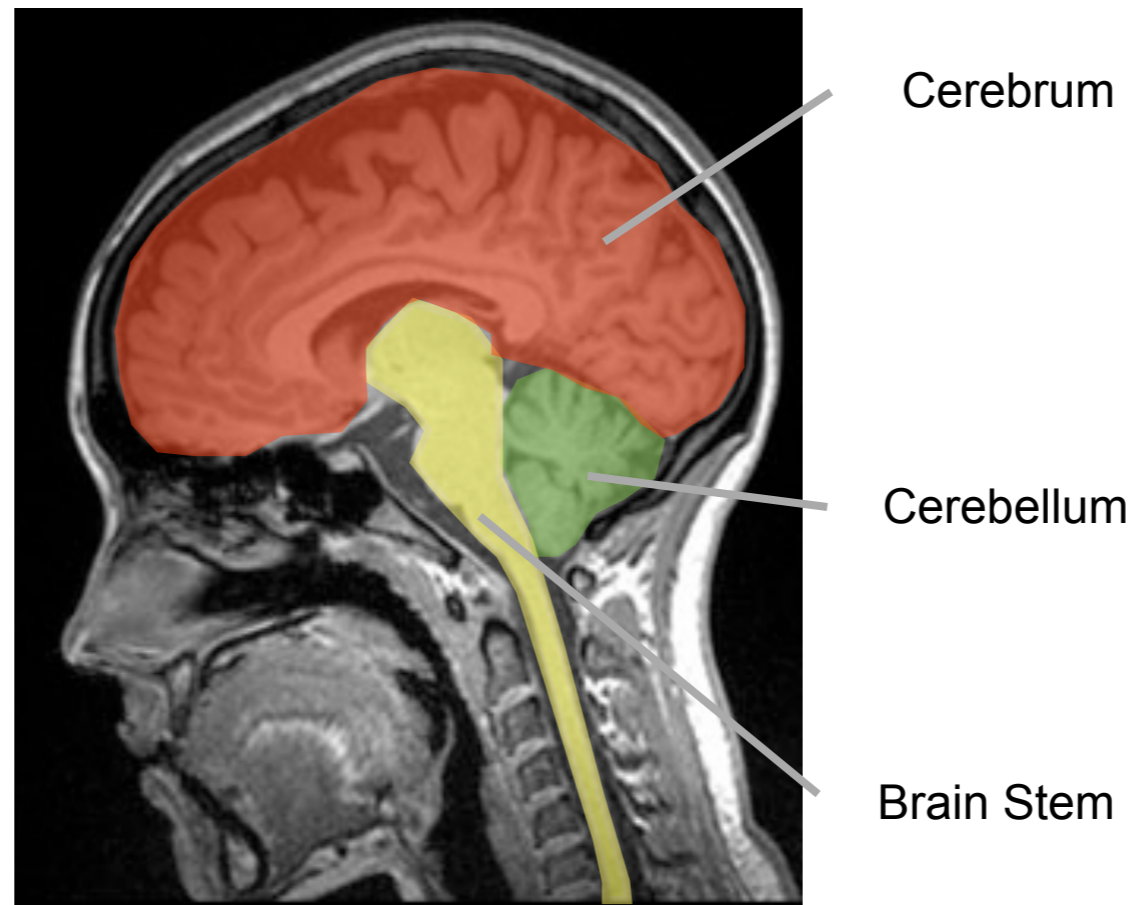

Basic Motor Function

BRAIN STEM

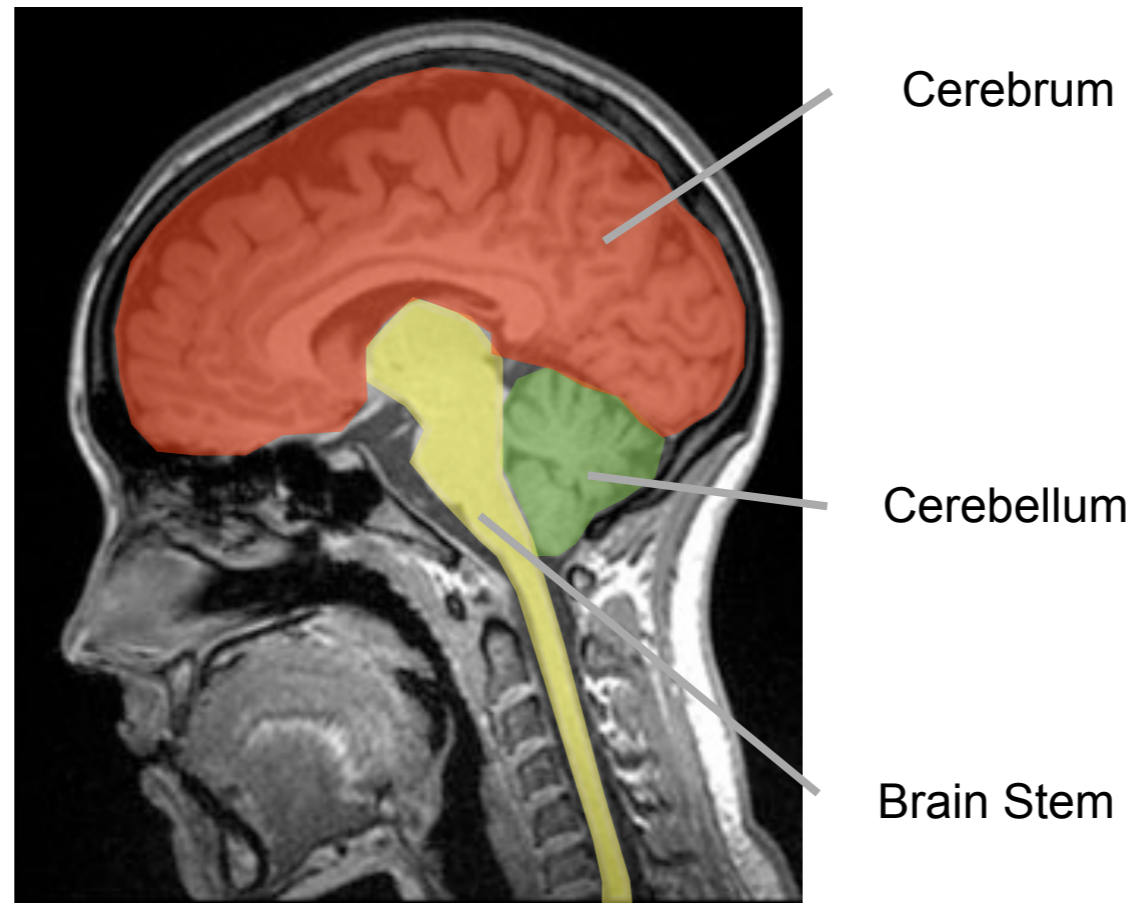

- Information conduit (cranial nerves)
- Regulation of critical brain function
 - Cardiovascular system
 - Respiratory system
 - Pain sensation
- *Grand Mal* Epilepsy

Center for Neural Basis of Cognition (CMU-Pitt)
Center for Cognitive Brain Imaging (CMU)

REVIEW

- Propositional Logic
- Introduction to Linear Classification
- Introduction to Neural Networks
- Overview of brain functions

Paper Reading Assignment

- 5% of overall grade
- Lightning session on October 21st
 - 1.5 minute overview of paper
 - Criteria for grading:
 - Algorithmic Explanation: Input, Output, Process (~1 minute)
 - Why is this paper interesting: application or elegance (~15 sec)
 - How can I improve this? (~15 sec)
 - How interesting is the paper
- Based on the content of your selection we will assign a reading mentor who can discuss the paper with you

Paper Reading Assignment

1. Association for the Advancement of Artificial Intelligence (AAAI)
 - <http://www.aaai.org> [AAAI 2010]
2. International Joint Conference on Artificial Intelligence (IJCAI)
 - <http://ijcai.org/> [IJCAI 2009]
3. Neural Information Processing Systems (NIPS)
 - <http://nips.cc/> [NIPS 2010]
4. Conference on Computer Vision and Pattern Recognition (CVPR)
 - <http://cvl.umiacs.umd.edu/conferences/cvpr2010/> [CVPR 2010]
5. International Conference on Robotics and Automation (ICRA)
 - <http://icra2010.grasp.upenn.edu/> [ICRA 2010]

Paper Reading Assignment

- Select a paper from one of these conferences by September 23rd
 - Email: [yaser \[at\] cs.cmu.edu](mailto:yaser[at]cs.cmu.edu)
 - Make sure the title has the words in the Subject: “AI 15-381”

SPAM

The screenshot shows a Gmail interface in a Safari browser window. The browser's address bar displays the URL `http://mail.google.com/mail/?hl=en&tab=wm#spam`. The page title is "Gmail - Spam (482) - subail@gmail.com". The Gmail logo is visible in the top left corner. A yellow banner at the top of the main content area is titled "Create a Filter". Below this banner, there is a section for "Choose search criteria" with several input fields: "From:", "To:", "Subject:" (containing "AI 15-381"), "Has the words:", "Doesn't have:", and a checkbox for "Has attachment". At the bottom of this section are buttons for "Cancel", "Test Search", and "Next Step »". Below the filter section, the main email list is visible. The list is titled "Spam Swiss Pie - Bake 45-55 minutes or until eggs are set". Above the list are action buttons: "Delete forever", "Not spam", "Move to", "Labels", "More actions", and "Refresh". A link says "Delete all spam messages now (messages that have been in Spam more than 30 days will be automatically deleted)". The email list contains several entries, many of which are redacted with black bars. Visible entries include: "devis panneaux solaires", "Despina Brenna", "Ashlea Michiko", "uzixicuciq4546", "Shamika Aracelis", "Scarlett Shane", "Term Life Insurance", "Jerrie Estela", "EmploymentCrossingNew:", "joy johnson", "ComTechService", "Kitty Missy", and "Mrs Elizabeth Rose Jones". A left sidebar shows navigation options like "Mail", "Contacts", "Tasks", "Compose mail", "Inbox", "Starred", "Sent Mail", "Drafts (129)", "Spam (482)", "[Gmail]Trash", "Personal", "Travel", "5 more", and "Yaser Sheikh".