

48-747 Shape Grammars

TERRAGNI 'S CASA GUILIANI FRIGERIA

A pioneer of the modern movement in Italy

A founding member of the fascist Gruppo 7 and a leading Italian Rationalist, Terragni fought to move architecture away from neo-classical and neo-baroque revivalism.

In 1926 he and other progressive members of Gruppo 7 issued the manifesto that made them the leaders in the fight against revivalism.

In a career that lasted only 13 years, Terragni created a small but remarkable group of designs; nearly all of them are in Como which was then the center of modern Italian architecture.

These works form the nucleus of the language of Italian rationalist or modernistic architecture. In his last designs, Terragni achieved a more distinctive Mediterranean character through the fusion of modern theory and tradition.

Giuseppe Terragni (b. Meda, Italy 1904; d. Como, Italy 1943)



Casa Giuliani Frigeria



Casa Giuliani Frigeria

circa 1943

Apartment building

Basement

Three floors

Penthouse

14 apartments

Eisenman spent 40 years studying Terragni and produced a book

Giuseppe Terragni: Transformations, Decompositions, Critiques

In 1971 tried to describe the building using rules of syntax and later in 1978 declared the enterprise hopeless.

casa guiliani frigeria

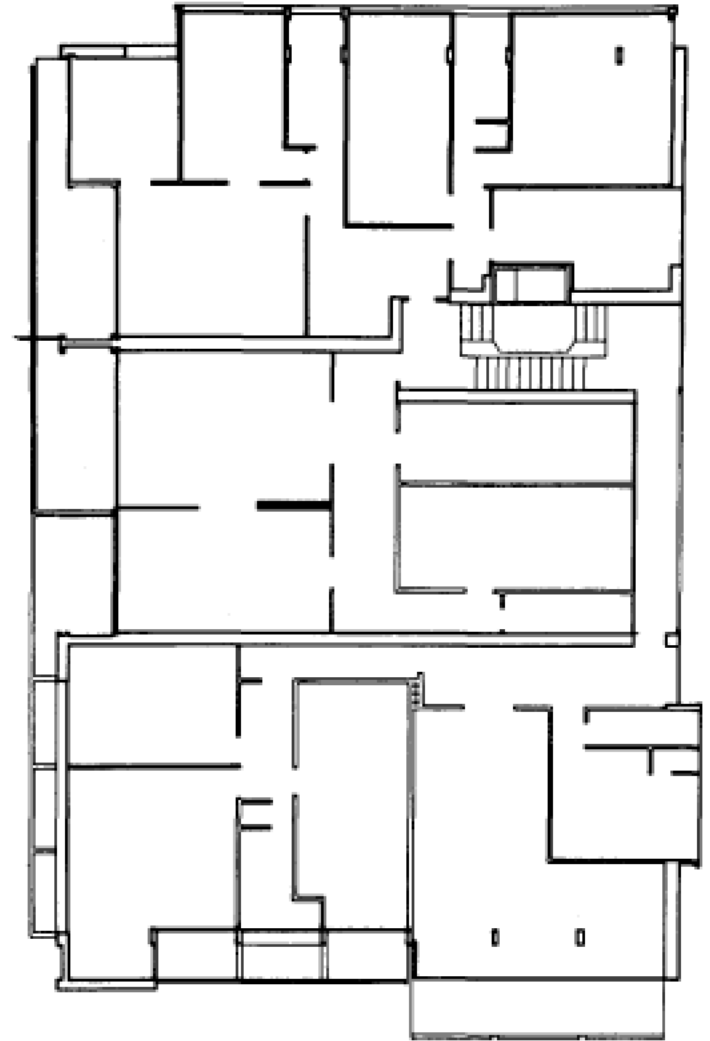
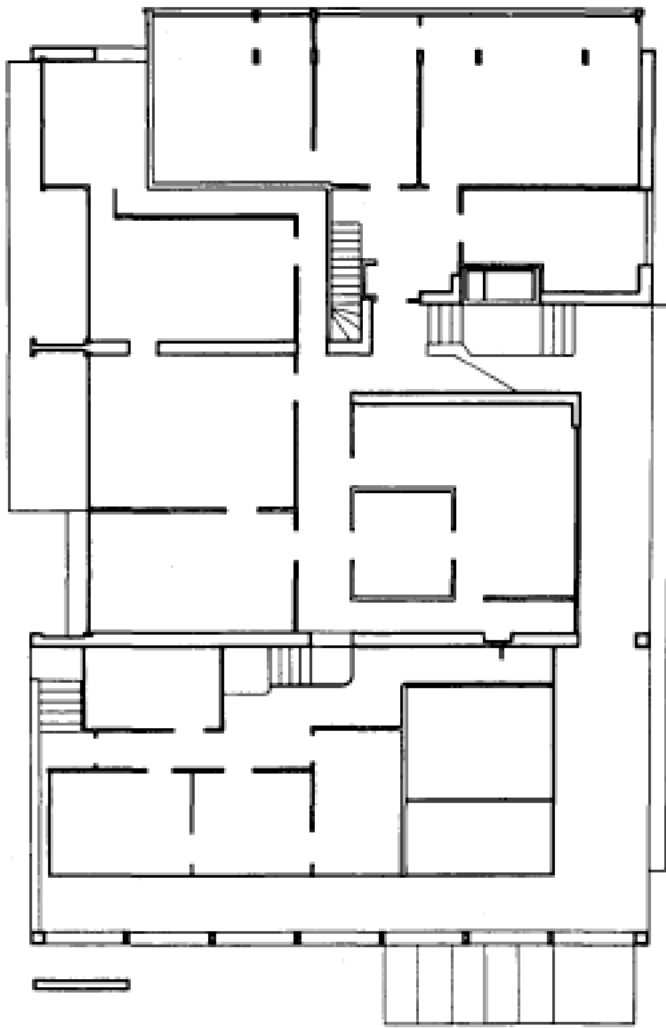

floor plans – *left: ground; right: upper floors*

defining columns

wall definition

wall labeling

wall development

wall connection

window designs

\oplus \square
(0, 0)

1

\oplus \square
(0, 0)

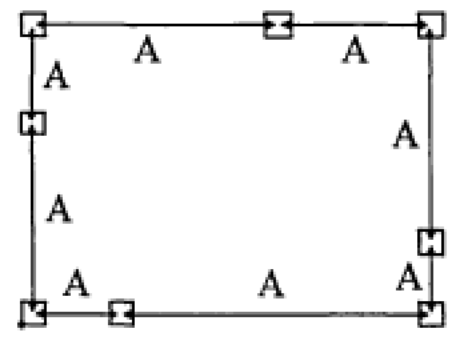

2

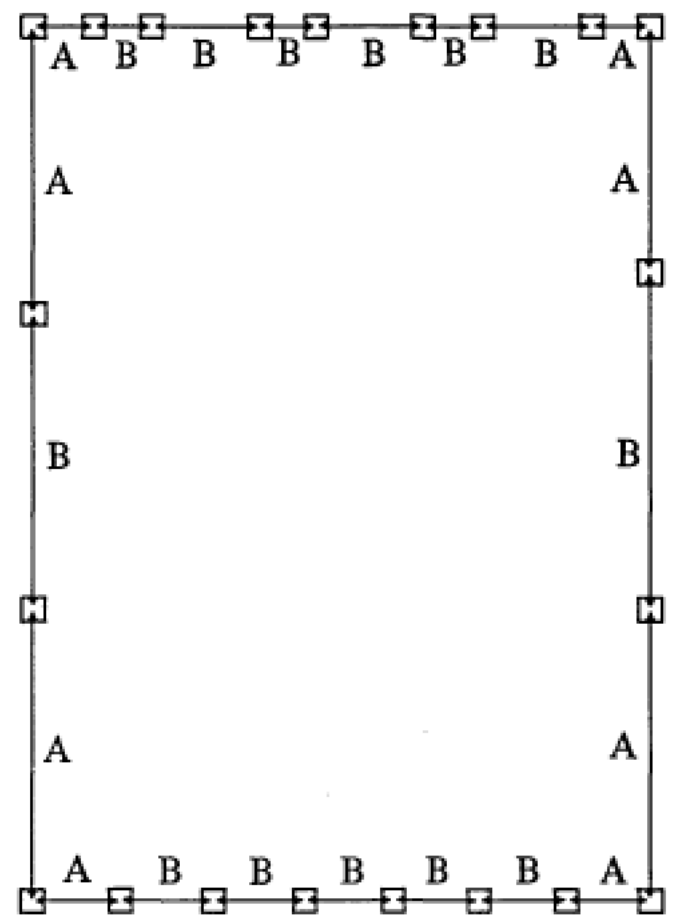
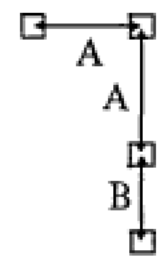
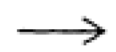
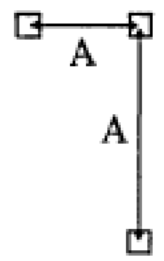

step 1: *defining columns*

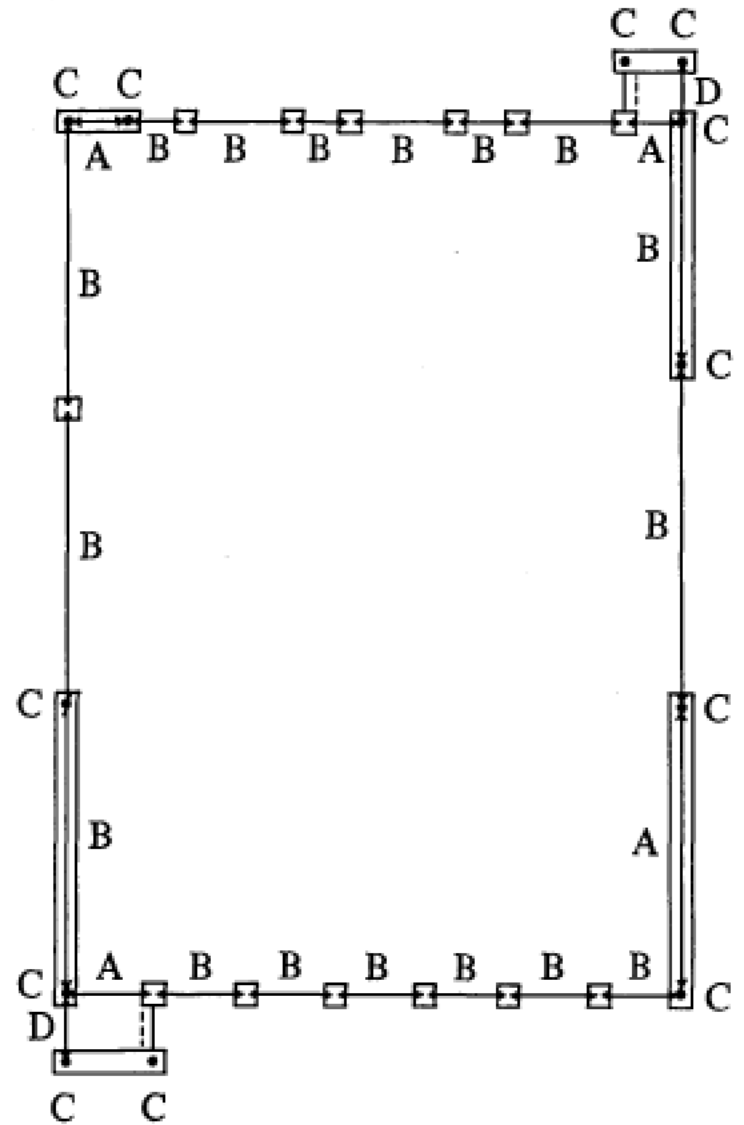
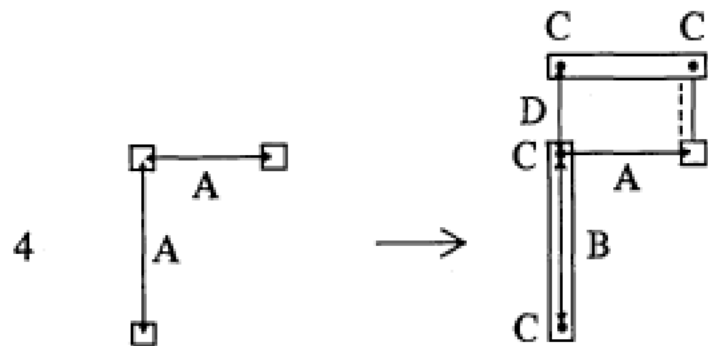
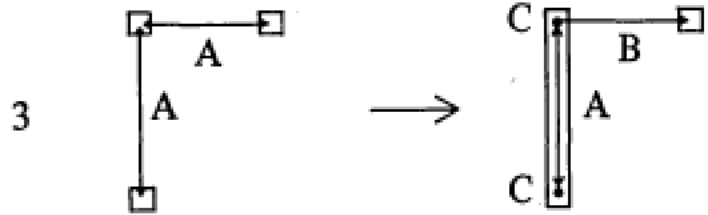

step 2: wall definition

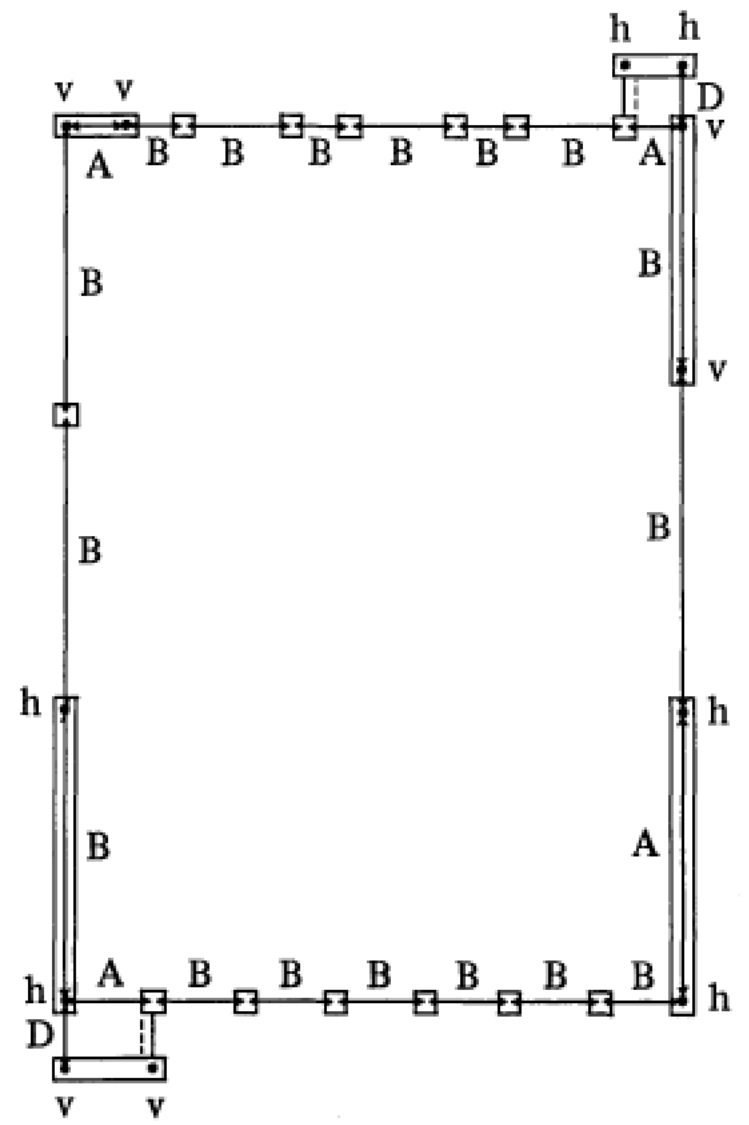
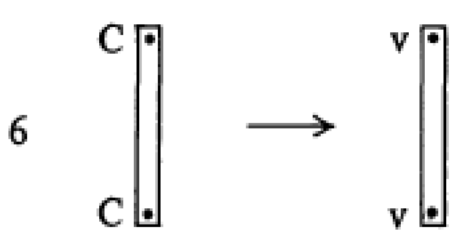
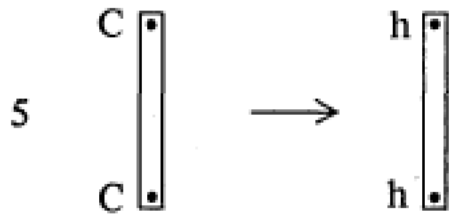

step 3: wall labeling

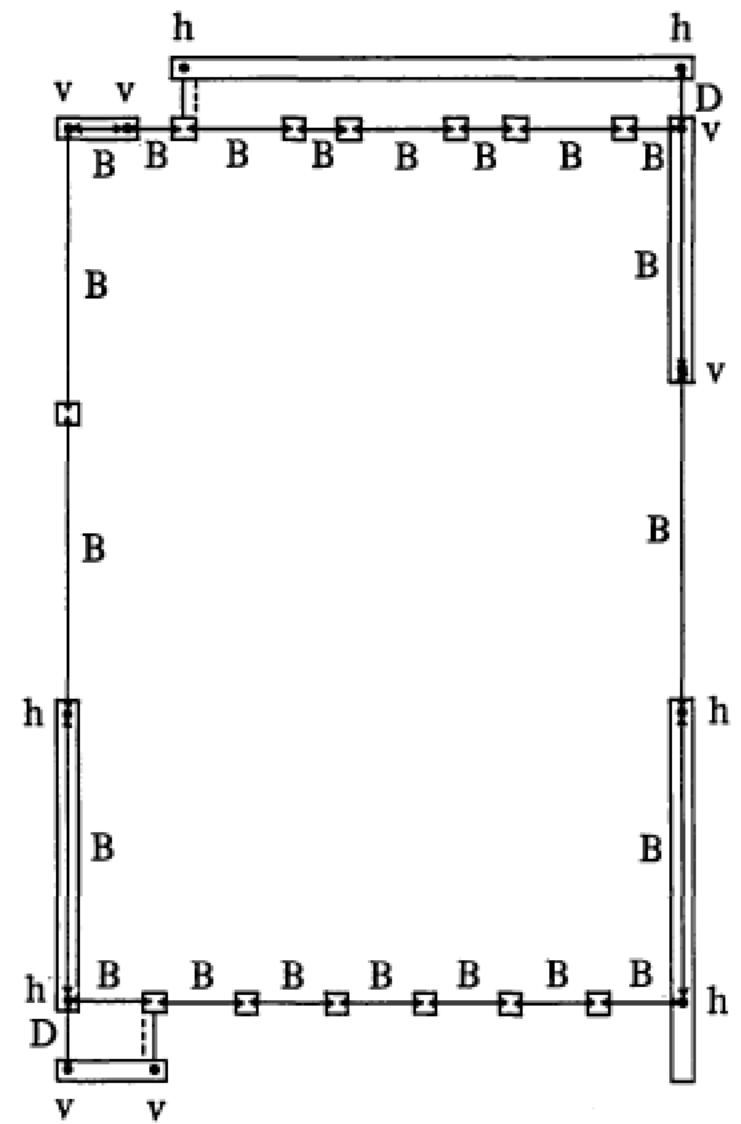
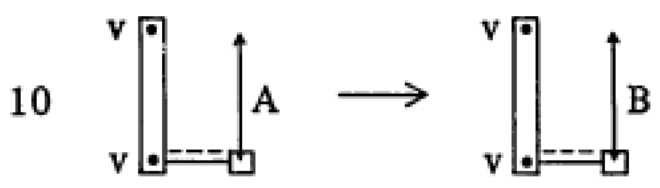
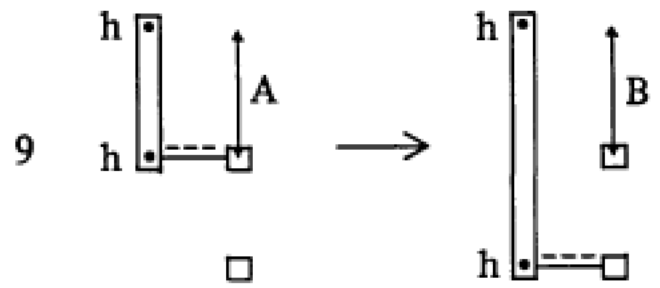
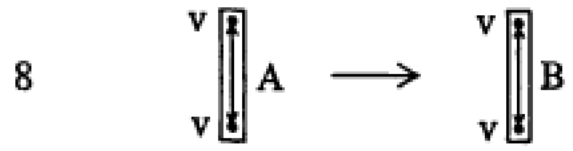
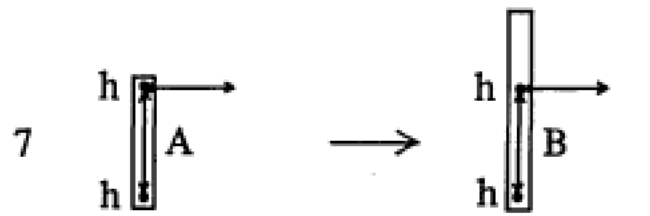

step 4: wall development

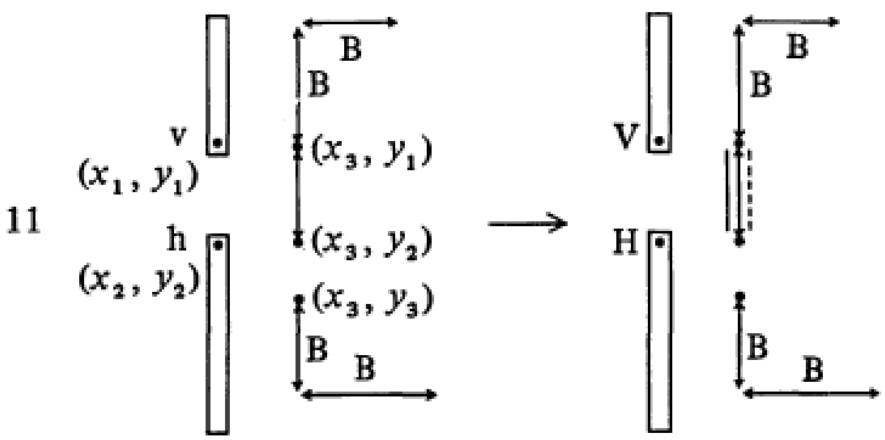

where $x_1 \leq x_3, x_2 \leq x_3, y_3 \leq y_2$

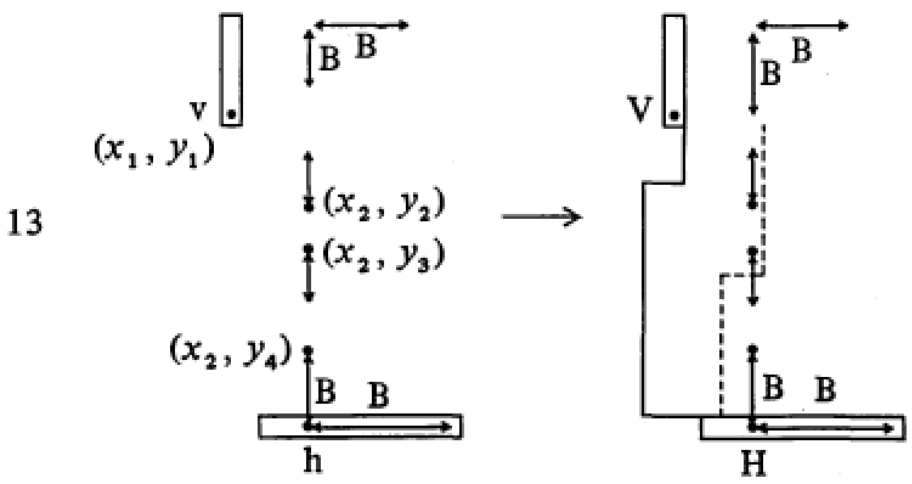

where $x_1 \leq x_2, y_3 \leq y_2, y_4 \leq y_3$

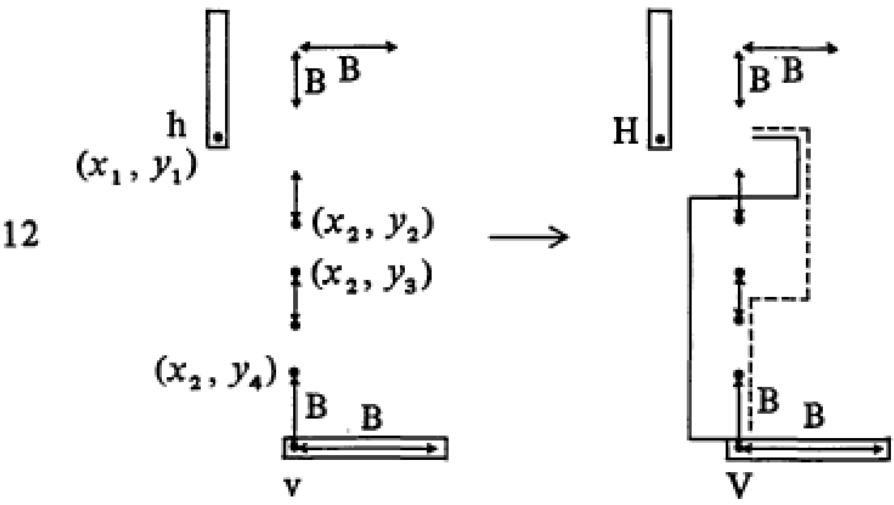

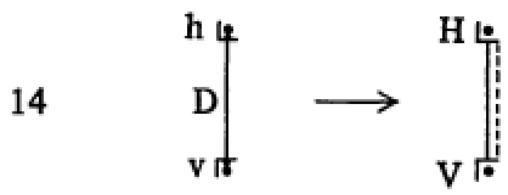

where $x_1 \leq x_2, y_3 \leq y_2, y_4 \leq y_3$

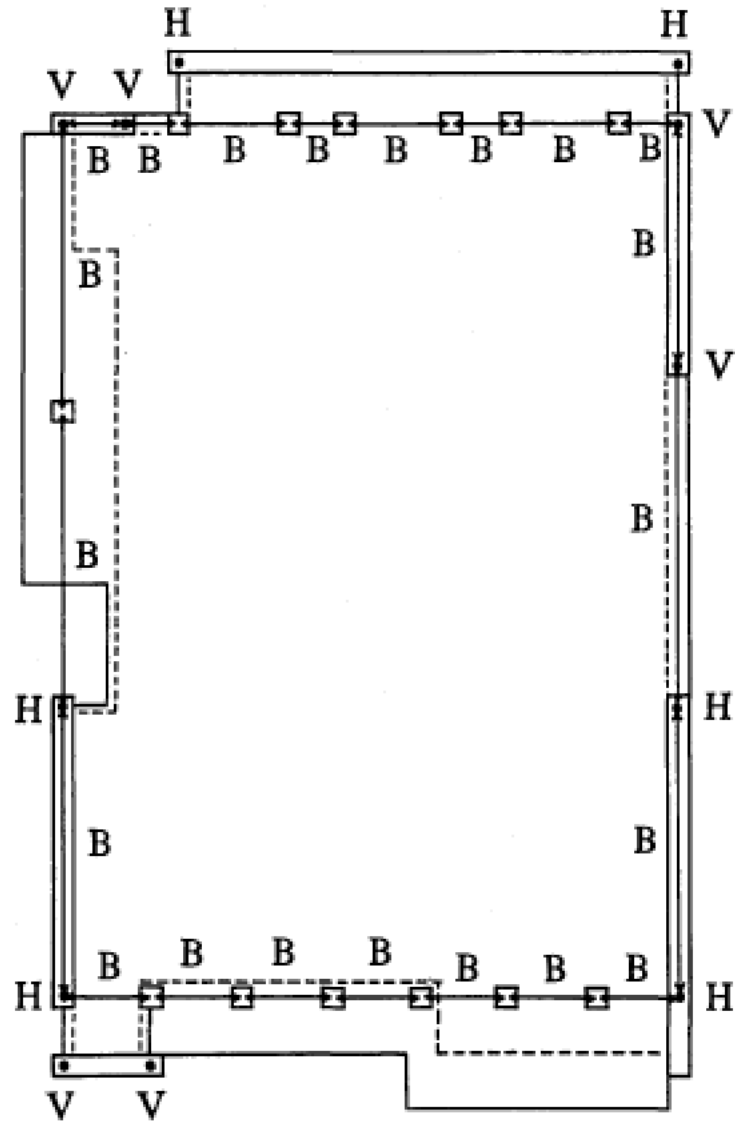

step 5: wall connection

$11^2, 12, 13, 14^2$



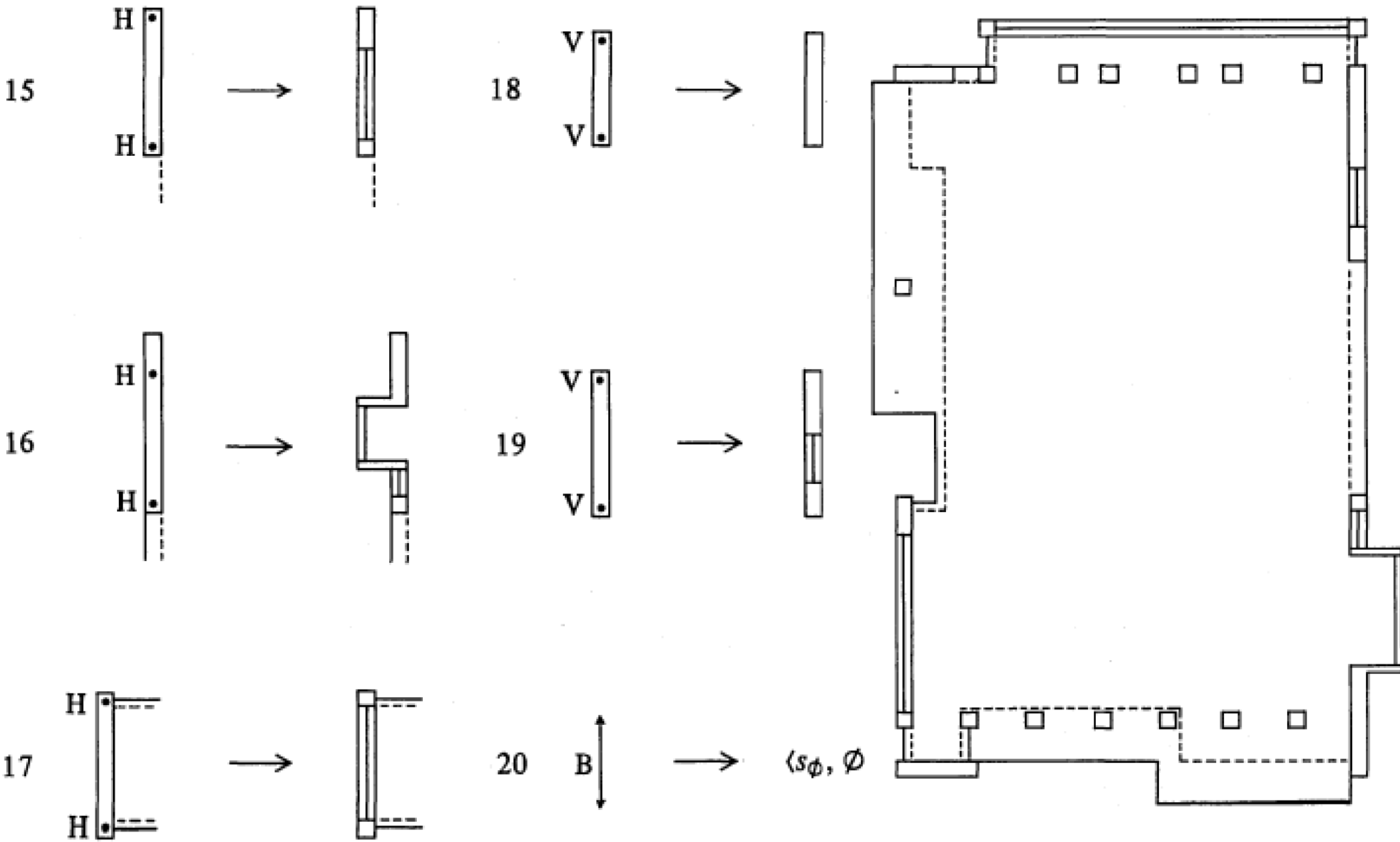

step 6: window designs

Vertical walls reach down to ground level and rise above ceiling of third floor.

Horizontal walls cannot reach below the first floor or above the ceiling of the third floor. Windows must have sills above floor level. Protruding alcoves do not touch alcoves above or below.

Columns reach down to ground level and rise above ceiling of third floor. If bay between columns is filled by a vertical wall, both columns must extend above that wall.

three dimensional realization - convention

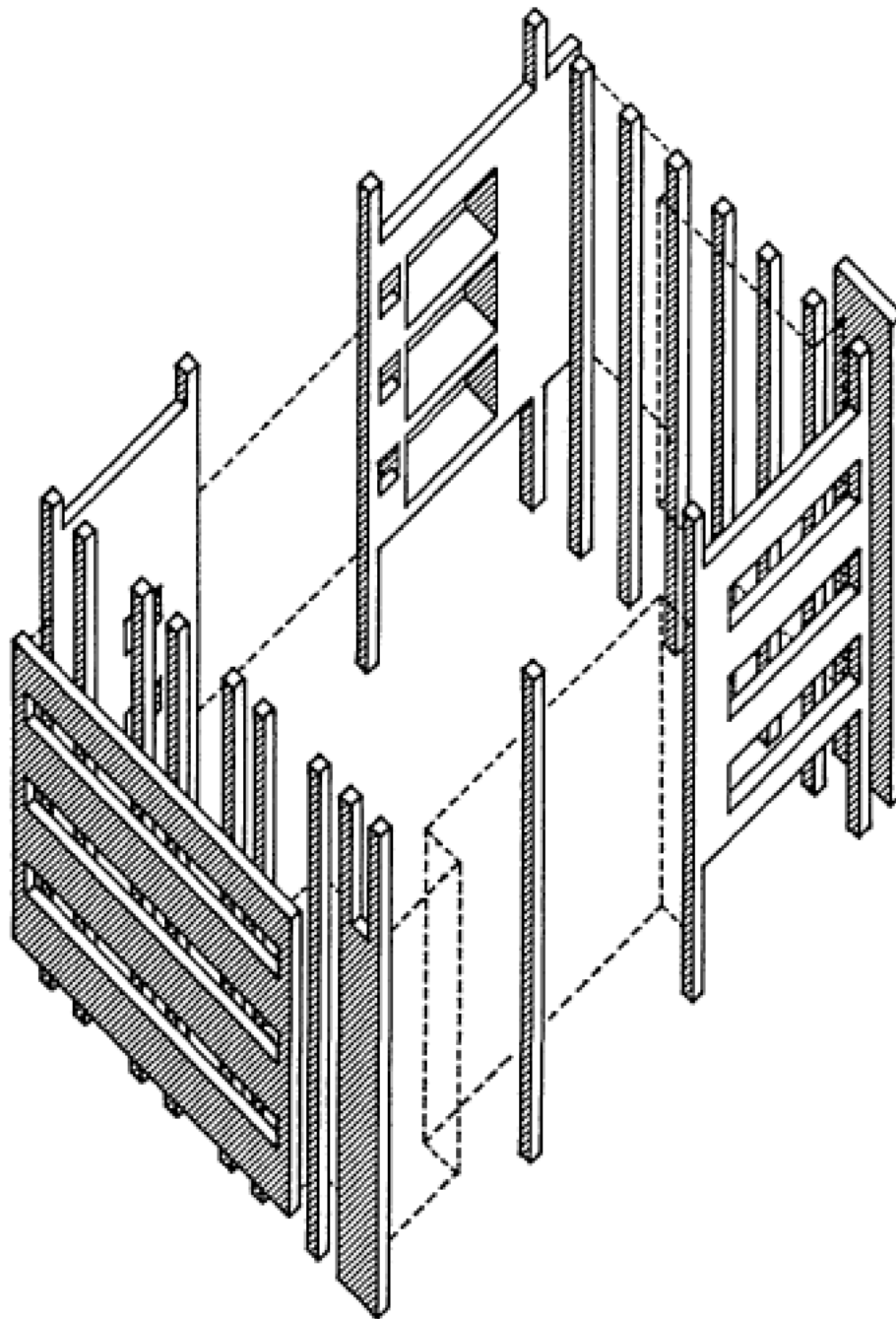

Vertical walls appear to rise from the ground to the roof inducing the observer to look up or down along their dominant dimension.

Horizontal walls seem to be suspended in the air or stretched out between columns; they might even cantilever past a corner of the cage.

The observer is induced to follow their main dimension from left to right or from right to left, an effect which is enhanced by the form of the windows and alcoves.

The grammar assures that horizontal and vertical walls alternate as one moves around the building: the contrast between these two types of elements is utilized in a very controlled manner.

no two corners of the building looks the same

3333

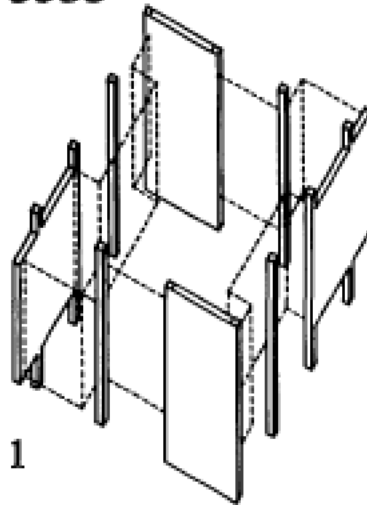

variations - how to make a corpus of one interesting

3344

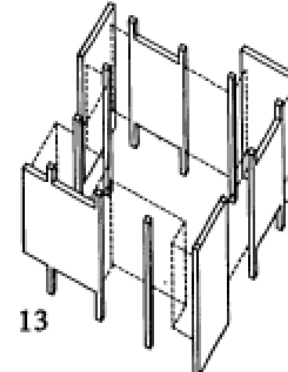
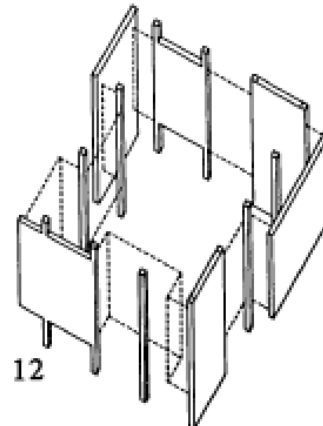
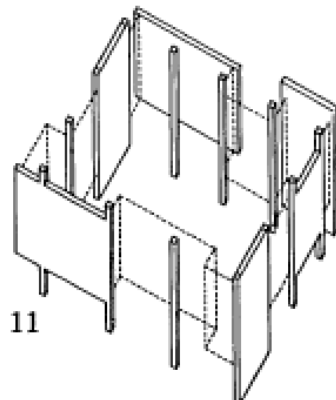
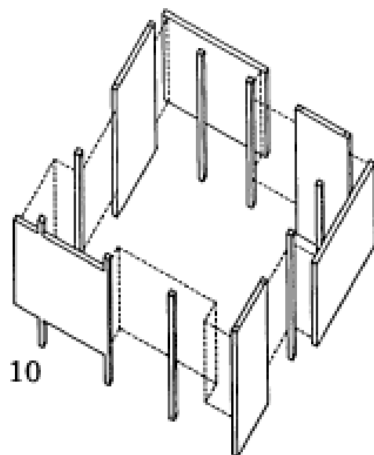
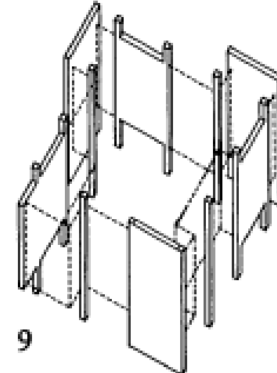
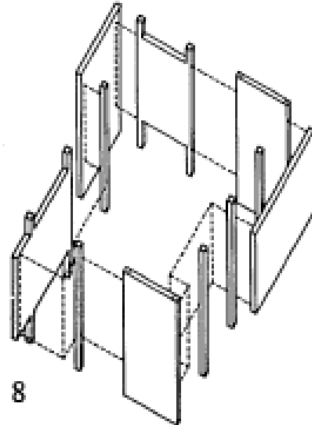
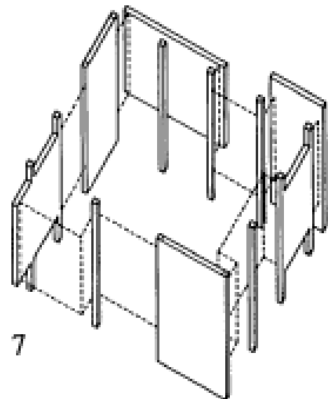
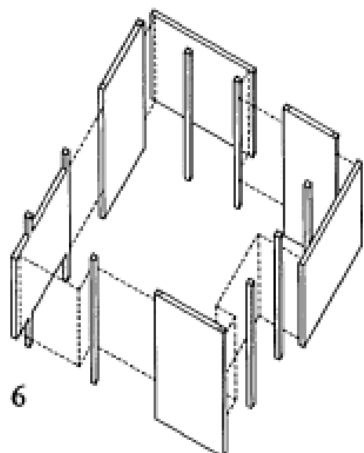
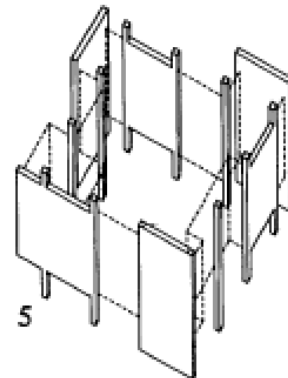
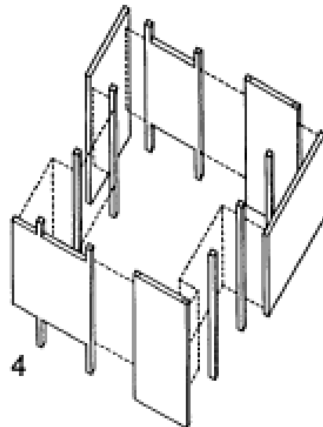
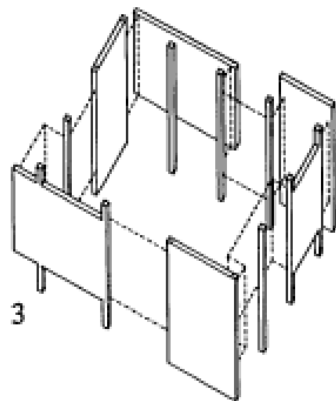
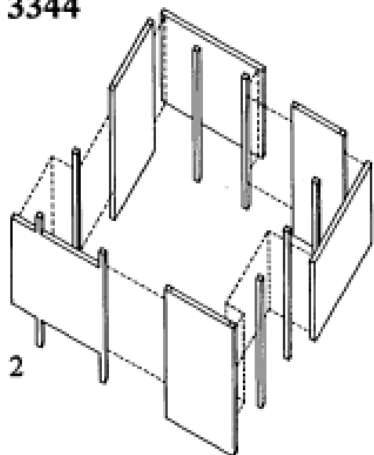

3434

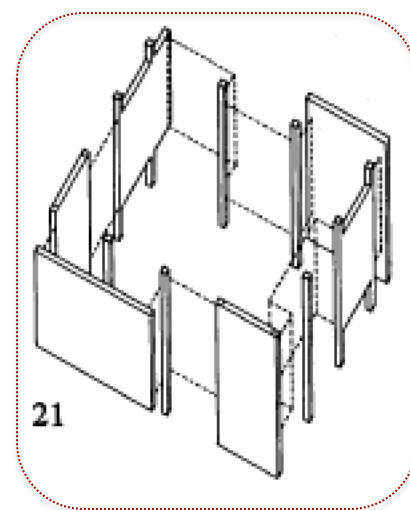
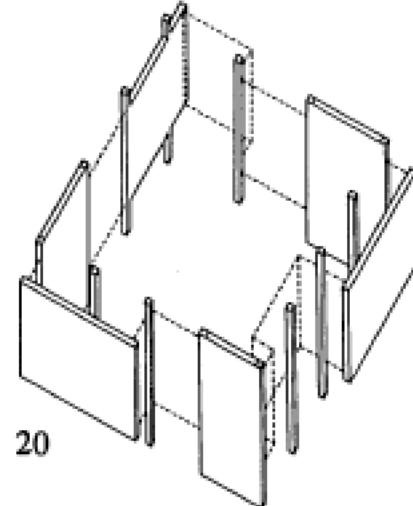
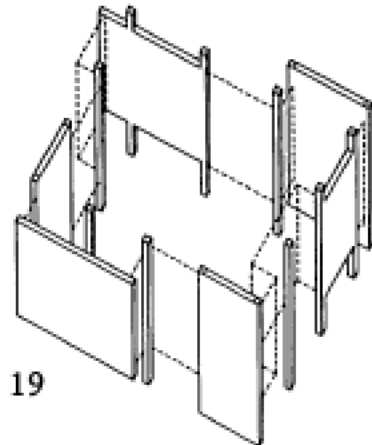
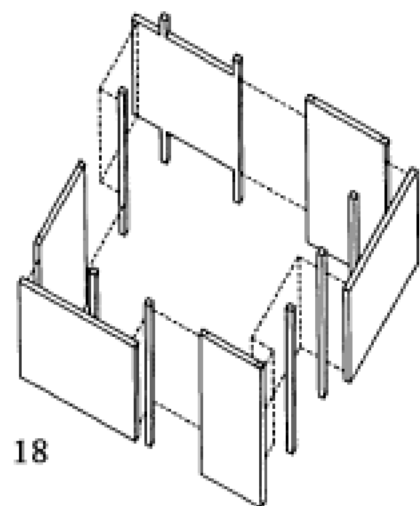
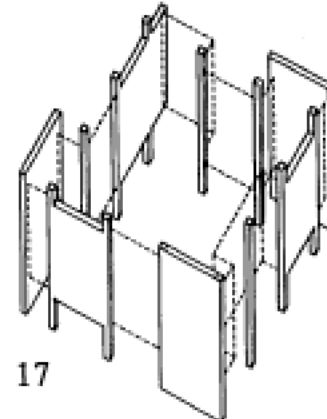
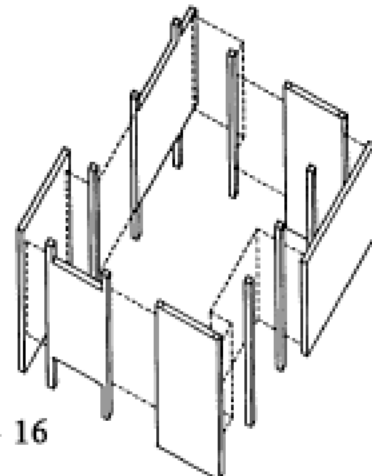
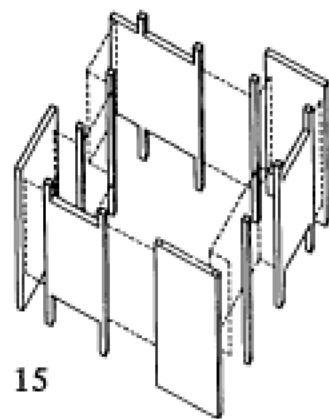
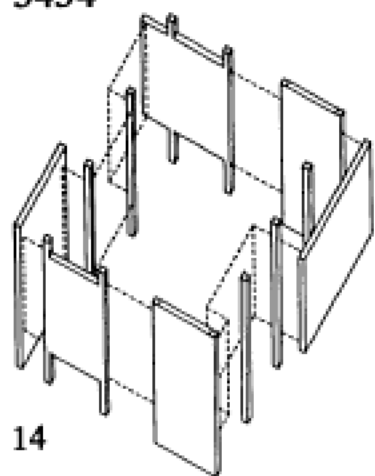

4444

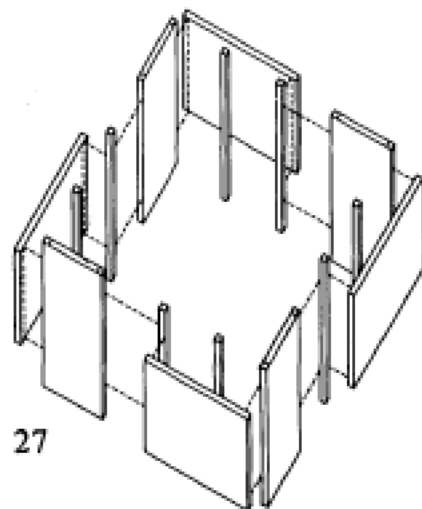
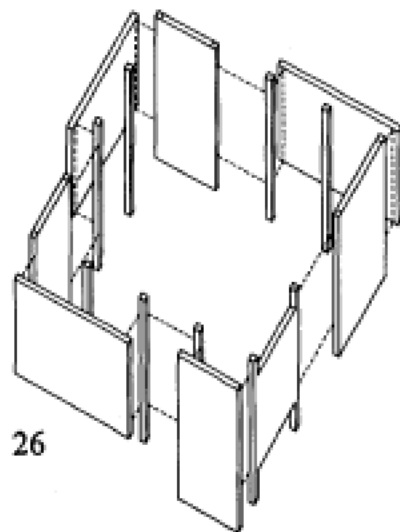
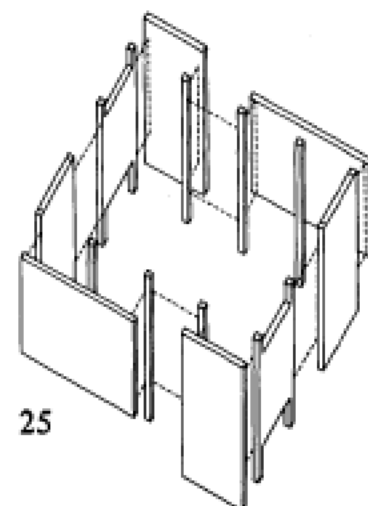
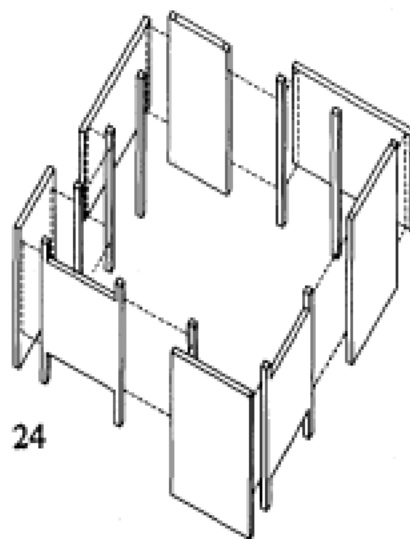
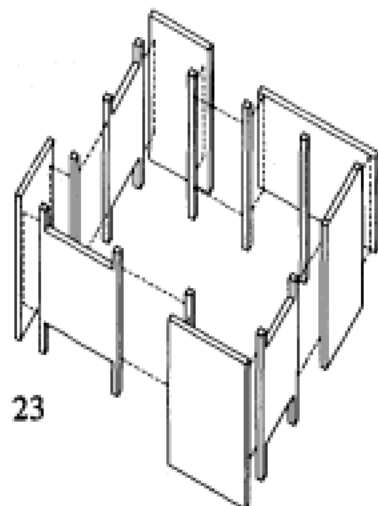
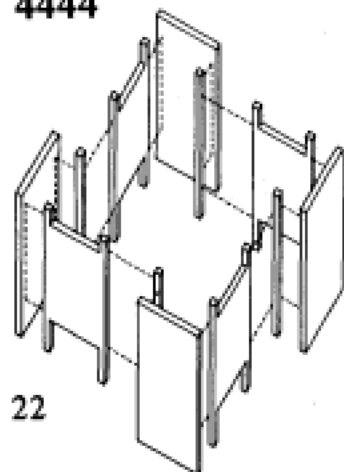

Each shape is a representative of an entire class of shapes which differ from each other only through properties neglected in the enumeration.

Grammar produces local contrasts at corners or within a facade, but does not prevent the repetition of wall configurations at different corners or the creation of rotational symmetries.

variations caused by rotations, reflections, dimensional differences or varying numbers of columns

Not all of the generated shapes display the range of contrasts found in Terragni's design – need to introduce schemata for tighter control of the more global properties of a shape.

The eight schemata used in stages 2-4 generate exactly four different wall configurations at the corner of a shape. These schemata could be replaced by four more powerful ones which would produce the outcomes of stages 2-4 in one step.

Ulrich's comments on p 96

These simple schemata isolate the principles found for the design under consideration and demonstrate how its apparent complexity can be explained through the combined effects of very simple operations.

Secret of Casa Giuliani Frigerio - ulrich' s comments on p 96