

A Geo-logical Solution to the Lottery Paradox, with Applications to Nonmonotonic Logic

Hanti Lin
Kevin T. Kelly*

January 17, 2011

Abstract

We defend a set of acceptance rules that avoids the lottery paradox, that is closed under classical entailment, and that accepts uncertain propositions without ad hoc restrictions. We show that the rules we recommend provide a semantics that validates exactly Adams' conditional logic and are exactly the rules that preserve a natural, logical structure over probabilistic credal states that we call *probalogic*. To motivate probalogic, we first expand classical logic to *geologic*, which fills the entire unit cube, and then we project the upper surfaces of the geological cube onto the plane of probabilistic credal states by means of standard, linear perspective, which may be interpreted as an extension of the classical condition of indifference. Finally, we apply the geometrical/logical methods developed in the paper to prove a series of trivialization theorems against question-invariance as a constraint on acceptance rules and against rational monotonicity as an axiom of conditional logic in situations of uncertainty.

1 The Lottery Paradox

If Bayesians are right, one's credal state should be a probability measure p over propositions, where probabilities represent degrees of belief. It seems that one also *accepts* propositions in light of p . Acceptance of proposition A is sometimes portrayed as a momentous inference making A certain, in the sense that one would bet one's life against nothing that A is true (e.g., Levi 1967). But that extreme standard would eliminate almost all ordinary examples of accepted propositions. We therefore entertain a more modest view of acceptance, according to which the set of propositions accepted in light

*This work was supported generously by the National Science Foundation under grant 0750681. Any opinions, findings, and conclusions or recommendations expressed in this material are those of the author(s) and do not necessarily reflect the views of the National Science Foundation.

of p should, in some sense, aptly capture some characteristics of p to others or, in everyday cognition, to ourselves. That view is non-inferential in the sense that p is not conditioned on the propositions accepted, but it is inferential in another sense—the accepted propositions may serve as premises in arguments whose conclusions are also accepted in the same, weak sense.

It seems that high probability short of full certainty suffices for acceptance, a view now referred to as the *Lockean thesis*. But the Lockean rule licenses acceptance of inconsistent sets of propositions, however high the threshold $r < 1$ is set. For there exists a fair lottery with more than $1/(1-r)$ tickets. It is accepted that some ticket wins, since that proposition carries probability 1. But for each ticket, it is also accepted that the ticket loses, since that proposition has probability greater than r . So an inconsistent set of propositions is accepted. That is Henry Kyburg’s (1961) *lottery paradox*.

To elude the paradox, one must abandon either the full Lockean thesis or classical consistency. Kyburg pursued the second course by rejecting the classical inference rule that A, B jointly imply $A \wedge B$, so that the collection of propositions of form “ticket i does not win” does not entail “no ticket wins”. Most responses side with classical logic and constrain the Lockean thesis in some manner to avoid contradictions. For example, Richard Jeffrey (1970) recommended that the entire practice of acceptance be abandoned in favor of reporting probabilities. Isaac Levi (1967) rejected the idea that acceptance can be based on probability alone, since utilities should also be consulted. Or one may impose as a necessary condition that accepted propositions be certain (van Fraassen 1995, Arló-Costa and Parikh 2005) or to cases in which no logical contradiction happens to result (Pollock 1995, Ryan 1996, and Douven 2002).

Our approach is different. Instead of restricting the Lockean thesis, we *revise* it. In particular, we defend an *unrestricted* rule of acceptance that is *contradiction-free* and yet capable of accepting *uncertain* propositions—even propositions of fairly low probability. Like the Lockean rule, the proposed rule has a parameter that controls its strictness. When the parameter is tuned toward 1, the proposed rule is almost indistinguishable from the classical logical closure of the Lockean rule; but as the parameter drops toward 0, the proposed rule’s geometry shifts steadily away from that of the Lockean rule so as to avert the lottery paradox.

The rule we recommend was invented by Isaac Levi (1996: 286), who saw no justification for it except as a loose approximation to an alternative rule he took to be justified by decision-theoretic means (1967, 1969).¹ We provide a justification of the

¹Levi writes: “I do not know how to derive it from a view of the cognitive aims of inquiry [i.e. seeking more information and avoiding error] that seems attractive.” (1996: 286) We rediscovered the rule as a consequence of our work on Ockham’s razor. The problem was to extend the Ockham efficiency theorem (Kelly 2008) from methods that choose theories to methods that update probabilistic degrees of belief on theories. That required a concept of retraction of credal states, expounded in (Kelly 2010). We thank Teddy Seidenfeld for bringing the prior publication of the rule to our attention.

rule in terms of *preservation of logical structure* implicit in the space of probabilistic credal states. The crux is to order probabilistic credal states according to relative logical strength, as Boolean algebra does for propositions. We do so in two steps. First, we start with a sigma algebra of propositions (closed under negation and countable disjunction) and then *extend* that sigma algebra to cover the entire unit cube by introducing a new connective \neg_d interpreted as negation to *degree* d , so that $\neg_0\phi$ is equivalent to ϕ and $\neg_1\phi$ is equivalent to $\neg\phi$. The resulting logical structure is called *geologic* (section 4). Next, we *view* the geological structure *in perspective* through the *picture plane* of possible credal states to obtain a logical structure over credal states that we call *probalogic* (sections 5 and 6). Then it is natural to require that every rule of acceptance preserves probalogical structure when it maps probabilistic credal states to standard, Boolean propositions.

The requirement that acceptance rules preserve probalogical structure has appealing consequences for the theory of acceptance. First, we show that the rules we recommend are exactly the rules that preserve probalogical structure (section 7). Moreover, there is no plausible logical structure on probability measures that the Lockean rule and its variants can be said to preserve (section 8).

Another justification of the proposed acceptance rules concerns the logic of conditionals and defeasible reasoning. Frank P. Ramsey proposed an influential, epistemic condition for acceptance of conditional statements, now commonly referred to as the *Ramsey test*:

If two people are arguing ‘If A , then B ?’ and are both in doubt as to A , they are adding A hypothetically to their stock of knowledge and arguing on that basis about B ; so that in a sense ‘If A , B ’ and ‘If A , $\neg B$ ’ are contradictories. We can say that they are fixing their degree of belief in B given A . (Ramsey 1929, footnote 1)²

Suppose that an agent is in a probabilistic credal state p and adopts a certain acceptance rule. We propose the following interpretation of the Ramsey test: the agent accepts the (flat) conditional (or implication) ‘if A then B ’ when, by the acceptance rule she adopts, she would accept B in the credal state $p(\cdot|A)$ that results from p by conditioning on A . Thus, conditional acceptance is reduced to Bayesian conditioning and acceptance of non-conditional propositions. This natural semantics allows one to characterize the axioms of conditional logic in terms of the geometrical constraints on acceptance rules that validate them, in much the same way that axioms of modal logic are standardly characterized in terms of constraints on accessibility among worlds. Accordingly, we solve for the geometrical constraints imposed on acceptance rules by each of the axioms in Adams’ (1975) logic of conditionals (section 9). These constraints

²We take the liberty of substituting A, B for p, q in Ramsey’s text.

are shown to be satisfied by the rules that preserve probalogical structure, so the probalogic-preserving rules validate Adams' logic with respect to the Ramsey test (section 10). Conversely, Adams' logic is shown to be *complete* with respect to the Ramsey test when acceptance follows probalogic-preserving rules (section 12). The result is a new probabilistic semantics: it defines validity simply as preservation of acceptance, which improves upon Adams' (1975) ϵ - δ semantics; and it allows for accepting propositions of low probabilities, which improves upon Pearl's (1989) infinitesimal semantics. Thus, the recommended acceptance rules are vindicated both by probalogic and by conditional logic.

One might hope for validating a stronger conditional logic than Adams', e.g. the system R (Kraus and Magidor 1992) or, equivalently, the AGM axioms for belief revision (Harper 1975, Alchourron, Gardenfors, and Makinson 1985). We close the door on that hope with a new trivialization theorem (section 11), employing the geometrical techniques described above. In light of that result, we propose that Adams' conditional logic reflects Bayesian ideals better than AGM belief revision does.

Finally, the acceptance rules we recommend are sensitive to framing effects determined by an underlying question. One might hope that the advantages of the proposed rules could be obtained without question-dependence. Again, we close the door on that hope with a series of trivialization theorems (sections 13 and 14). We conclude that, all things considered, the advantages of the recommended acceptance rules within questions justify their dependence on questions.

2 The Geometry of the Lottery Paradox

Let $\mathcal{E}_\kappa = \{E_i : i \in I\}$ be a countable collection of mutually exclusive and jointly exhaustive propositions over some underlying set of possibilities, where κ (either ω or some finite n) is the cardinality of the index set I .³ We think of \mathcal{E}_κ as a *question* in context whose *potential answers* are the various E_i . Let \mathcal{A}_κ be the least collection of propositions containing \mathcal{E}_κ that is closed under negation and countable disjunction and conjunction, and let \mathcal{P}_κ denote the set of all (countably additive) probability measures defined on \mathcal{A}_κ . We think of \mathcal{P}_κ as the space of *probabilistic credal states* over answers to question \mathcal{E}_κ . The subscripts are suppressed in the sequel unless we wish to emphasize cardinality.

We assume that acceptance rules produce sets of propositions that are closed under classical entailment so that, without loss of generality, each acceptance rule may be viewed as a map $\alpha : \mathcal{P} \rightarrow \mathcal{A}$, where proposition $\alpha(p)$ is understood as the strongest proposition accepted in light of probability measure p . Then proposition A is *accepted*

³Note that in the mathematics that follows, we never distinguish between questions of a given cardinality, so no confusion results from identifying questions in terms of cardinality.

by rule α at credal state p , written $p \Vdash_{\alpha} A$, if and only if $\alpha(p)$ entails A . The *acceptance zone* of A under α is defined as the set of all credal states at which A is accepted by α .

For example, the *Lockean* acceptance rule with threshold set to r in the unit interval is just the mapping:

$$\lambda_r(p) = \bigwedge \{A \in \mathcal{A} : p(A) \geq r\}. \quad (1)$$

Each probability measure p in \mathcal{P} can be represented with respect to \mathcal{E} as the κ -dimensional vector $(p(E_i) : i \in I)$ with components in the unit interval summing to one. In the context of question \mathcal{E} , we identify p with its vector, so that the i -th component p_i equals $p(E_i)$. When $\kappa = 3$, for example, \mathcal{P}_3 corresponds to the set of all such 3-vectors, which is the equilateral triangle in \mathbb{R}^3 whose corners have Cartesian coordinates $e_1 = (1, 0, 0)$, $e_2 = (0, 1, 0)$ and $e_3 = (0, 0, 1)$ (figure 1). To avoid ambiguity, we let $(e_i)_j$ pick out the j -th component of e_i . Reformulate the Lockean rule (1) as

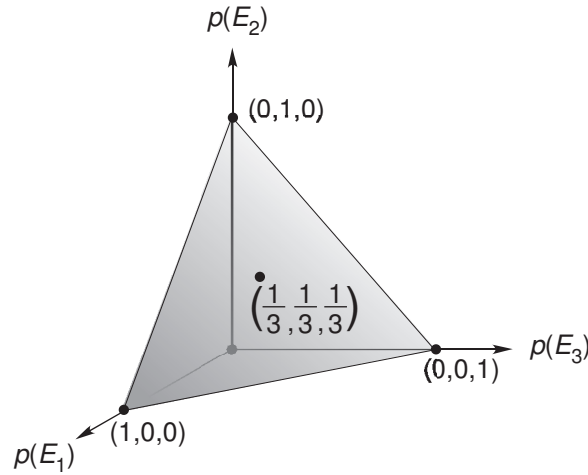

Figure 1: the space \mathcal{P}_3 of probabilistic credal states

follows:⁴

$$\lambda_r(p) = \bigwedge \{\neg E_i : 1 - p_i \geq r \text{ and } i \in I\}; \quad (2)$$

$$= \bigwedge \{\neg E_i : p_i \leq 1 - r \text{ and } i \in I\}. \quad (3)$$

By this formulation, the acceptance zone of $\neg E_1$ under λ_r with respect to question \mathcal{E}_3 is depicted in figure 2. The Lockean rule is now expressed *geometrically*—its acceptance

⁴This is equivalent to the original formulation because, first, every proposition A is equivalent to the conjunction of all propositions of form $\neg E_i$ that are entailed by A and, second, propositions of form $\neg E_i$ that are entailed by A are at least as probable as A .

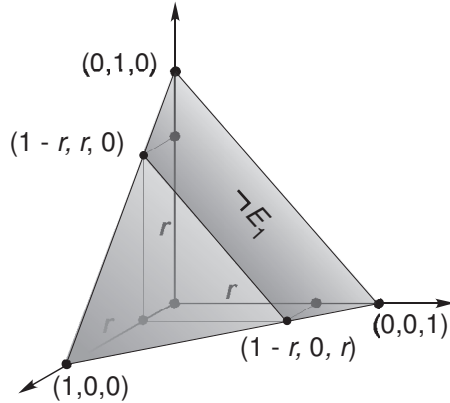

Figure 2: acceptance zone for $E_2 \vee E_3$ under λ_r

zone for $\neg E_1$ has a definite, trapezoidal *shape* that results from truncating the triangular space \mathcal{P}_3 parallel to one side. As threshold r is dropped, the trapezoid becomes thicker. The acceptance zones of $\neg E_2$ and $\neg E_3$ are included in figure 3.a. By closure under entailment, proposition E_1 is accepted exactly when both $\neg E_2$ and $\neg E_3$ are accepted, so the corner, diamond-shaped zones license acceptance of potential answers to \mathcal{E} . When

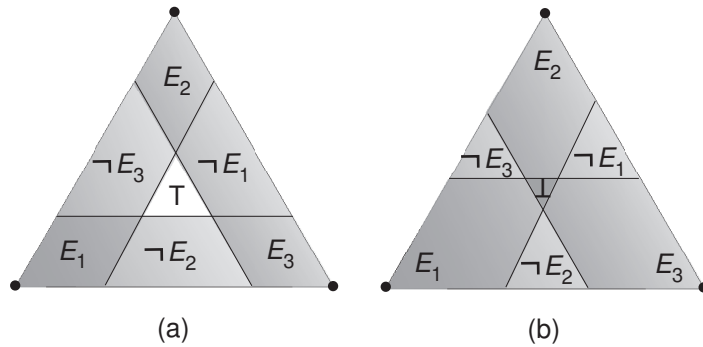

Figure 3: acceptance zones under λ_r

$r \leq 2/3$, the propositions $\neg E_1, \neg E_2, \neg E_3$ are all accepted at the probability measures contained in the small, dark, central triangle (figure 3.b). But that set of propositions is inconsistent so, by closure under entailment, the dark, central triangle is the acceptance zone of the inconsistent proposition \perp . That is just the lottery paradox for thresholds $r \leq 2/3$ (interpret E_i as the proposition “ticket i wins”).

Geometrically, the lottery paradox arises because the Lockean rule’s acceptance zones for the various propositions $\neg E_i$ crash clumsily into one another as the prob-

ability threshold r decreases. It is easy to design alternative acceptance zones that *bend* progressively as they approach the center of the triangle so that they eventually meet without overlapping like the leaves of a camera shutter (figure 4). The proposed

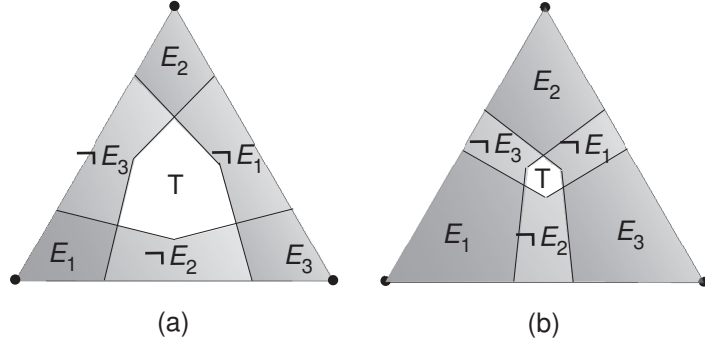

Figure 4: progressively bent zones that avert collision

acceptance zones are almost indistinguishable from those of the Lockean rule when r is close to 1. As r approaches 0, the bending becomes more pronounced and the lottery paradox is avoided.

A special, symmetric case of the proposed rule, which we call the *symmetric camera shutter rule*, modifies the Lockean rule as follows. Test whether answer E_i to \mathcal{E} should be rejected at credal state p by considering, not probability p_i itself, but the probability ratio:

$$\sigma(p)_i = \frac{p_i}{\max_j p_j},$$

resulting in the modified rule:

$$\nu_r(p) = \bigwedge \{ \neg E_i : \sigma(p)_i \leq 1 - r \text{ and } i \in I \}. \quad (4)$$

The symmetric camera shutter rule is algebraically the same as the Lockean rule (3) except that probability is divided by the probability distribution's mode. Say that acceptance rule α is *everywhere consistent* if and only if $p \not\llcorner_\alpha \perp$ for each p in \mathcal{P} , and say that α is *non-skeptical* if and only if for each E_i in \mathcal{E} there exists p in \mathcal{P} such that $p(E_i) < 1$ and $p \Vdash_\alpha E_i$. Then:

Proposition 1. *Let \mathcal{E} contains at least two answers. The symmetric camera shutter rule ν_r is everywhere consistent and non-skeptical, for each r such that $0 < r < 1$.*

Proof. For everywhere consistency, note that since $\sum_i p_i = 1$, so there exists $i \in I$ such that $p_i = \max_j p_j$. Then, since $r > 0$,

$$\sigma(p)_i = 1 \not\leq 1 - r,$$

so $p \not\|_{\nu_r} \neg E_i$, by formula (4). It follows that $p \not\|_{\nu_r} \perp$. For non-skepticism, let E_i be an arbitrary answer, and it suffices to show that E_i is accepted by ν_r at some credal state p such that $p_i < 1$. Let $p_i = 1/(2-r)$. Since \mathcal{E} contains at least two answers, choose j in I distinct from i and let $p_j = (1-r)/(2-r)$. Since a probability distribution is normalized, $p_k = 0$ for all $k \neq i, j$. Note that p_i is the mode of p , since $r > 0$. So for each $k \neq i$:

$$\begin{aligned}\sigma(p)_k &\leq 1-r, \\ \sigma(p)_i &= 1 \not\leq 1-r,\end{aligned}$$

since $r > 0$. Hence $p \Vdash_{\nu_r} E_i$, by formula (4), with $p_i = 1/(2-r) < 1$, since $r < 1$. \square

On the other hand:

Proposition 2. *Suppose that \mathcal{E} is countably infinite. The Lockean rule λ_r is either skeptical or somewhere inconsistent, for each r such that $0 \leq r \leq 1$.*

Proof. If Lockean rule is not skeptical, then $r < 1$, and thus there exists p in \mathcal{P}_ω such that $p_i \leq 1-r$, for each $i \in I$. So by formula (3), $\lambda_r(p) = \perp$, and hence λ_r is somewhere inconsistent. \square

3 Respect for Logic

The range of acceptance rule $\alpha : \mathcal{P} \rightarrow \mathcal{A}$ has a natural, Boolean logical structure:

$$(\mathcal{A}, \leq, \vee, \wedge, \perp, \top),$$

where the partial order \leq corresponds to classical entailment or relative strength of propositions and \vee and \wedge are the least upper bound and the greatest lower bound with respect to \leq , which correspond to the usual propositional operations of disjunction and conjunction.⁵ If there were also a motivated logical structure on the space:

$$(\mathcal{P}, \leq, \vee, \wedge, \perp, \top)$$

of probabilistic credal states, in which \leq is intended, again, to reflect relative strength, then an obvious constraint on acceptance rules would be to *preserve* logical structure

⁵In algebraic logic, $A \leq B$ means that A is at least as strong as B .

in the sense that:

$$p \leq q \Rightarrow \alpha(p) \leq \alpha(q); \quad (5)$$

$$\alpha(p \vee q) = \alpha(p) \vee \alpha(q); \quad (6)$$

$$\alpha(p \wedge q) = \alpha(p) \wedge \alpha(q); \quad (7)$$

$$\alpha(e_i) = E_i; \quad (8)$$

$$\alpha(\top) = \top; \quad (9)$$

$$\alpha(\perp) = \perp. \quad (10)$$

Any plausible logical structure over \mathcal{P} should also satisfy the following constraint:

$$\text{the unit vectors } e_i, \text{ for } i \in I, \text{ are exactly the strongest credal states in } \mathcal{P}. \quad (11)$$

Then we already have the following assurance against inconsistency:

Proposition 3 (no lottery paradox). *Suppose that acceptance rule α and relative strength \leq over \mathcal{P} satisfy conditions (5), (8), and (11). Then α is everywhere consistent.*

Proof. Suppose for reductio that for some credal state p , $\alpha(p) = \perp$. Then, by condition (11), there exists a strongest state e_i such that $e_i \leq p$. So $\alpha(e_i) \leq \alpha(p)$, by (5). Then by (8), we have that $E_i = \alpha(e_i) \leq \alpha(p) = \perp$. So $E_i \leq \perp$, which is false in the Boolean logical structure of \mathcal{A} . \square

Therefore, the lottery paradox witnesses the failure of the Lockean rule to preserve logical structure. But the lottery paradox is only the most glaring consequence of the Lockean rule's disrespect for logical structure. It is plausible to suppose that with respect to question \mathcal{E} , if credal state p accords maximal probability to answer E_i , compared to all the alternative answers to \mathcal{E} , and if E_j is a distinct answer to \mathcal{E} , then credal state $p(\cdot|\neg E_j)$ is at least as strong as p :

$$p_i = \max_k p_k \text{ and } E_i \neq E_j \implies p(\cdot|\neg E_j) \leq p. \quad (12)$$

But then the Lockean rule again fails to preserve relative strength, i.e., it violates condition (5). Recall from figure 3 that a consistent Lockean rule's acceptance zone for E_2 is a diamond. The diamond has the wrong shape—its sides meet at an angle that is too acute. For consider a credal state p very close to the inner apex of the diamond, as depicted in figure 5. Let $q = p(\cdot|\neg E_3)$. By condition (12), we have that $q \leq p$. But point q lies on the side of the triangle opposite e_3 because $q_3 = 0$, and q lies on the ray from e_3 that passes through p because $q_1/q_2 = p_1/p_2$. So $\lambda(q) = \neg E_3 \not\leq E_2 = \lambda(p)$. Therefore, $q \leq p$ but $\lambda(q) \not\leq \lambda(p)$, which violates (5). That is another, counterintuitive way to fail to preserve logical order even when the lottery paradox does not arise.

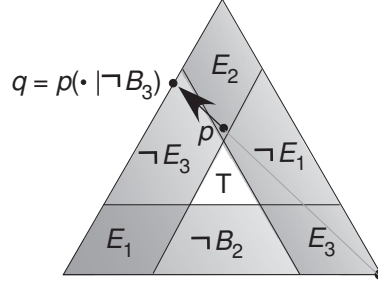

Figure 5: deeper trouble for the Lockean rule

The preceding argument illustrates a further point: intuitions about relative strength of credal states are tied to conditioning. The boundaries of acceptance zones determined by the Lockean rule do not follow the geometrical rays that correspond to the trajectories of probabilistic credal states under conditioning. For that reason, the Lockean rule is a bad choice for trying to explicate the acceptance of conditionals in terms of conditional probabilities. Specifically, consider the following interpretation of the Ramsey test. The *consequence relation* $\sim_{\alpha,p}$ on the set \mathcal{A} of propositions with respect to acceptance rule α and credal state p is defined by:⁶

$$A \sim_{\alpha,p} B \iff p(\cdot|A) \Vdash_{\alpha} B \text{ or } p(A) = 0. \quad (13)$$

The Ramsey test is then interpreted as saying that $A \sim_{\alpha,p} B$ is a necessary and sufficient condition for the agent to accept flat conditional ‘if A then B ’. Consider again the consistent Lockean rule λ and credal state p in figure 5. Then, as evident from the picture, we have:

$$\begin{array}{l} \top \sim_{\lambda,p} E_2, \\ \top \sim_{\lambda,p} \neg E_3, \\ \neg E_3 \not\sim_{\lambda,p} E_2. \end{array}$$

But this violates the following, familiar axiom in the logic of flat conditionals and defeasible reasoning (let $A = \top$, $B = E_2$, and $C = \neg E_3$):

$$\text{(Cautious Monotonicity)} \quad \frac{A \sim B \quad A \sim C}{A \wedge C \sim B}$$

On the other hand, conditions (5) and (12) suffice to validate Cautious Monotonicity. For by (12), credal state q would have been at least as strong as credal state p and hence, by (5), any proposition accepted in p is also accepted in q , e.g., E_2 .

⁶If $p(A) \neq 0$, $p(\cdot|A)$ is defined to be $p(\cdot \wedge A)/p(A)$; otherwise it is undefined.

The angles formed by the sides of the acceptance zones are crucial to the preservation of logical structure. The acceptance rules we recommend—the camera shutter rules—do have acceptance zones with the correct angles at their corners and, therefore, do not encounter any of the preceding logical difficulties. We will show that the camera shutter rules preserve a very natural logical structure on state space \mathcal{P} and, therefore, yield a soundness and completeness theorem for Adams’ logic of flat conditionals (which includes Cautious Monotonicity) that is simpler than more natural than Adams’ original version (1975).

4 Geologic

Consider classical, infinitary propositional logic, which allows for countable disjunction and conjunction.⁷ Start with propositional constants \perp, \top and propositional variables $V_\kappa = \{E_i : i \in I\}$, where the countable index set I has cardinality κ . Let $\bigvee_j \phi_j$ and $\bigwedge_j \phi_j$ be countable disjunction and conjunction, respectively. Let language L_κ be the least set containing the propositional constants in V_κ that is closed under negation, countable disjunction, and countable conjunction. We interpret the propositional variables to be mutually exclusive and exhaustive. Under that restriction, each assignment is an κ -dimensional basis vector e_i . Let \mathcal{B}_κ denote the set of all such vectors. The valuation function for classical logic is definable as follows. In the base case:

$$v_{e_i}(E_j) = e_i \cdot e_j; \quad v_{e_i}(\top) = 1; \quad v_{e_i}(\perp) = 0,$$

where \cdot denotes the vector *inner product* $x \cdot y = \sum_{i \in I} x_i y_i$. In the inductive case:

$$v_{e_i}(\neg\phi) = 1 - v_{e_i}(\phi); \quad v_{e_i}(\bigvee_j \phi_j) = \max_j(v_{e_i}(\phi_j)); \quad v_{e_i}(\bigwedge_j \phi_j) = \min_j(v_{e_i}(\phi_j)).$$

Logical entailment is definable in terms of valuation as follows:

$$\phi \models \psi \iff v_{e_i}(\phi) \leq v_{e_i}(\psi), \text{ for all } i \in I.$$

Let the *proposition* $\llbracket \phi \rrbracket_\kappa$ expressed by ϕ in language L_κ denote the set of all assignments in \mathcal{B}_κ in which ϕ evaluates to 1. Each proposition $\llbracket \phi \rrbracket_\kappa$ is represented uniquely by its *valuation vector*:

$$v_\kappa(\phi) = (v_{e_i}(\phi) : i \in I),$$

⁷For classic studies concerning completeness infinitary logic, cf. Karp (1964) and Barwise (1969). Our applications make no reference to completeness or to proof systems for infinitary logic.

which belongs to 2^κ . Define the following relations and operations over 2^κ :

$$u \leq v \iff u_i \leq v_i, \text{ for all } i \text{ in } I; \quad (14)$$

$$(\neg v)_i = 1 - v_i; \quad (15)$$

$$\left(\bigvee_j v^j\right)_i = \max_j v_i^j; \quad (16)$$

$$\left(\bigwedge_j v^j\right)_i = \min_j v_i^j. \quad (17)$$

Then the structure of classical, infinitary logic is captured⁸ by the mathematical structure:

$$\mathcal{L}_\kappa = (2^\kappa, \leq, \bigvee, \bigwedge, 1, 0).$$

Figure 6.a illustrates \mathcal{L}_3 , which bears a suggestive resemblance to the unit cube $[0, 1]^3$

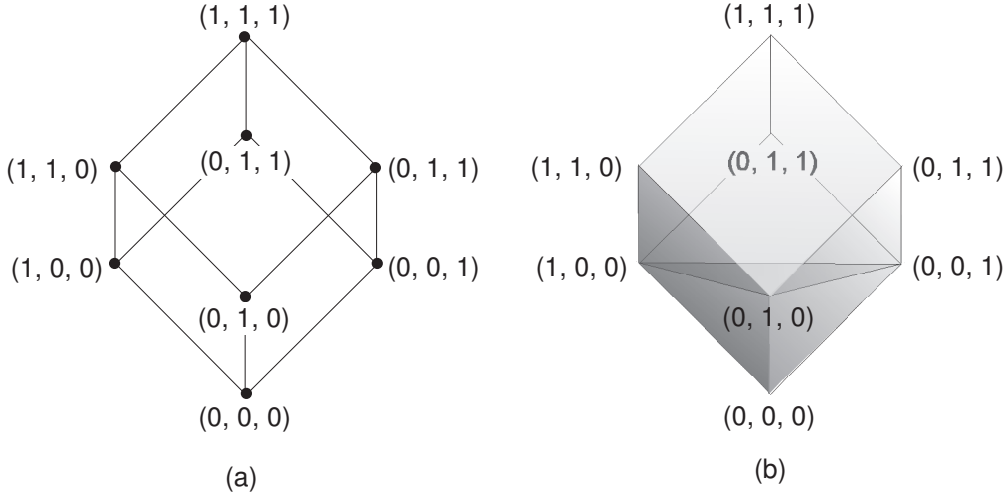

Figure 6: bead-and-string logic vs. geologic

(figure 6.b), but it is really just a string-and-bead figure whose strings happen to be sized and stretched to outline a cube. However, one can *extend* classical propositional logic on L_κ to a *fuzzy* language L_κ^* that generates fuzzy propositions covering the entire κ -dimensional unit cube $[0, 1]^\kappa$.⁹ A *fuzzy proposition* is just a *fuzzy subset* (Zadeh 1965)

⁸I.e., the Lindenbaum-Tarski algebra of language L_κ is isomorphic to \mathcal{L}_κ .

⁹The idea may sound similar to multi-valued logic, but it is quite different. In multi-valued logic, (discrete) logical formulas in L_κ are interpreted over an expanded, continuous space of assignments (Hayek 1998, Novak et al., 2000)—such logics generate a discrete, weakening of classical logic, rather than a continuous, conservative extension of classical logic.

of \mathcal{B}_κ , which is representable by a *fuzzy characteristic function* from \mathcal{B}_κ to $[0, 1]$ and, hence, by a *fuzzy valuation vector* v in $[0, 1]^\kappa$. Formula (14) represents the fuzzy subset relation and formulas (15) through (17) correspond to fuzzy complement, intersection, and union over fuzzy propositions.

Here is one natural way to extend classical logic over L_κ to cover the κ -dimensional unit cube. For each real number d in the unit interval, let the *partial negation* $\neg_d \phi$ be understood as the negation of ϕ to *degree* d , interpreted as follows:

$$v_{e_i}(\neg_d \phi) = d v_{e_i}(\neg \phi) + (1 - d)v_{e_i}(\phi).$$

In particular, $\neg_0 \phi$ is equivalent to ϕ , whereas $\neg_1 \phi$ is equivalent to $\neg \phi$. Between these extremes, $\neg_{1/2} \phi$ hovers semantically midway between ϕ and $\neg \phi$. Let L_κ^* be the result of expanding language L_κ with \neg_d . Otherwise, the preceding definitions of valuation function v_{e_i} and valuation vector $(v_{e_i}(\phi) : i \in I)$ remain unaltered.¹⁰ Partial negation never generates values outside of the unit interval, so all valuation vectors for L_κ^* are in the unit cube $[0, 1]^\kappa$. Conversely, every vector v in $[0, 1]^\kappa$ is the valuation vector of some formula in L_κ^* , namely:

$$\bigvee_{i \in I} (\neg_{1-v_i} E_i \wedge E_i).$$

So the propositions expressible by the fuzzy language \mathcal{L}_κ^* correspond to the vectors in the κ -dimensional unit cube $[0, 1]^\kappa$. Therefore, we refer to the logic just defined as *geologic*.

Formulas (14) to (17) still make sense for fuzzy valuation functions (because they correspond to the standard definitions of the fuzzy set theoretic operations). Therefore, the *structure* of geologic is:

$$\mathcal{L}_\kappa^* = ([0, 1]^\kappa, \leq, \bigvee, \bigwedge, 1, 0).$$

Since the valuation definition for geologic is exactly the same as for classical logic over the fragment L_κ , it follows that \mathcal{L}_κ^* restricted to L_κ is just \mathcal{L}_κ —in other words, geologic is a conservative extension of classical, infinitary logic.

Since the operations in \mathcal{L}_κ^* correspond to fuzzy set theoretical operations on propositions, it is immediate that the geological operations satisfy associativity, commutativity, distributivity, and the De Morgan rules (Zadeh 1965). Excluded middle and disjunctive syllogism, on the other hand, can fail spectacularly for propositions in the unit cube's interior. For example, let c denote the center $(\frac{1}{2}, \dots, \frac{1}{2}, \dots)$ of the unit cube. Then:

$$\begin{aligned} \neg c &= c; \\ c \vee \neg c &= c; \\ (e_1 \vee c) \wedge \neg c &= c. \end{aligned}$$

¹⁰More directly, one can simply introduce a new unary connective $a\phi$ called *scalar multiple* interpreted by $v_{e_i}(a\phi) = a v_{e_i}(\phi)$. But we found it harder to motivate usage of such a connective.

In spite of that, we think of geologic as the natural *extension* of classical logic to fuzzy propositions. Associativity, commutativity, distributivity, and the De Morgan rules are all motivated by symmetries of the unit cube. Excluded middle is not motivated by symmetry—it is a mere artifact of an impoverished syntax. Furthermore, unlike modal logic, which is also a conservative extension of classical propositional logic, geologic arises from the addition of a *truth-functional* negation.

Filling the interior of the Boolean algebra to make it a genuine cube provides an explanatory, geometrical perspective on classical logic. For example, given points v and u in the unit cube, find the smallest parallelepiped solid $S(v, u)$ containing v and u whose sides are parallel to the sides of the cube. Then the uppermost vertex of $S(v, u)$ is $v \vee u$ and the lowermost vertex of $S(v, u)$ is $v \wedge u$ (figure 7.a). The parallelepiped $S(v, u)$ is like a sub-crystal within the cube, which is another reason for thinking of geologic as *geological*.¹¹ The geometry of full geological negation is just reflection through the

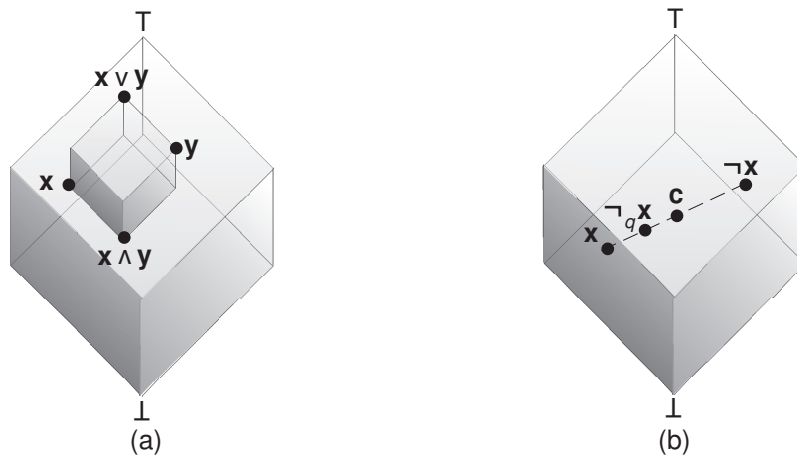

Figure 7: geological operations

center c of the cube, which is a natural generalization of Boolean complementation. To construct the partial negation $\neg_d v$ of v , first reflect v through c to obtain the full negation $\neg v$. Now draw a straight line segment between v and $\neg v$. Then $\neg_d v$ is the point that lies proportion d of the way from v to $\neg v$ along the line segment (figure 7.b). Consider the classical De Morgan rules. Since full negation involves projection through the center c of the cube, think of c as the aperture of a pinhole camera. It is a familiar fact that projection through an aperture inverts the image. But the disjunction $v \vee u$ is the top vertex of the parallelepiped spanning v and u . Projecting the parallelepiped

¹¹Note that the same geometrical relationships would hold even if the unit cube were stretched along its various axes to form a prism. We will return to that theme in the last section of the paper.

through the aperture inverts it and turns the top vertex into the bottom vertex—the conjunction of the projection of v with the projection of u (figure 8).

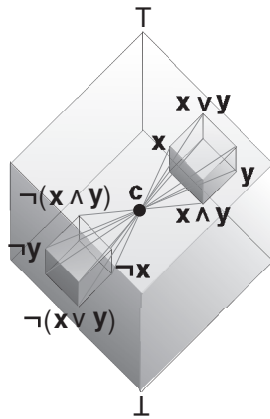

Figure 8: geometry of the De Morgan Rules

5 Logic from a Probabilistic Perspective

For our purposes, the point of geologic is that it affords a unified perspective on logic and probability.¹² The set \mathcal{P}_3 of possible credal states is a horizontal, triangular plane through the unit cube of geological propositions (figure 6.b). Thus, credal state space \mathcal{P}_3 has a natural embedding *within* geologic. That embedding generalizes to each countable cardinality κ .

Valuation and probability assignment can both be viewed as inner products within the geological cube:

$$\begin{aligned} v_{e_i}(u) &= e_i \cdot u, \\ p(b) &= p \cdot b,^{13} \end{aligned}$$

where u is a vector in $[0, 1]^\kappa$ corresponding to an arbitrary, geological proposition, v_{e_i} is a valuation function corresponding to a classical assignment, b is a Boolean valuation vector in 2^κ corresponding to a classical proposition, and p is a probability measure/vector in \mathcal{P}_κ .

Say that probability measure p is *uniform* with respect to \mathcal{E} if and only if p assigns only zero or a fixed value to the answers in \mathcal{E} . The *support* of p is the disjunction of

¹²Due to the truth-functionality of conjunction in fuzzy logic, the fuzzy logic community tends to view fuzzy logic in isolation from probability theory, rather than as a tool for understanding probability theory, as we propose.

all elements of \mathcal{E} that p assigns non-zero probability to (recall that \mathcal{E} is countable). The *classical principle of indifference* is a mapping σ that associates each uniform probability distribution p with its support. For example, σ associates $(\frac{1}{2}, \frac{1}{2}, 0)$ with the classical proposition $\sigma(\frac{1}{2}, \frac{1}{2}, 0) = (1, 1, 0)$. Construct a ray from \perp through uniform distribution p and then $\sigma(p)$ is the (classical) proposition on the upper surface of the unit cube that the ray points to (figure 9.a). Algebraically, $\sigma(p)$ is the (unique) scalar

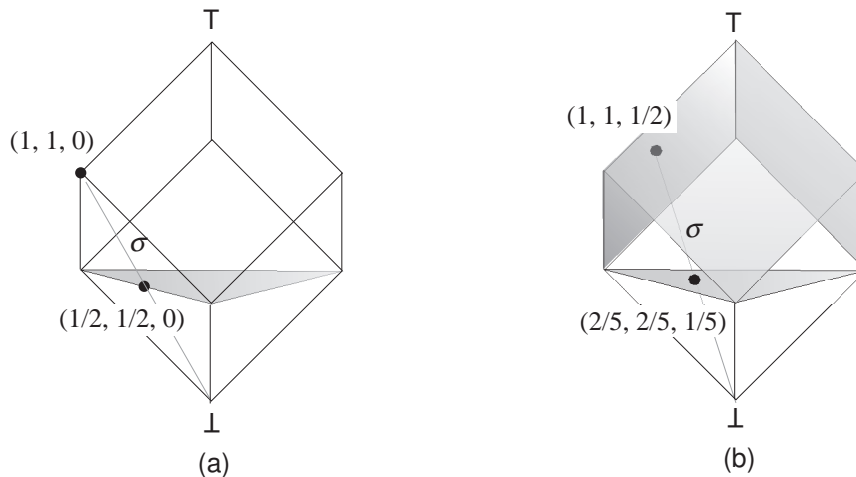

Figure 9: indifference as projection

multiple of p in the unit cube that has at least one component equal to 1, which amounts to the formula encountered earlier in the definition of the symmetric camera shutter acceptance rules:

$$\sigma(p)_i = \frac{p_i}{\max_j p_j}, \text{ for } i \in I.$$

Say that geological proposition u is *fully satisfiable* if and only if there exists e_i such that $v_{e_i}(u) = 1$, i.e. u has a component equal to 1. So $\sigma(p)$ is the (unique), fully satisfiable, geological valuation vector that is proportional to p . In classical logic, the mapping $\sigma(p)$ is defined only for uniform p , but it is defined for *all* p in geologic, since the (continuous) upper surface of the geological cube covers the entire triangle of probability measures (figure 9.b). Now *every* probability measure p has a unique, geological proposition $\sigma(p)$ that stands to p in much the same way that the support of p stands to uniform p .

Mapping σ has a heuristic interpretation. Think of the unit cube as a room with tiled walls (figure 10). Imagine that there is a digital camera embedded in the baseboard of the room at corner \perp . Think of the triangle \mathcal{P}_3 as the picture plane corresponding to the 2-dimensional image received by the camera. Then the inverse σ^{-1} of σ is

the classical perspective rendering of the room’s interior on the picture plane. The perspective is extreme because the camera is literally embedded in the lower corner of the room, so the floor and adjacent walls are tangent to the camera’s view and are rendered as the boundaries of the triangular picture.

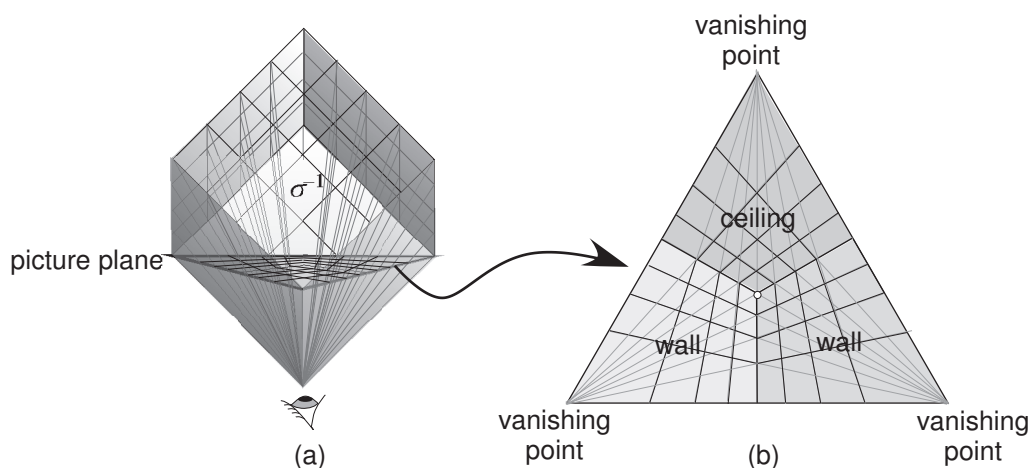

Figure 10: a literal, probabilistic perspective on logic

The point of the preceding detour through geologic is that the picture plane is the space \mathcal{P}_3 of probability measures on \mathcal{A}_3 and the walls and ceiling of the office are the fully satisfiable propositions in geologic. So figure 10 literally illustrates geologic from a *probabilistic perspective*. That perspective sheds new light on the lottery paradox and its associated conundrums. In particular, note the similarity between the acceptance zones of the proposed, paradox-avoiding rule (figure 4) and the projected coordinate lines of the unit cube (figure 10.b). The boundaries of the former always follow the latter.

6 Probalogic

We understand “logic” in the broad, pragmatic sense that logic is wherever logical structure is. If the logical structure pertains to relative strength of credal states, then there is a logic of such states, even though the states in question are not necessarily propositional and the logical relations among them are not plausibly interpreted as arguments. And if the structure happens to be relative to pragmatic factors such as a question that elevates the significance of certain propositions as relevant answers, then logic, itself, is pragmatic—we do not insist that logic must in some sense be prior to or independent of such considerations. Our view accords with an ancient tradition

according to which logic is a tool or organon for *inquiry*, which typically begins with some question and ends with an answer thereto. In this section, we introduce a logic of probabilistic credal states in the broad, pragmatic sense just outlined.

When credence is modeled as qualitative belief in a proposition, it is straightforward to judge the relative strength of credal states in terms of the classical, logical strength of the propositions believed:

$$B\phi \leq B\psi \iff \phi \leq \psi.$$

We propose, in a similar spirit, that probabilistic credal states inherit their logical strength from their unique, geological images:

$$p \leq q \iff \sigma(p) \leq \sigma(q) \tag{18}$$

$$\iff \sigma(p)_i \leq \sigma(q)_i \text{ for all } i \in I. \tag{19}$$

Disjunction \vee and conjunction \wedge are standardly defined, respectively, as the least upper bound and the greatest lower bound with respect to \leq . We call the resulting logical structure on probability measures *probalogic*:

$$(\mathcal{P}, \leq, \vee, \wedge).$$

Probalogic is just geologic from a probabilistic perspective.

Consider arbitrary credal state p in \mathcal{P}_3 . Which credal states are probalogically at least as weak as p ? First, project p up to geological proposition $\sigma(p)$ on the upper surface of the geological cube. The geological consequences of $\sigma(p)$ consist of the parallelepiped containing \top whose sides are parallel to the sides of the unit cube and whose bottom-most corner is $\sigma(p)$ (figure 11). Since $\sigma(p)$ is incident to an upper surface of the cube, the parallelepiped is, in this case, a rectangle lying entirely in one upper face of the unit cube (or, in degenerate cases, entirely within an upper edge of the unit cube). The probalogical consequences of p are contained within the linear perspective projection of that rectangle onto the picture plane \mathcal{P}_3 . Note that, according to the usual rules of linear perspective, parallel sides of the rectangles meet at *vanishing points*, which correspond to the corners of \mathcal{P}_3 that are not closest to p . Similarly, the geological propositions in the range of σ that are geologically at least as strong as $\sigma(p)$ are in the rectangle with sides parallel to the sides of the unit cube that has $\sigma(p)$ as its upper corner and the nearest unit vector e_i to $\sigma(p)$ as its lower corner. So the inverse image of that rectangle under σ is the set of the credal states that are probalogically at least as strong as $\sigma(p)$. We call the partial order \leq so defined *relative probalogical strength*.

Probalogical disjunction, conjunction, and negation can be defined similarly, as the

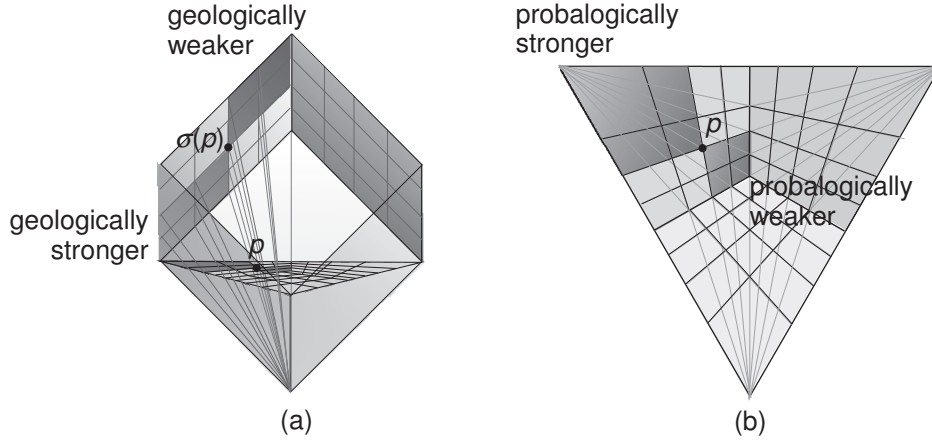

Figure 11: probalogical strength

projections of the corresponding, geological disjunction:

$$p \vee q = \sigma^{-1}(\sigma(p) \vee \sigma(q)); \quad (20)$$

$$p \wedge q = \sigma^{-1}(\sigma(p) \wedge \sigma(q)); \quad (21)$$

$$\neg p = \sigma^{-1}(\neg\sigma(p)). \quad (22)$$

Since the geological disjunction of two propositions on the upper surface of the unit cube is also on the upper surface of the unit cube, \mathcal{P}_3 is closed under probalogical disjunction. Geometrically, these logical operations can be constructed as perspective renderings of the corresponding geological operations on the cube (figures 12, 13, and 14). Probalogical constants and operations are not necessarily defined. In finite questions, \top denotes the uniform distribution, but in countably infinite questions there is no such distribution. There is no interpretation of \perp . Letting $\perp = \top$ is obvious unappealing, but any choice of \perp that is off-center is equally implausible. Geological negation is closed over the lower edges of the upper faces of the unit cube, but is not closed elsewhere over the upper faces of the unit cube, so probalogical negation is defined only over the lower edges of the unit cube. Furthermore, if $\sigma(p)$ and $\sigma(q)$ are on different upper faces of the unit cube, then the conjunction $\sigma(p) \wedge \sigma(q)$ lies below the upper faces of the unit cube, so $p \wedge q = \sigma^{-1}(\sigma(p) \wedge \sigma(q))$ is undefined.

Although we will not pursue the idea in this paper, there is a way to expand \mathcal{P} to a space over which probalogical conjunction and disjunction are closed. Some assumptions are so certain that one does not even conceive of their falsity—e.g., that a particle cannot have two distinct momenta at the same time but can have a definite momentum and position at the same time. But when experience gets strange, we may come to doubt our basic assumptions without having thought yet of any concrete

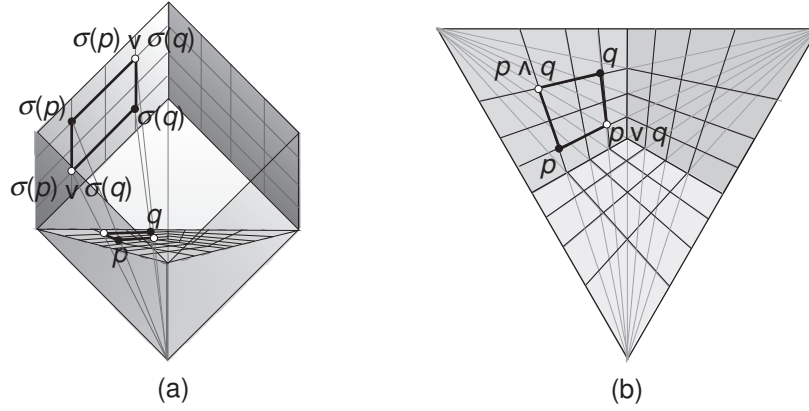

Figure 12: probological conjunction and disjunction within a face

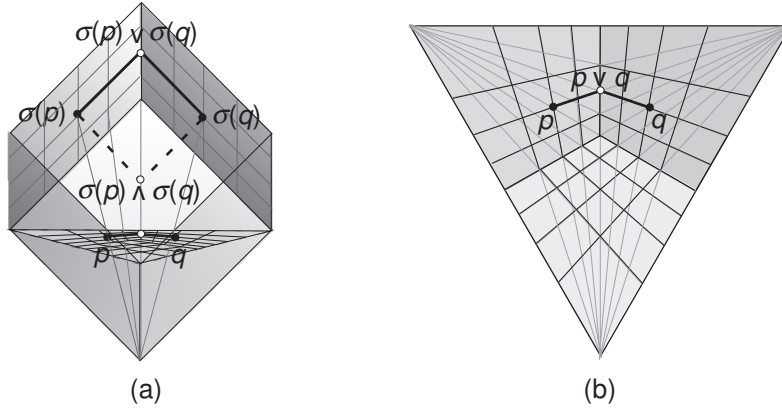

Figure 13: probological conjunction and disjunction across faces

alternatives. In such cases, a natural response is to transfer probability mass to a non-descript “catchall hypothesis” absent from the original algebra \mathcal{A}_3 . Within \mathcal{A}_3 , the resulting credal state appears to be normalized to a value less than 1. Accordingly, let \mathcal{P}^* denote the set of all additive measures p on \mathcal{A} such that $0 \leq p(\top) \leq 1$. Then the problem of closure under negation and conjunction is solved by plausibly *extending* σ to a bijection between \mathcal{P}^* and the entire unit cube as follows (figure 15):

$$\sigma^*(p)_i = p(\top) \cdot \frac{p_i}{\max_j p_j}, \text{ for } i \in I.$$

So equations (18) to (22), with σ replaced by σ^* , induce a probological structure on \mathcal{P}^* that is closed under the probological operations of conjunction, disjunction, and negation.

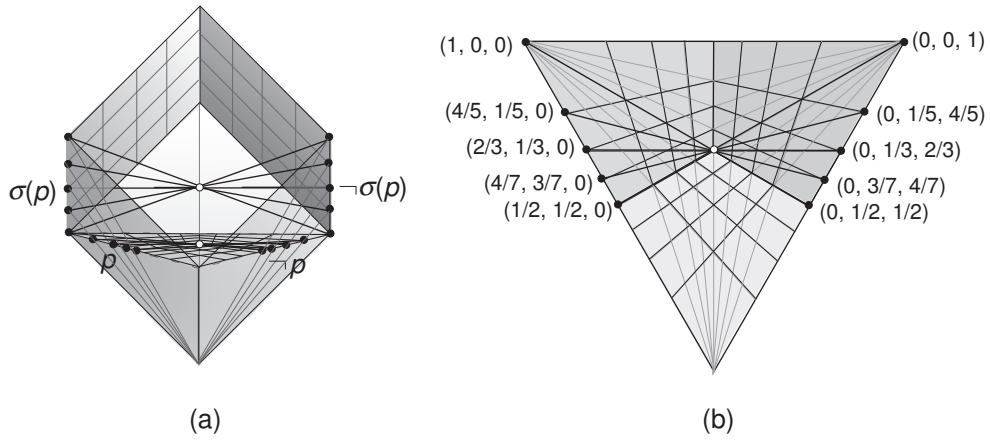

Figure 14: negation around the perimeter

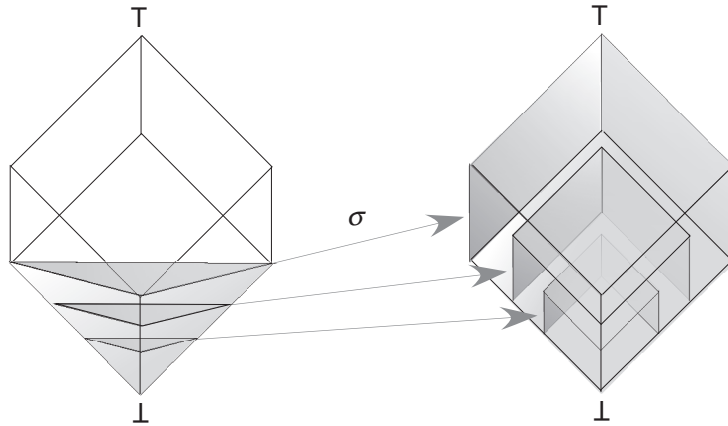

Figure 15: σ extended to measures normalized to a value ≤ 1

7 Acceptance that Respects Probalogic

A *probalogical* acceptance rule ν is an acceptance rule that preserves probalogical structure in the sense of morphism conditions (5) to (8).¹⁴ As described in the preceding section, condition (7) is understood to hold only when $p \wedge q$ is defined over \mathcal{P} .

Recall the camera-shutter-like acceptance rules introduced above as one geometrical strategy for solving the lottery paradox. The rules can be stated a bit more generally, by allowing the threshold r and the strictness of the inequality to vary with i . Say that

¹⁴Note that (5) is redundant, for it is derivable from (6).

acceptance rule ν is a *camera shutter rule* for \mathcal{E} if and only if there exist thresholds $\{r_i : i \in I\}$ in the unit interval and inequalities $\{\triangleleft_i : i \in I\}$ that are either \leq or $<$, such that for each p in \mathcal{P} and $i \in I$:

1. $\nu(p) = \bigwedge \{\neg E_i : \sigma(p)_i \triangleleft_i 1 - r_i \text{ and } i \in I\}$;
2. if $\triangleleft_i = \leq$ then $r_i > 0$;
3. if $\triangleleft_i = <$ then $r_i < 1$.

Note that 0 is omitted in the second condition to make it possible to not accept $\neg E_i$, and 1 is omitted in the third condition to make it possible to accept $\neg E_i$ —else morphism condition (8) would be violated trivially. The main result of this section is that, over countable dimensions, the camera shutter rules are precisely the rules that preserve probalogic.

Theorem 1 (representation of probalogical rules). *Suppose that \mathcal{E} is countable. Then an arbitrary acceptance rule is probalogical if and only if it is a camera shutter rule.*

The proof proceeds by a series of lemmas. Let p, q be in \mathcal{P} . Define:

$$q \leq_i p \iff \sigma(p)_i \leq \sigma(q)_i.$$

Lemma 1. *Suppose that $q \leq_i p$. Then $p = (p \vee e_i) \wedge (p \vee q)$.*

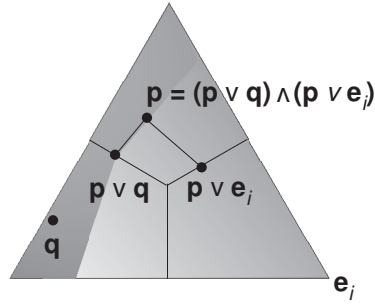

Figure 16: proof of lemma 1

Proof. See figure 16. By the definition of probalogic in terms of geologic, it suffices to show that

$$\sigma(p) = \sigma((p \vee e_i) \wedge (p \vee q)).$$

By geologic, the j -th component of the right hand side expands to:

$$\min(\max(\sigma(p)_j, \sigma(e_i)_j), \max(\sigma(p)_j, \sigma(q)_j)).$$

Since $(e_i)_i = 1$, it follows that $\max(\sigma(p)_i, \sigma(e_i)_i) = 1$. Since $\sigma(q)_i \leq \sigma(p)_i$, it follows that $\max(\sigma(p)_i, \sigma(q)_i) = \sigma(p)_i$. So $\sigma((p \vee e_i) \wedge (p \vee q))_i = \sigma(p)_i$. Now let E_j be in \mathcal{E} for $j \neq i$. Then $(e_i)_j = 0$, so $\max(\sigma(p)_j, \sigma(e_i)_j) = \sigma(p)_j$. In general, $\min(x, \max(x, y)) = x$, so we have as well that $\sigma((p \vee e_i) \wedge (p \vee q))_j = \sigma(p)_j$. \square

Lemma 2. *Let ν satisfy morphism conditions (6), (7), and (8). Let $i \in I$. Then:*

$$p \Vdash_\nu \neg E_i \text{ and } q \leq_i p \implies q \Vdash_\nu \neg E_i.$$

Proof. Suppose that $p \Vdash_\nu \neg E_i$ and that $q \leq_i p$. Since $p \Vdash_\nu \neg E_i$, it follows that $p_i < \max_k p_k$. For otherwise, $e_i \leq p$, so by morphism condition 5, $e_i \Vdash_\nu \neg E_i$, contrary to morphism condition (8). Since it is also the case that $q \leq_i p$, lemma 1 yields that $p = (p \vee e_i) \wedge (p \vee q)$. Suppose for reductio that $\nu(q)$ is logically compatible with E_i . Then by morphism condition (6), $\nu(p \vee q)$ is compatible with E_i . By morphism condition (8), $\nu(e_i)$ is compatible with E_i . So again by morphism condition (6), $\nu(p \vee e_i)$ is compatible with E_i . So $\nu(p) = \nu((p \vee e_i) \wedge (p \vee q))$ is compatible with E_i , by morphism condition (7) and by the fact that E_i is an atom in algebra \mathcal{A} . But $p \Vdash_\nu \neg E_i$. Contradiction. Hence, $q \Vdash_\nu \neg E_i$. \square

Proof of theorem 1. For the only if side, let $i \in I$. Define:

$$1 - r_i = \sup\{\sigma(p)_i : p \in \mathcal{P} \text{ and } p \Vdash_\nu \neg E_i\}.$$

Suppose that $\sigma(p)_i <_i 1 - r_i$. Then $p \Vdash_\nu \neg E_i$, by lemma 2. Suppose that $\sigma(p)_i > 1 - r_i$. Then $p \not\Vdash_\nu \neg E_i$, by the definition of $1 - r_i$. Finally, suppose that $\sigma(p)_i = \sigma(q)_i = 1 - r_i$. Consider the case in which there exists r in \mathcal{P} such that $\sigma(r) = 1 - r_i$ and $r \Vdash_\nu \neg E_i$. Then $p \Vdash_\nu \neg E$ and $q \Vdash_\nu \neg E$, by lemma 2. In the alternative case, it is immediate that $p \not\Vdash_\nu \neg E$ and $q \not\Vdash_\nu \neg E$. Thus, $p \Vdash_\nu \neg E_i$ if and only if $q \Vdash_\nu \neg E_i$. Set $\triangleleft_i = \leq$ in the former case and set $\triangleleft_i = <$ in the latter case. In the former case, suppose for reductio that $r_i = 0$. Then $\nu(e_i) \Vdash_\nu \neg E_i$, contradicting morphism condition (8), so $r_i > 0$, as required. In the latter case, suppose for reductio that $r_i = 1$. Then $\nu(e_i) \not\Vdash_\nu E_i$, contradicting morphism condition (8), so $r_i > 0$, as required. For the if side of the theorem, suppose that ν is a camera shutter rule for countable \mathcal{E} . For morphism condition (5), suppose that $p \leq q$. Then $\sigma(p)_i \leq \sigma(q)_i$, for each $i \in I$. Then $q \Vdash_\nu E_i$ implies $p \Vdash_\nu E_i$, so $\nu(p) \leq \nu(q)$. For morphism condition (6), let $\nu(p) = A$ and $\nu(q) = B$, so:

$$\begin{aligned} A &= \bigwedge \{\neg E_i : \sigma(p)_i \triangleleft_i 1 - r_i\}; \\ B &= \bigwedge \{\neg E_i : \sigma(q)_i \triangleleft_i 1 - r_i\}. \end{aligned}$$

Let $\mathcal{D} = \{\neg E_i : A \leq E_i \text{ and } B \leq E_i\}$ and note that $A \vee B = \bigwedge \mathcal{D}$. Suppose that $\neg E_i$ is in \mathcal{D} . Then $\sigma(p)_i \triangleleft_i 1 - r_i$ and $\sigma(q)_i \triangleleft_i 1 - r_i$. Hence, $\max(\sigma(p)_i, \sigma(q)_i) \triangleleft_i 1 - r_i$. Thus, $\nu(p \wedge q) \leq \neg E_i$. Suppose that $\neg E_i$ is not in \mathcal{D} . Then either $\sigma(p)_i \not\triangleleft_i 1 - r_i$ or $\sigma(q)_i \not\triangleleft_i 1 - r_i$, so $\max(\sigma(p)_i, \sigma(q)_i) \not\triangleleft_i 1 - r_i$ and, thus, $\nu(p \wedge q) \not\leq \neg E_i$. Hence, $\neg E_i$ is in \mathcal{D} if and only if $\nu(p \wedge q) \leq \neg E_i$. Therefore, $\nu(p \vee q) = \bigwedge \mathcal{D} = A \vee B$. The dual argument works for morphism condition (7). \square

Recall that the conditions (5)-(7) omit preservation of negation and of the infinitary versions of disjunction and conjunction. There are good reasons to drop those conditions.

Proposition 4. *In finite dimensions, no probalogical acceptance rule preserves infinite conjunction and disjunction.*

Proof. Consider probalogical acceptance rule ν for question $\{E_i : i \in I\}$. By morphism condition (8), $\nu(e_1) = E_1$ and $\nu(e_2) = E_2$. Let L be the straight line connecting e_1 with e_2 . Note that no uniform distribution with infinite support is encountered along this line, so it is continuous. So by morphism condition (5), there is a boundary point b such that $q \Vdash_\nu E_1$, for all q closer to e_1 than b , and $q \not\Vdash_\nu E_1$, for all q farther from e_1 than b . Let m be the mid-point of L . Consider the case in which p is between m and e_1 . Consider the case in which $b \Vdash_\nu E_1$. Let $\{p_i : i \in \mathbb{N}\}$ be a discrete sequence of points in line segment $\overline{e_1 b}$ that converges to b and let $\{q_i : i \in \mathbb{N}\}$ be a discrete sequence of points in line segment $\overline{m b}$ that converges to b . Then:

$$\bigvee_i p_i = b = \bigwedge_i q_i.$$

Suppose that $b \not\Vdash_\nu E_1$. Then $\nu(\bigvee_i p_i) \neq \bigvee_i \nu(p_i)$. Alternatively, suppose that $b \Vdash_\nu E_1$. Then $\nu(\bigwedge_i q_i) \neq \bigwedge_i \nu(q_i)$. \square

Proposition 5. *In finite dimensions, no probalogical acceptance rule also preserves probalogical negation.*

Proof. Let $p = (\frac{2}{3}, \frac{1}{3}, 0)$. Assume, for reductio, that acceptance rule ν is probalogical and preserves probalogical negation as well. So by proposition 1, ν is a camera shutter rule. Suppose that ν rejects E_2 in p . So $\sigma(e_2) = \frac{1}{2} \triangleleft_2 1 - r_2$. Note, in figure 14, that $\neg p = (0, \frac{1}{3}, \frac{2}{3})$. So by preservation of negation, ν does not reject E_2 at $\neg p$. Thus: $\sigma(e_2) = \frac{1}{2} \not\triangleleft_2 1 - r_2$, which is a contradiction. The case in which ν does not reject E_2 in p is similar. The argument generalizes to arbitrary, finite dimensions. \square

On the other hand, setting each $r_i = \frac{1}{2}$ *almost* preserves negation, in the sense that negation is preserved at all points on the perimeter of the triangle *except* at the six probability assignments with range $\{0, \frac{1}{3}, \frac{2}{3}\}$. But even so, no other setting for the r_i

other than $\frac{1}{2}$ has that property, so the demands imposed by negation preservation are unreasonably strict.

8 Acceptance that Does Not Respect Probalogic

The acceptance rules we recommend, the camera shutter rules, are exactly the rules that preserve probalogical structure. Alternative acceptance rules proposed by Kyburg (1961) and by Pollock (1995) fail to preserve probalogical structure—actually, they fail to preserve any plausible logical structure.

Each Kyburgian acceptance rule χ_r is a Lockean rule without closure under conjunction:

$$\chi_r = \{A \in \mathcal{A} : p(A) \geq r\}.$$

Let question \mathcal{E} be ternary and set $r = \frac{2}{3}$. In figure 17, the set $\chi_{\frac{2}{3}}(c)$ of propositions accepted at the center $c = (\frac{1}{3}, \frac{1}{3}, \frac{1}{3})$ is indicated by a solid line and the set $\chi_{\frac{2}{3}}(e_3)$ is indicated by a dashed line. Rule $\chi_{\frac{2}{3}}$ does not preserve logical order in any plausible

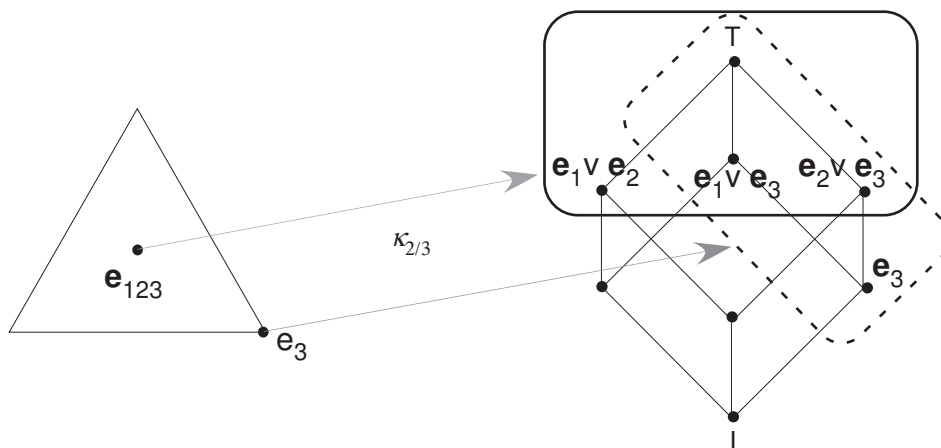

Figure 17: Kyburgian acceptance rule

sense, for corner e_3 is at least as strong as center c , but $\chi_{\frac{2}{3}}(e_3)$ is, intuitively, not at least as strong as $\chi_{\frac{2}{3}}(c)$ due to the retraction of $e_1 \vee e_2$.

There is, therefore, a hidden dilemma in Kyburg's thesis that one should give up closure of accepted propositions under conjunction. On the one hand, if only \top is accepted at the uniform measure c , then there is no lottery paradox and, hence, there is no motivation for failing to close the accepted propositions under conjunction. On

the other hand, if some proposition other than \top is accepted at c —say, a disjunction D that is incompatible with E_i —then, using the same argument as above, when one jumps from the center c to the stronger state e_i , one must accept E_i (which has probability one) and retract D (which has probability zero) and thus one must fail to expand the set of accepted propositions. In contrast, all camera shutter rules preserve probabilistic logic.

Pollock (1995), Ryan (1996), and Douven (2002) all propose variants of the Lockean acceptance rule, which we will call *Pollockian*. The basic idea is to *restrict* the Lockean rule to cases in which it produces no paradox. The idea is illustrated, for ternary \mathcal{E} , in figure 18. The basic difference between Pollockian and Lockean rules in 3-dimension

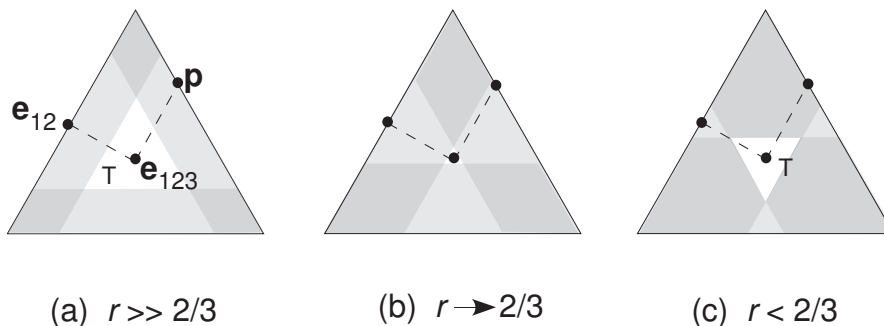

Figure 18: Pollockian acceptance rules

is that the former return \top whenever the latter return \perp (compare to figure 3). The choice of \top as a substitute for \perp is natural enough, on grounds of symmetry, but due to the *shape* of Pollockian acceptance zones, there still exists no single logical structure that all Pollockian rules preserve.

Proposition 6. *Suppose that \mathcal{E} is ternary. Let \preceq be an arbitrary partial order on \mathcal{P} whose binary least upper bound operation Υ is totally defined. Then there exists at least one Pollockian acceptance rule that is not a structure preserving map from $(\mathcal{P}_3, \preceq, \Upsilon)$ to $(\mathcal{A}_3, \leq, \vee)$.*

Proof. Suppose the contrary for reductio. Let π_r be a Pollockian rule. When $r > \frac{2}{3}$, as in figure 18.a, the rule π_r accepts $E_1 \vee E_2$ at $p = (\frac{1}{2}, \frac{1}{2}, 0)$ and $E_2 \vee E_3$ at $q = (0, \frac{2}{3}, \frac{1}{3})$, respectively, whose disjunction is $E_1 \vee E_2 \vee E_3 = \top$. So, to preserve disjunction, $p \Upsilon q$ must lie within the white triangle, where \top is accepted. If we let r approach $\frac{2}{3}$ from above, as in figure 18.b, the white triangle converges to the center point $c = (\frac{1}{3}, \frac{1}{3}, \frac{1}{3})$, so $p \Upsilon q = c$. Now consider the case in which $r < \frac{2}{3}$ (figure 18.c). By preservation of

disjunction, we have:

$$\begin{aligned}
\top &= \pi_r(c) \\
&= \pi_r(p \vee q) \\
&= \pi_r(p) \vee \pi_r(q) \\
&= (E_1 \vee E_2) \vee E_2 \\
&= E_1 \vee E_2.
\end{aligned}$$

Hence $\top = E_1 \vee E_2$, a contradiction. \square

A dilemma for Pollockian theorists is that, on the one hand, symmetry precludes accepting anything other than \top at the center point c , but that implies that there is no logical structure on \mathcal{P} that all Pollockian rules preserve. In contrast, all camera shutter rules preserve probalogic.

9 The Geometry of Nonmonotonic Reasoning

As illustrated in figure 5, acceptance zones with the wrong shape can invalidate plausible principles of nonmonotonic reasoning. In fact, each axiom of nonmonotonic logic corresponds to a definite, geometrical constraint on acceptance zones. The correspondences are established in this section and are used below to demonstrate that each probalogical rule validates a plausible set of axioms for nonmonotonic logic known as system P.

A (*nonmonotonic*) *consequence relation* on the set \mathcal{A} of propositions is a binary relation on \mathcal{A} denoted by \vdash with suitable subscripts, where $A \vdash B$ is intended to mean that one would accept B given information A . The following axioms for consequence relations, referred to as *system P*, have been recognized as central both to nonmonotonic consequence (Kraus, Lehmann, and Magidor 1990) and to acceptance of flat conditionals (Adams 1975):¹⁵

$$\begin{array}{l}
\text{(Reflexivity)} \quad \frac{}{A \vdash A} \\
\text{(And)} \quad \frac{A \vdash B \quad A \vdash C}{A \vdash B \wedge C} \\
\text{(Left Equivalence)} \quad \frac{A \vdash B}{A' \vdash B} \text{ if } A \text{ is classically equivalent to } A'.
\end{array}$$

¹⁵In the nonmonotonic logic literature, conditional axioms governing the consequence relation are written like inference rules. Think of the horizontal line as material implication.

(**Right Weakening**) $\frac{A \vdash B}{A \vdash B'}$ if B classically entails B' .

(**Cautious Monotonicity**) $\frac{A \vdash B \quad A \vdash C}{A \wedge B \vdash C}$ (**Or**) $\frac{A \vdash C \quad B \vdash C}{A \vee B \vdash C}$

Each acceptance rule α and credal state p naturally determine a consequence relation, as defined earlier in terms of probabilistic conditioning (13):

$$A \vdash_{\alpha,p} B \iff p(\cdot|A) \Vdash_{\alpha} B \text{ or } p(A) = 0.$$

Say that acceptance rule α *validates* an axiom for consequence relations if and only if that axiom is satisfied by consequence relation $\vdash_{\alpha,p}$ for all credal states p in the domain of α . Say that α *validates* a set of axioms if and only if α validates each axiom in that set. The first three axioms in system P are validated trivially.

Proposition 7. *Each acceptance rule validates And, Left Equivalence, and Right Weakening.*

Proof. Immediate from the modeling assumption: $\alpha(p)$ is the strongest proposition accepted by rule α at credal state p . \square

Say that rule α *accepts every certain proposition* if and only if for each credal state p in \mathcal{P} and each proposition A in \mathcal{A} that is certain with respect to p (i.e., $p(A) = 1$), we have that $p \Vdash_{\alpha} A$.

Proposition 8. *Let α be an acceptance rule. Then, α validates Reflexivity if and only if α accepts every certain proposition.*

Proof. For the only if side, suppose that $p(A) = 1$. Then we have that $A \vdash_{\alpha,p} A$ (by Reflexivity), and thus that $p(\cdot|A) \Vdash_{\alpha} A$ (because $p(\cdot|A)$ exists), and hence that $p \Vdash_{\alpha} A$ (because $p = p(\cdot|A)$). So α accepts every certain proposition. For the converse, let α be an acceptance rule and p a credal state. Either credal state $p(\cdot|A)$ is undefined, and thus we have that $A \vdash_{\alpha,p} A$ by default; or $p(\cdot|A)$ is defined, and thus $p(A|A) = 1$ and then $p(\cdot|A) \Vdash_{\alpha} A$ (by acceptance of every certain proposition) and hence we have that $A \vdash_{\alpha,p} A$ (by definition). \square

Axioms Cautious Monotonicity and Or impose substantial geometrical constraints on acceptance rules. If A is a proposition in \mathcal{A} , then let $\mathcal{P}|A$ denote the set of all p in \mathcal{P} such that $p(A) = 1$ and say that $\mathcal{P}|A$ is the *facet* of simplex \mathcal{P} for proposition A . The *line segment* with endpoints p, q in simplex \mathcal{P} is defined to be:

$$\overline{pq} = \{ap + (1-a)q : a \in [0, 1]\}.$$
¹⁶

¹⁶Addition is defined as vector addition; multiplication is defined as scalar multiplication.

Say that q is a *projection* of p from facet $\mathcal{P}|\neg A$ onto facet $\mathcal{P}|A$ if and only if (i) q is not a member of the complementary facet $\mathcal{P}|\neg A$ and (ii) there exists a line segment L through p with endpoint q in $\mathcal{P}|A$ and the other endpoint in facet $\mathcal{P}|\neg A$.

Lemma 3. *Credal state q is a projection of p from facet $\mathcal{P}|\neg A$ onto facet $\mathcal{P}|A$ if and only if $p(\cdot|A)$ is defined and $q = p(\cdot|A)$.*

Proof. This lemma is trivially true when p is in $\mathcal{P}|A$ or in $\mathcal{P}|\neg A$, so suppose that p is neither in $\mathcal{P}|A$ nor in $\mathcal{P}|\neg A$ and, thus, that both $p(\cdot|A)$ and $p(\cdot|\neg A)$ are defined. For the if side, consider line segment $L = \overline{p(\cdot|A) p(\cdot|\neg A)}$, whose endpoints are in $\mathcal{P}|A$ and $\mathcal{P}|\neg A$, respectively. Note that p lies on L , since for each B in \mathcal{A} ,

$$p(B) = p(B|A)p(A) + p(B|\neg A)p(\neg A) = ap(B|A) + (1-a)p(B|\neg A),$$

where $a = p(A)$. Therefore, $p(\cdot|A)$ is a projection of p from $\mathcal{P}|\neg A$ onto $\mathcal{P}|A$. For the only if side, suppose that q is a projection of p from facet $\mathcal{P}|\neg A$ onto facet $\mathcal{P}|A$. So q is in $\mathcal{P}|A$ and there exists credal state r in $\mathcal{P}|\neg A$ such that line segment $\overline{q r}$ contains p . Then, p lies in the interior of $\overline{q r}$, since p is neither in $\mathcal{P}|A$ nor in $\mathcal{P}|\neg A$. So there exists a in the open interval $(0, 1)$ such that $p = aq + (1-a)r$. Then it suffices to show that $q = p(\cdot|A)$. Consider the case in which $E_i \not\leq A$. Then $E_i \leq \neg A$. Since q is in facet $\mathcal{P}|A$, we have that $q(E_i) = 0 = p(E_i|A)$. Now consider the case in which $E_i \leq A$. Then since r is in facet $\mathcal{P}|\neg A$, we have that $r(E_i) = 0$, so $p(E_i) = aq(E_i)$. Similarly, we have that $q(A) = 1$ and $r(A) = 0$, so $p(A) = a \cdot 1 + 0 = a$. Hence, $q(E_i) = p(E_i)/a = p(E_i)/p(A) = p(E_i)p(A|E_i)/p(A) = p(E_i|A)$. So $q(\cdot)$ agrees with $p(\cdot|A)$ for all E_i in \mathcal{E} and, thus, for all B in \mathcal{A} , as required. \square

Proposition 9 (geometry of Cautious Monotonicity). *Let α be an acceptance rule. Then, α validates Cautious Monotonicity if and only if the following condition holds: for each credal state p and for each proposition A , if α accepts A at p , then α accepts A at the projection of p on the facet $\mathcal{P}|B$, for each logical consequence B of A (as long as the projection exists); in light of lemma 3, the condition may be restated as:*

$$p \Vdash_{\alpha} A, \quad A \leq B, \quad \text{and } p(\cdot|B) \text{ is defined} \quad \implies \quad p(\cdot|B) \Vdash_{\alpha} A. \quad (23)$$

Proof. The proof of the only if side involves unpacking the definitions and checking that the projection condition (23) is simply an instance of Cautious Monotonicity. For the if side, assume that the projection condition (23) holds. Suppose that $A \vdash_{\alpha, p} B$ and $A \vdash_{\alpha, p} C$. It suffices to show that $A \wedge B \vdash_{\alpha, p} C$. If $p(\cdot|A \wedge B)$ is undefined, then by default $A \wedge B \vdash_{\alpha, p} C$. So suppose that $p(\cdot|A \wedge B)$ is defined and, thus, $p(\cdot|A)$ is

defined. Then argue as follows:

$$\begin{aligned}
& A \vdash_{\alpha,p} B, A \vdash_{\alpha,p} C \\
\Rightarrow & q \Vdash_{\alpha} B, q \Vdash_{\alpha} C && \text{letting } q = p(\cdot|A), \\
\Rightarrow & q \Vdash_{\alpha} B \wedge C, (B \wedge C) \leq B \\
\Rightarrow & q(\cdot|B) \Vdash_{\alpha} B \wedge C && \text{by condition (23)} \\
& && \text{and the existence of } q(\cdot|B), \text{ which equals } p(\cdot|A \wedge B), \\
\Rightarrow & p(\cdot|A \wedge B) \Vdash_{\alpha} B \wedge C && \text{since } p(\cdot|A \wedge B) = q(\cdot|B), \\
\Rightarrow & p(\cdot|A \wedge B) \Vdash_{\alpha} C \\
\Rightarrow & A \wedge B \vdash_{\alpha,p} C.
\end{aligned}$$

□

Proposition 10 (geometry of Or). *Let α be an acceptance rule that validates Reflexivity. Then, α validates Or if and only if the following condition holds: for each line segment L connecting two complementary facets $\mathcal{P}|B$ and $\mathcal{P}|\neg B$, and for each proposition A in \mathcal{A} , if α accepts A at both endpoints of L , then α accepts A at each point on L ; in light of lemma 3, the condition may be restated as:*

$$p(\cdot|B) \Vdash_{\alpha} A, p(\cdot|\neg B) \Vdash_{\alpha} A \implies p \Vdash_{\alpha} A. \quad (24)$$

Proof. For the only if side, argue as follows:

$$\begin{aligned}
& p(\cdot|B) \Vdash_{\alpha} A, p(\cdot|\neg B) \Vdash_{\alpha} B \\
\Rightarrow & B \vdash_{\alpha,p} A, \neg B \vdash_{\alpha,p} A \\
\Rightarrow & B \vee \neg B \vdash_{\alpha,p} A && \text{by axiom Or,} \\
\Rightarrow & p(\cdot|B \vee \neg B) \Vdash_{\alpha} A \\
\Rightarrow & p \Vdash_{\alpha} A.
\end{aligned}$$

For the converse, suppose that $A \vdash_{\alpha,p} C$ and $B \vdash_{\alpha,p} C$. It suffices to show that $A \vee B \vdash_{\alpha,p} C$. If both $p(\cdot|A)$ and $p(\cdot|B)$ are undefined, then $p(\cdot|A \vee B)$ is undefined and thus we have that $A \vee B \vdash_{\alpha,p} C$ by default. If one is defined and the other is undefined—say, $p(\cdot|A)$ is defined and $p(\cdot|B)$ is undefined—then $p(B) = 0$ and thus $p(\cdot|A \vee B) = p(\cdot|A)$ is defined, so:

$$\begin{aligned}
& A \vdash_{\alpha,p} C \\
\Rightarrow & p(\cdot|A) \Vdash_{\alpha} C \\
\Rightarrow & p(\cdot|A \vee B) \Vdash_{\alpha} C && \text{by } p(\cdot|A \vee B) = p(\cdot|A), \\
\Rightarrow & A \vee B \vdash_{\alpha,p} C.
\end{aligned}$$

Last, suppose that both $p(\cdot|A)$ and $p(\cdot|B)$ are defined. So $p(\cdot|A \vee B)$ is defined. Then

argue for Or as follows:

$$\begin{array}{ll}
A \vdash_{\alpha,p} C, B \vdash_{\alpha,p} C & \\
\Rightarrow p(\cdot|A) \Vdash_{\alpha} C, p(\cdot|B) \Vdash_{\alpha} C & \\
\Rightarrow q(\cdot|A) \Vdash_{\alpha} C, q(\cdot|B) \Vdash_{\alpha} C & \text{letting } q = p(\cdot|A \vee B), \\
& \text{so } q(\cdot|A) = p(\cdot|A) \text{ and } q(\cdot|B) = p(\cdot|B), \\
\Rightarrow q \Vdash_{\alpha} C \vee \neg A, q \Vdash_{\alpha} C \vee \neg B & (*) \text{ see the explanation below,} \\
\Rightarrow q \Vdash_{\alpha} C \vee \neg(A \vee B) & \text{by classical entailment,} \\
\Rightarrow q \Vdash_{\alpha} C \vee \neg(A \vee B), q \Vdash_{\alpha} A \vee B & \text{since } q(A \vee B) = 1 \text{ and proposition 8 applies,} \\
\Rightarrow q \Vdash_{\alpha} C & \text{by classical entailment,} \\
\Rightarrow p(\cdot|A \vee B) \Vdash_{\alpha} C & \\
\Rightarrow A \vee B \vdash_{\alpha,p} C. &
\end{array}$$

It only remains to establish step (*). By the symmetric roles of A and B , it suffices to show that $q(\cdot|A) \Vdash_{\alpha} C$ implies that $q \Vdash_{\alpha} C \vee \neg A$. If $q(\cdot|\neg A)$ is undefined, then $q(A) = 1 - q(\neg A) = 1 - 0 = 1$ and thus $q = q(\cdot|A) \Vdash_{\alpha} C \leq C \vee \neg A$, so $q \Vdash_{\alpha} C \vee \neg A$. If $q(\cdot|\neg A)$ is defined, then we have both that $q(\cdot|A) \Vdash_{\alpha} C$ and that $q(\cdot|\neg A) \Vdash_{\alpha} \neg A$ (by acceptance of every certain proposition). So we have both that $q(\cdot|A) \Vdash_{\alpha} C \vee \neg A$ and that $q(\cdot|\neg A) \Vdash_{\alpha} C \vee \neg A$ (by classical entailment). Hence $q \Vdash_{\alpha} C \vee \neg A$, by the convexity condition (24). \square

10 The Geometry of System P

In this section, we examine the geometrical constraints on acceptance that are implied jointly by the axioms of system P of nonmonotonic reasoning. It is an easy corollary of the geometrical characterizations in the preceding section that:

Theorem 2 (Lin 2010). *Each probalogical rule validates system P.*

Proof sketch. When $|\mathcal{E}| = 3$, one can easily verify that probalogical rules satisfy the geometric conditions given in propositions 7-10 when the consequence relations in question have antecedents of nonzero probability. The routine verification can be easily generalized to a proof for all countable dimensional cases. \square

We now proceed to establish a partial converse to theorem 2. Recall that acceptance

zones for answers have the following form under probalogical rules:

$$\begin{aligned}
p \Vdash_{\nu} E_i &\iff E_i = \nu(p) \\
&\iff E_i = \bigwedge \{ \neg E_j : \sigma(p)_j \triangleleft_j 1 - r_j \} \\
&\iff \forall j \neq i, \sigma(p)_j \triangleleft_j 1 - r_j \\
&\iff \forall j \neq i, \frac{p_j}{\max_k p_k} \triangleleft_j 1 - r_j \\
&\iff \forall j \neq i, \frac{p_j}{p_i} \triangleleft_j 1 - r_j.^{17}
\end{aligned}$$

To allow for more generalized rules entertained below, we relax the conditions that the rejection threshold $1 - r_j$ is in the unit interval and that it is constant for all i . Accordingly, say that the acceptance zone of answer E_i under α is a *blunt diamond* (figure 19.a) if and only if it takes the following form: there exist thresholds $\{t_{ij} : j \in I \setminus \{i\}\}$ in interval $[0, \infty]$ and inequalities $\{\triangleleft_{ij} : j \in I \setminus \{i\}\}$ that are either \leq or $<$, such that for each $p \in \mathcal{P}$:

1. $p \Vdash_{\alpha} E_i \iff \forall j \neq i, \frac{p_j}{p_i} \triangleleft_{ij} t_{ij}$;
2. if $\triangleleft_{ij} = \leq$ then $t_{ij} < \infty$;
3. if $\triangleleft_{ij} = <$ then $t_{ij} > 0$.

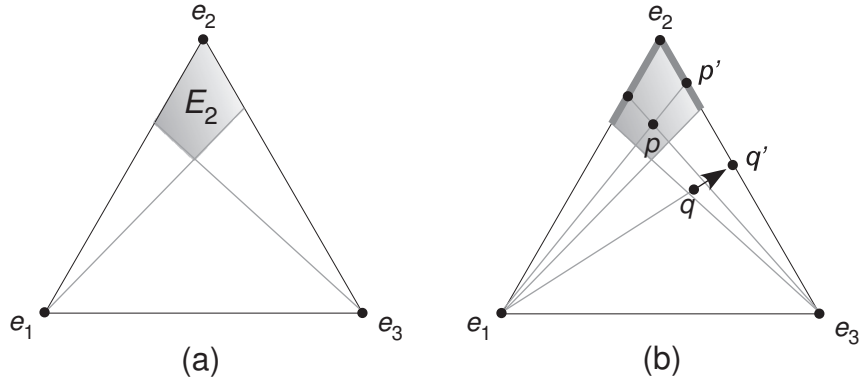

Figure 19: acceptance zone of E_2

Say that acceptance rule α is *corner-convex* if and only if (i) $\alpha(e_i) = E_i$ for each $i \in I$, and (ii) for each $p \in \mathcal{P}$ such that $\alpha(p) = E_i$, we have that $\alpha(q) = E_i$ for all q in line segment $\overline{p e_i}$. Corner-convexity is a very natural constraint on acceptance rules that is satisfied by Lockean, Kyburgian and Pollockian rules. Our partial converse to theorem 2 is as follows.

Theorem 3 (blunt diamond). *Let \mathcal{E} be finite.¹⁸ If acceptance rule α is everywhere consistent, satisfies corner-convexity, and validates system P, then for each answer E_i to question \mathcal{E} , the acceptance zone of E_i under α is a blunt diamond.*

Proof sketch. Here we present a geometric argument for case $|\mathcal{E}| = 3$, which is easily generalized to each finite dimension. Solve for the acceptance zone of E_2 under α , as depicted in figure 19.b. By corner-convexity, the credal states along side $\overline{e_2 e_1}$ of the triangle at which α accepts E_2 form a continuous, unbroken line segment with e_2 as an endpoint, which is depicted as the heavy, grey line segment lying on $\overline{e_2 e_1}$. The same is true for side $\overline{e_2 e_3}$.¹⁹ Connect the endpoints of the grey line segments to the opposite corners by straight lines, which enclose the grey blunt diamond at the corner e_2 .

Argue as follows that $p \Vdash_\alpha E_2$, for each point p in the blunt diamond. Consider the projection p' of p to the facet $\mathcal{P}[(E_2 \vee E_3)]$. Note that p' is in the heavy, grey line segment along side $\overline{e_2 e_3}$. On line segment $\overline{e_1 p'}$ ray, acceptance rule α accepts E_1 at one endpoint (e_1) and accepts E_2 at the other endpoint (p'), so α accepts $E_1 \vee E_2$ at both endpoints. Then, by proposition 10, we have that $p \Vdash_\alpha E_1 \vee E_2$. By applying the same argument to the projection of p to the facet for proposition $E_1 \vee E_3$, we have that $p \Vdash_\alpha E_3 \vee E_2$. Then by classical entailment, $p \Vdash_\alpha E_2$, as required.

Argue as follows that $q \not\Vdash_\alpha E_2$, for each point q outside of the blunt diamond. Since q lies outside of the blunt diamond, there exists at least one answer E_i other than E_2 such that the projection q' of q to the facet $\mathcal{P}[(E_2 \vee E_i)]$ does not touch the grey line segment along side $\overline{e_2 e_i}$. Figure 19.b. illustrates the case for $i = 3$. Suppose for reductio that $q \Vdash_\alpha E_2$. Then, by applying proposition 9 to the projection q' of q , we have that $q' \Vdash_\alpha E_2$. But $q' \not\Vdash_\alpha E_2$, for q' lies outside of the grey line segment—contradiction. \square

11 AGM Geometry is Trivial

A stronger system R of nonmonotonic logic is obtained from P by adding the following axiom (Kraus and Magidor 1992):

$$\text{(Rational Monotonicity)} \quad \frac{\begin{array}{ccc} A & \not\vdash & \neg B \\ A & \vdash & C \end{array}}{A \wedge B \quad \vdash \quad C}$$

¹⁸When \mathcal{E} is countably infinite, we need to assume the infinite disjunctive generalization of axiom Or to prove the proposition.

¹⁹There is an issue whether the line segments are open or closed at the endpoints distinct from e_2 , which would give rise to a possible mixture of strict and weak inequalities, as stated in the theorem. That detail is handled in the formal proof in (Lin 2010), but is ignored here.

Recall the *probabilistic* Ramsey test assumed in the preceding sections of this paper:

$$A \vdash_{p,\alpha} B \iff \alpha(p(\cdot|A)) \leq B \text{ or } p(A) = 0.$$

In light of this test, validation of system R trivializes uncertain acceptance. Say that acceptance rule α is *almost surely skeptical* about answer E_i to \mathcal{E} if and only if α accepts E_i only over a subset of \mathcal{P} of Lebesgue measure 0. Say that α is *almost surely opinionated* if and only if α fails to accept some answer or other to \mathcal{E} only over a subset of \mathcal{P} of Lebesgue measure 0. Thus, an opinionated rule accepts answers arbitrarily close to the credal state that is indifferent over all the answers. The trouble with system R is that the acceptance rules that validate it are all trivial, in the sense that they are either almost surely opinionated or almost surely skeptical regarding at least one answer, as long as the question has at least three answers.

Theorem 4 (skepticism or opinionation). *Let question \mathcal{E} be finite, with cardinality ≥ 3 . Suppose that acceptance rule α for \mathcal{E} is everywhere consistent, satisfies corner-convexity, and validates system R. Then α is either almost surely skeptical about some answer or almost surely opinionated.*

Since the probabilistic Ramsey test is based on probabilistic conditioning, acceptance rules must respect the geometry of conditioning in order to validate axioms of nonmonotonic reasoning. What theorem 4 says is that these geometrical constraints become hopelessly severe when one adds rational monotonicity to system P. Of course, the situation is quite different if one drops probabilistic conditioning from the Ramsey test.²⁰ A *conditional* acceptance rule is a mapping $\beta : \mathcal{P} \times \mathcal{A} \rightarrow \mathcal{A}$, where $\beta(p|A) = B$ may be interpreted as saying that B is the strongest proposition accepted in p in light of new information A . Then one can state a new, *non-probabilistic* Ramsey test directly in terms of conditional acceptance:

$$A \vdash_{\beta,p} B \iff \beta(p|A) \leq B. \tag{25}$$

Conditional acceptance is an abstract concept that can be filled out in various different ways. For example, say that conditional acceptance rule β is *Bayesian* if and only if there exists a (non-conditional) acceptance rule α such that:

$$\beta(p|A) = \begin{cases} \alpha(p(\cdot|A)) & \text{if } p(A) > 0; \\ \perp & \text{otherwise.} \end{cases} \tag{26}$$

When β is Bayesian, the new information A is used to condition the credal state p to obtain $p(\cdot|A)$ and then some new propositional belief state S' is accepted in light

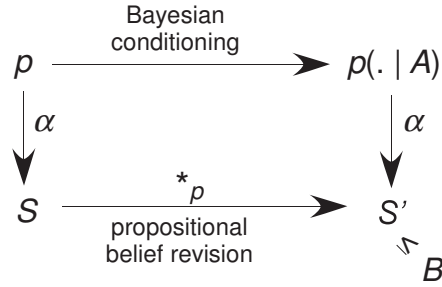

Figure 20: two paths

of $p(\cdot|A)$ (the upper path in figure 20). If β is Bayesian, then the non-probabilistic Ramsey test for β is equivalent to the probabilistic Ramsey test for α , so theorem 4 still applies to β . But β need not be Bayesian. For example, β may sidestep Bayesian conditioning entirely by using α to accept a propositional belief state $S = \alpha(p)$ in p and by subsequently applying a propositional belief revision operator $*_p$ (that may depend on p) to convert $\alpha(p)$ into a new propositional belief state $S' = \alpha(p) *_p A$ (the lower path in figure 20).

$$\beta(p|A) = \alpha(p) *_p A. \quad (27)$$

In that case, the validation of system R depends entirely on the propositional revision operator $*_p$ —probabilistic conditioning and α are both irrelevant, so the geometrical proof of theorem 4 is also sidestepped. For example, to validate Rational Monotonicity, just stipulate that $B *_p A = B \wedge A$ when B is logically compatible with A . It is a familiar fact of nonmonotonic logic that when $*$ is an *AGM belief revision operator* (Harper 1975, Alchourron, Gardenfors, and Makinson 1985), system R is sound and complete with respect to the propositional Ramsey test (Makinson and Gardenfors 1991).

The escape route just described does not really vindicate or explain Rational Monotonicity from a Bayesian perspective, since Bayesian conditioning is bypassed and Rational Monotonicity is simply imposed on the propositional belief revision operator $*_p$. Moreover, as explained above, non-Bayesian conditional acceptance rules validate system R. On the other hand, it is an immediate corollary of theorem 2 that the Bayesian rules of form:

$$\beta(p|A) = \nu(p(\cdot|A)) \quad (28)$$

all validate system P with respect to the non-probabilistic Ramsey test. We propose, therefore, that system P reflects Bayesian ideals better than system R.

²⁰The approach that follows is due to Hannes Leitgeb, who presented his unpublished results at the Opening Celebration of the Center for Formal Epistemology at Carnegie Mellon University in the Summer of 2010. The discussion in this section is based on detailed slides he presented at that meeting and on personal communication with him at that time.

The proof of theorem 4 proceeds by a sequence of lemmas and occupies the balance of this section. First note that the blunt diamond theorem applies. Let D_i be the blunt diamond acceptance zone of E_i with vertex v_{ij} on side $\overline{e_i e_j}$, for all distinct indices i, j in I . A given threshold t_{ij} in the unit interval uniquely determines, and is uniquely determined by, the *vertex* v_{ij} of the blunt diamond on side $\overline{e_i e_j}$, according to the relation:

$$\begin{aligned} \frac{v_{ij}(E_j)}{v_{ij}(E_i)} &= t_{ij}, \\ v_{ij}(E_k) &= 0 \quad \text{for all } k \text{ in } I \text{ distinct from } i \text{ and } j. \end{aligned}$$

Lemma 4. *Assume the suppositions in theorem 4. Suppose, further, that α is almost surely skeptical about none of the answers to \mathcal{E} . Then for all distinct indices i, j in I ,*

$$v_{ij} = v_{ji}.$$

Proof. Let i, j, k be three distinct indices in I . Let \mathcal{P}_{ijk} be the two dimensional facet $\mathcal{P}(E_i \vee E_j \vee E_k)$. Consider vertex v_{ik} of blunt diamond D_i , and vertex v_{jk} of blunt diamond D_j , as depicted in figure 21.(a). Vertex v_{ik} does not coincide with e_i , since α

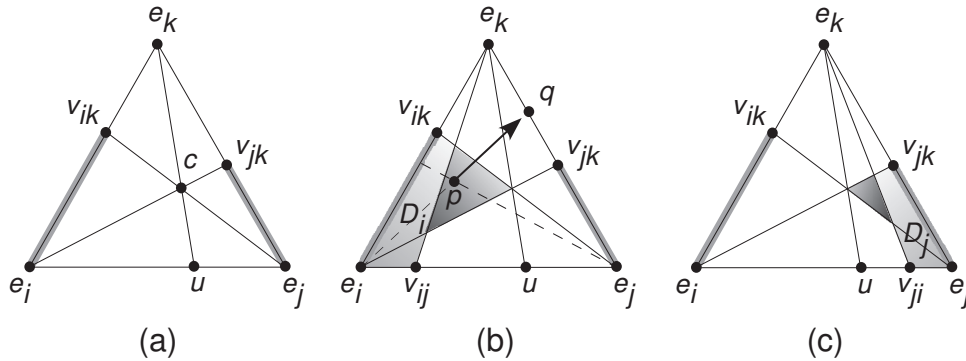

Figure 21: two ways Rational Monotonicity can fail

is not almost surely skeptical about answer E_i . Vertex v_{ik} also does not coincide with e_k ; otherwise, since α is not almost surely skeptical about answer E_k , blunt diamond D_k would have nonempty intersection with D_i along side $\overline{e_i e_k}$ —contradiction to the everywhere consistency of α . Therefore, v_{ik} lies strictly in between e_i and e_k . Similarly, v_{jk} lies strictly in between e_j and e_k . It follows that α accepts E_i at every point in the interior of line $\overline{e_i v_{ik}}$. And α accepts E_j at every point in the interior of line $\overline{e_j v_{jk}}$. Let c be the intersection of line $\overline{e_i v_{jk}}$ with line $\overline{e_j v_{ik}}$, which lies in the interior of facet \mathcal{P}_{ijk} . Let u be the point on side $\overline{e_i e_j}$ such that line $\overline{u e_k}$ passes through c .

Argue as follows that vertex v_{ij} of blunt diamond D_i lies on line $\overline{u e_j}$. Suppose the contrary for reductio. Then v_{ij} lies on $\overline{e_i u}$ but does not coincide with u , as depicted in figure 21.(b). So there exists a point p in facet \mathcal{P}_{ijk} that lies in the interior of the triangle bounded by lines $\overline{e_i v_{jk}}$, $\overline{e_j v_{ik}}$, and $\overline{e_k v_{ij}}$. E_i is not accepted at p . For the acceptance zone of E_i in facet \mathcal{P}_{ijk} is a two-dimensional blunt diamond with vertices e_i , v_{ij} , and v_{ik} , so it does not contain p . Also, E_j is not accepted at p . For the acceptance zone of E_j in facet \mathcal{P}_{ijk} is a subset of triangle $\triangle e_i e_j v_{jk}$, so it does not contain p . But p lies on a line that connects e_j to a point in the interior of line $\overline{e_i v_{ik}}$, with $E_i \vee E_j$ accepted at both of the endpoints. Hence $E_i \vee E_j$ is accepted at p , by proposition 10. Therefore, $E_i \vee E_j$ is accepted as *strongest* at p ; namely, $\alpha(p) = E_i \vee E_j$. But $E_i \vee E_j$ is consistent with $E_j \vee E_k$. So, by Rational Monotonicity, we have that $E_j \vee E_k \vdash_{\alpha, p} E_i \vee E_j$. Hence, by Reflexivity and And, we have that $E_j \vee E_k \vdash_{\alpha, p} E_j$. Let $q = p(\cdot | E_j \vee E_k)$. So α accepts E_j at q . But q lies outside of line $\overline{e_j v_{jk}}$, so α does not accept E_j at q —contradiction.

We have established that vertex v_{ij} of blunt diamond D_i lies on line $\overline{u e_j}$. By the same argument (with i and j exchanged), vertex v_{ji} of blunt diamond D_j lies on line $\overline{e_i u}$ (otherwise, a similar contradiction would arise from figure 21.(c)). Conclude that $v_{ij} = u = v_{ji}$, for otherwise there would be nonempty intersection of D_i and D_j along side $\overline{e_i e_j}$, contradicting the everywhere consistency of α . \square

Lemma 5. *Continuing from lemma 4, let p be a probability measure in the interior of \mathcal{P} that has an open neighborhood disjoint from the acceptance zones of all answers to \mathcal{E} . Then, for each answer E_i to \mathcal{E} , there exists an answer E_j to \mathcal{E} distinct from E_i such that $E_i \vee E_j \vdash_{\alpha, p} E_j$.*

Proof. Since p is bounded away by an open neighborhood from D_i , there exists index j in I distinct from i such that $p(E_j)/p(E_i)$ is strictly greater than $v_{ij}(E_j)/v_{ij}(E_i)$ (by the definition of a blunt diamond). Let $q = p(\cdot | E_i \vee E_j)$. So q lies on side $\overline{e_i e_j}$ and is closer to e_j than v_{ij} is. Since $v_{ij} = v_{ji}$ (by lemma 4), q is closer to e_j than v_{ji} is. So q lies on line $\overline{e_j v_{ji}}$ and does not coincide with v_{ji} —and hence q is in the acceptance zone of E_j . But $q = p(\cdot | E_i \vee E_j)$. Hence $E_i \vee E_j \vdash_{\alpha, p} E_j$, as required. \square

A *self-defeating cycle* with respect to nonmonotonic consequence relation \vdash and question \mathcal{E} is a finite sequence $(E_i)_{1 \leq i \leq n}$ of answers to \mathcal{E} such that $E_i \vee E_{i+1} \vdash E_{i+1}$ and $E_n \vee E_1 \vdash E_1$, for all positive integers $i < n$.

Lemma 6. *If \vdash satisfies system P and has a self-defeating cycle $(E_i)_{1 \leq i \leq n}$, then $\bigvee_{1 \leq i \leq n} E_i \vdash \perp$.*

Proof. For each i such that $1 \leq i < n$, we have that $E_i \vee E_{i+1} \vdash E_{i+1}$ and that E_{i+1} entails $\neg E_1$, so $E_i \vee E_{i+1} \vdash \neg E_1$ (by Right Weakening). Hence, $\bigvee_{1 \leq i \leq n} E_i \vdash \neg E_1$ (by $n-2$ applications of Or). By the same argument (with 1 replaced by j), $\bigvee_{1 \leq i \leq n} E_i \vdash \neg E_j$

for all j such that $1 \leq j \leq n$. But $\bigvee_{1 \leq i \leq n} E_i \sim \bigvee_{1 \leq i \leq n} E_i$ (by Reflexivity). So $\bigvee_{1 \leq i \leq n} E_i \sim \perp$ (by n applications of And), as required. \square

Lemma 7. *Continuing from lemma 5, if $\sim_{\alpha,p}$ has a self-defeating cycle, then α is not everywhere consistent.*

Proof. Note that α validates system R and, *a fortiori*, system P, so lemma 6 applies. Suppose that $\sim_{\alpha,p}$ has a self-defeating cycle $(E_i)_{1 \leq i \leq n}$. Then $\bigvee_{1 \leq i \leq n} E_i \sim_{\alpha,p} \perp$. So α accepts \perp at the state obtained from p by conditioning on $\bigvee_{1 \leq i \leq n} E_i$ (which is well-defined, since p lies in the interior of \mathcal{P} by the hypothesis in lemma 5). \square

Proof of Theorem 4. Suppose that α is almost surely skeptical about none of the answers to \mathcal{E} —so lemma 4 applies. Suppose for reductio that α is not almost surely opinionated. Then there exists a probability measure p in the interior of \mathcal{P} that has an open neighborhood disjoint from the acceptance zones of all answers to \mathcal{E} —so lemma 5 applies. That is, for each answer E_i to \mathcal{E} , there exists an answer E_j to \mathcal{E} distinct from E_i such that $E_i \vee E_j \sim_{\alpha,p} E_j$. Then, since \mathcal{E} contains only finitely many answers, $\sim_{\alpha,p}$ must have a self-defeating cycle. So, by lemma 7, α is not everywhere consistent—contradiction. \square

12 A New Probabilistic Semantics for Flat Conditionals

Axiom system P is characteristic of Adams' logic of flat conditionals, so it is not surprising that the probalogical rules yield a new probabilistic semantics for which Adams' logic is sound. In fact, Adams' logic is both sound and complete for the new semantics.

Let \mathcal{L} be a set of sentences of a propositional language that is closed under conjunction, disjunction, and negation. Let $>$ be a connective standing for “if ... then ...”. The language for the logic of *flat conditionals*, written $\mathcal{L}^>$, is the set of all sentences $\phi > \psi$ with $\phi, \psi \in \mathcal{L}$. Adams' (1975) logic of flat conditionals is just system P construed as a system of rules of inference, except that the symbol for consequence relation \sim is now replaced by connective $>$. Say that γ is *derivable* from Γ in Adams' logic of flat conditionals, written $\Gamma \vdash_{\text{Adams}} \gamma$, if and only if γ is derivable from Γ in a finite number of steps using the rules of inference in system P.

A *probabilistic model of acceptance* for language $\mathcal{L}^>$ is a triple:

$$M = (\alpha, p, \llbracket \cdot \rrbracket),$$

where $\alpha : \mathcal{P} \rightarrow \mathcal{A}$ is an acceptance rule, p is a probability measure in the domain \mathcal{P} of α , and $\llbracket \cdot \rrbracket$ is a classical interpretation of \mathcal{L} to the codomain \mathcal{A} of α . When $M = (\alpha, p, \llbracket \cdot \rrbracket)$, say that α is the *underlying* acceptance rule of M . Let $\phi > \psi$ be a flat conditional in

$\mathcal{L}^>$. *Acceptance* of flat conditional $\phi > \psi$ in model $M = (\alpha, p, \llbracket \cdot \rrbracket)$, written $M \Vdash \phi > \psi$, is defined by the probabilistic Ramsey test:

$$\begin{aligned}
M \Vdash \phi > \psi &\iff \llbracket \phi \rrbracket \sim_{\alpha, p} \llbracket \psi \rrbracket, \\
&\iff \begin{cases} \text{either } \llbracket \psi \rrbracket \text{ is accepted by rule } \alpha \text{ at credal state } p(\cdot \mid \llbracket \phi \rrbracket) \\ \text{or } p(\llbracket \phi \rrbracket) = 0. \end{cases}
\end{aligned}$$

Let Γ be a set of flat conditionals in $\mathcal{L}^>$. Acceptance of Γ in model M is defined by: $M \Vdash \Gamma$ if and only if $M \Vdash \gamma$ for all $\gamma \in \Gamma$. Validity is defined straightforwardly, as preservation of acceptance. Let \mathcal{C} be a class of acceptance rules. Say that \mathcal{C} *validates* the inference from Γ to γ , written $\Gamma \Vdash_{\mathcal{C}} \gamma$, if and only if for each probabilistic model M whose underlying acceptance rule is in \mathcal{C} , if $M \Vdash \Gamma$, then $M \Vdash \gamma$.

The proposed probabilistic semantics has the following attractive properties: (i) it is based on the probabilistic Ramsey test for accepting conditionals; (ii) it defines validity simply as preservation of acceptance, which improves upon Adams' (1975) ϵ - δ semantics; and (iii) it allows for accepting propositions of probabilities significantly less than 1, which improves upon Pearl's (1989) infinitesimal semantics. To establish the soundness and completeness result for Adams' logic of flat conditionals, it suffices to assume that the underlying acceptance rule is probalogical:

Theorem 5 (soundness and completeness, Lin 2010). *Let \mathcal{N} be the class of the probalogical acceptance rules. Then, for each finite sentence set Γ and each sentence γ in the language $\mathcal{L}^>$ of flat conditionals, $\Gamma \vdash_{\text{Adams}} \gamma$ if and only if $\Gamma \Vdash_{\mathcal{N}} \gamma$.*

13 Question-Invariance

To this point, we have considered acceptance only within a fixed question \mathcal{E} . But one can and should consider the behavior of acceptance rules *across* questions. Let Ω denote some infinite collection of possibilities. A *question* $\mathcal{E} = \{E_i : i \in I\}$ is a countable partition of Ω such that each answer/cell E_i is infinite—the requirement of infinite answers rules out the artificial possibility of a maximally informative question whose answers cannot be strengthened. Let $\mathcal{A}_{\mathcal{E}}$ denote the least collection of propositions containing \mathcal{E} and closed under negation and countable disjunction and conjunction. Let \mathbb{E} denote the set of all such questions over Ω , and let \mathbb{P} denote the set of all countably additive probability measures p such that p is defined on $\mathcal{A}_{\mathcal{E}}$ for some question \mathcal{E} in \mathbb{E} . If p is in \mathbb{P} , let \mathcal{A}_p denote the domain of p and let \mathcal{E}_p denote the (unique) question that generates \mathcal{A}_p . A (*cross-question*) *acceptance rule* is a map β defined on \mathbb{P} such that β always maps p to a proposition in \mathcal{A}_p . Then the rules discussed earlier in this paper

can be defined explicitly across questions as follows:

$$\begin{aligned}
\lambda_r(p) &= \bigwedge \{ \neg E_i : p_i \leq 1 - r \text{ and } i \in I_p \}; \\
\lambda(p) &= \lambda_{s(p)}(p), \quad \text{where } s(p) = 1 - \frac{1}{2|I_p|}; \\
\nu_r(p) &= \bigwedge \{ \neg E : \sigma(p)_i \triangleleft_i 1 - r_i \text{ and } i \in I_p \}; \\
\pi_r(p) &= \begin{cases} \top & \text{if } \lambda_r(p) = \perp; \\ \lambda_r(p) & \text{otherwise.} \end{cases}
\end{aligned}$$

Rule λ_r is the Lockean rule with a fixed threshold across all questions in \mathbb{E} . Rule ν_r is the probalogical rule. Rule λ is the ad hoc Lockean rule whose threshold is adjusted to avoid lottery paradoxes in finite questions. Rule π_r is the Pollockian rule that substitutes \top for \perp whenever the latter is produced by λ_r .

Say that cross-question acceptance rule β is *question-invariant* if and only if:

$$p(A) = q(A) \implies (p \Vdash_{\beta} A \iff q \Vdash_{\beta} A),$$

for each p, q in \mathbb{P} and for each A that is in both \mathcal{A}_p and \mathcal{A}_q . Question-invariance is appealing. First, question-invariance makes it easier to compute whether to accept A in light of p , since all of the detailed structure of p aside from $p(A)$ can be ignored. Second, question-invariance allows for the accumulation of accepted propositions as one's question is refined by new concepts and theories. Third, question-invariance allows individual scientists pursuing distinct questions to *pool* their accepted conclusions. Probalogical rules, however, are not even remotely question-invariant. For example, in a four ticket lottery, the probalogical rule $\nu_{2/3}$ licenses acceptance of "ticket 1 will lose" when the question is "will ticket 1 lose or not?", but not when the question is "which ticket will win?". That makes one wonder whether the question-dependence of probalogical rules is a design defect that could have been avoided. We now proceed to demonstrate that *no* question-invariant rule has the three crucial virtues of the probalogical rules: consistency, logical closure, and non-skeptical acceptance of uncertain propositions.

Here is the first sign of trouble. Say that acceptance rule β is *non-skeptical* about answer E in question \mathcal{E} if and only if β accepts E at some probability measure p defined on $\mathcal{A}_{\mathcal{E}}$ such that $p(E) < 1$. Say that acceptance rule β is *gullible* about E in \mathcal{E} if and only if β accepts E at some p defined on $\mathcal{A}_{\mathcal{E}}$ such that $p(E) = 0$. Then:

Proposition 11. *Suppose that β is question-invariant. If β is non-skeptical about answer E in ternary question \mathcal{E} , then β is gullible about E in \mathcal{E} .*

Proof. Consider the equilateral triangle $\triangle quv$ depicted in figure 22.a. Note that p

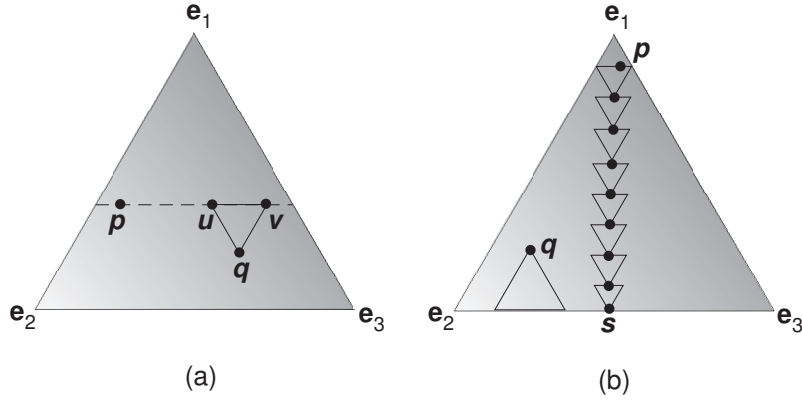

Figure 22: triangles preserve acceptance

lies on a line parallel to $\overline{e_2 e_3}$ extending the base \overline{uv} of the triangle $\triangle quv$ and q is at the apex. Suppose that $p \Vdash_{\beta} E_1$. Then $u, v \Vdash_{\beta} E_1$, by question-invariance. So $u \Vdash_{\beta} \neg E_2$ and $v \Vdash_{\beta} \neg E_3$. Then by question-invariance again, $q \Vdash_{\beta} \neg E_2$ and $q \Vdash_{\beta} \neg E_3$. So $q \Vdash_{\beta} \neg E_2 \wedge \neg E_3 = E_1$. Therefore, if β accepts E_1 at p , then β also accepts E_1 at q . Now we can chain such triangles all the way to the bottom of \mathcal{P}_3 to obtain s such that $s \Vdash E_1$ and $s(E_1) = 0$. Note that if $p(E_1) < 1$, there is room in \mathcal{P}_3 for such a chain. \square

It gets worse. Say that β is *dogmatic* about answer E in question \mathcal{E} if and only if β accepts E at each probability measure defined on $\mathcal{A}_{\mathcal{E}}$.

Proposition 12. *Suppose that β is question-invariant. If β is non-skeptical about answer E in ternary question \mathcal{E} , then β is dogmatic about E in \mathcal{E} .*

Proof. Consider the situation depicted in figure 22.b, in which question-invariant rule β accepts E_1 at s , with $s(E_1) = 0$, and let q be an arbitrary credal state in \mathcal{P}_3 . Then there exists an equilateral triangle with s on its base and with q at its apex, so β also accepts E_1 at the arbitrarily chosen state q . \square

Here is the *coup de grâce*. Say that β is *everywhere inconsistent* if and only if $\beta(p) = \perp$, for all p in \mathbb{P} . Nothing could be more useless than an acceptance rule that accepts the contradiction in every possible credal state and every possible question.

Theorem 6. *Suppose that β is question-invariant. If β is non-skeptical about at least two distinct answers in some ternary question, then β is everywhere inconsistent.*

Proof. Suppose that β is non-skeptical about at least two distinct answers E_i, E_j in ternary question \mathcal{E} . Then, by proposition 12, β accepts $E_i \wedge E_j$ and, thus, \perp at every

state in question \mathcal{E} . But \perp has the same probability, namely 0, at every state in every question. So, by question-invariance, \perp is accepted at every state in every question. \square

It follows from the preceding propositions that *none* of the rules listed above is question-invariant. That fact is obvious for probalogical rules and the ad hoc rules, all of which base acceptance explicitly on the underlying question. However, even the logically closed Lockean rule with fixed threshold is question-dependent whenever the threshold is strictly between 0 and 1—for then the rule is neither skeptical nor everywhere inconsistent (at threshold 0 it is everywhere inconsistent and at threshold 1 it is skeptical). If closure under conjunction is dropped, the Lockean rule with a fixed threshold is question-invariant and is non-skeptical, but is also consistent, so it escapes theorem 6 (recall that set-valued rules are not covered by that proposition).

We are inclined to view theorem 6 as a reductio argument against question-invariance. That conclusion fits naturally with a minimalist, pragmatic interpretation of accepted proposition A as a more or less apt *proxy* for one’s underlying credal state p , rather than as new “information” that alters p (e.g., by conditioning p on A). Question-invariance would be *nice*, but it is not rationally mandated under the minimalist conception of acceptance, and its price in terms of logical virtues *within* questions is too high.

14 Refinement-Monotonicity

Invariance across all questions is a strong requirement. In this section, we consider the consequences of requiring invariance only over questions that refine or coarsen the given question. Say that \mathcal{E} *refines* \mathcal{F} (or that \mathcal{F} *coarsens* \mathcal{E}) if and only if each answer to \mathcal{E} entails some answer to \mathcal{F} . When \mathcal{E} refines \mathcal{F} , write $\mathcal{E} \preceq \mathcal{F}$. By extension, say that p *refines* q (written $p \preceq q$) when q is the restriction of p to \mathcal{A}_q , which implies that $\mathcal{E}_p \preceq \mathcal{E}_q$. Say that cross-question acceptance rule β is *refinement-invariant* if and only if:

$$p \preceq q \implies (p \Vdash_{\beta} A \iff q \Vdash_{\beta} A),$$

for each p, q in \mathbb{P} and for each proposition A in \mathcal{A}_q . However:

Proposition 13. *Refinement-invariance is equivalent to question-invariance.*

Proof. Suppose that $p(A) = q(A)$. Let $r = (p(A), 1 - p(A))$ over question $\{A, \neg A\}$. Then $p \preceq r \succeq q$. By refinement-invariance, it follows that $p \Vdash_{\beta} A \iff q \Vdash_{\beta} A$. The converse is immediate. \square

Refinement-invariance demands that acceptance be preserved under both refinement and coarsening. Since questions tend to become more precise as inquiry proceeds,

perhaps it suffices merely to preserve acceptance under refinement. Accordingly, say that β is *refinement-monotone* if and only if:

$$p \preceq q \implies \beta(p) \leq \beta(q),$$

for all p, q in \mathbb{P} . Refinement-monotonicity suffices for the accumulation of accepted conclusions as the question is refined and for the pooling of propositions accepted across diverse questions. With respect to the latter, let p, q, r be in \mathbb{P} . Say that r is a *conjunction* of p, q if and only if r is a maximally coarse common refinement of p, q . Then say that β *preserves conjunction* if and only if $\beta(r) \leq \beta(p) \wedge \beta(q)$, for each p and q in \mathbb{P} and for each conjunction r of p and q . Then it is easy to show that:

Proposition 14. *Conjunction-preservation is equivalent to refinement-monotonicity.*

Alas, probalogical rules also violate refinement-monotonicity—as witnessed by the simple lottery example in the preceding section of this paper. Again, the failure is not a defect but an ineluctable consequence of the logical virtues of probalogical rules.

Theorem 7. *Suppose that β is refinement-preserving, validates system \mathbf{P} in each question, and is non-skeptical about both answers in some binary question. Then there exists a facet of at least two dimensions over which β accepts \perp everywhere.*

The alternative rules listed above also violate refinement-monotonicity, even though they all fail to validate system \mathbf{P} . Choosing a probalogical rule at least yields the net advantage of validating \mathbf{P} .

The proof of theorem 7 proceeds by a sequence of lemmas that rely heavily on the geometrical characterizations of the axioms of \mathbf{P} established in section 9. Consider the binary question $\{E_0, F_0\}$, whose space of credal states is depicted in figure 23.a as the line next to the triangle. Assume that β is non-skeptical about answers E_0 and F_0 , so that β accepts E_0 at p_0 and F_0 at q . Since E_0 is infinite, split E_0 into infinite answers F_1 and E_1 to produce the refined, ternary question $\{F_0, F_1, E_1\}$ (figure 23.b). Suppose that β is refinement-monotone. Then proposition F_0 is accepted throughout the line segment L depicted in figure 23.b, which is defined to be the set of all credal states that refine q . Similarly, proposition $E_0 = E_1 \vee F_1$ is accepted throughout the line segment M , which is the set of all credal states that refine p_0 . Let line segment N connect the right endpoint of L in figure 23.b to the opposite corner e_1 , intersecting M at credal state u ; then project u to the (one-dimensional) facet for proposition $E_1 \vee F_0$ to obtain credal state p_1 . The following lemma concerns p_1 .

Lemma 8. *Suppose that β is refinement-monotone and validates system \mathbf{P} . Then $p_1 \Vdash_{\beta} E_1$.*

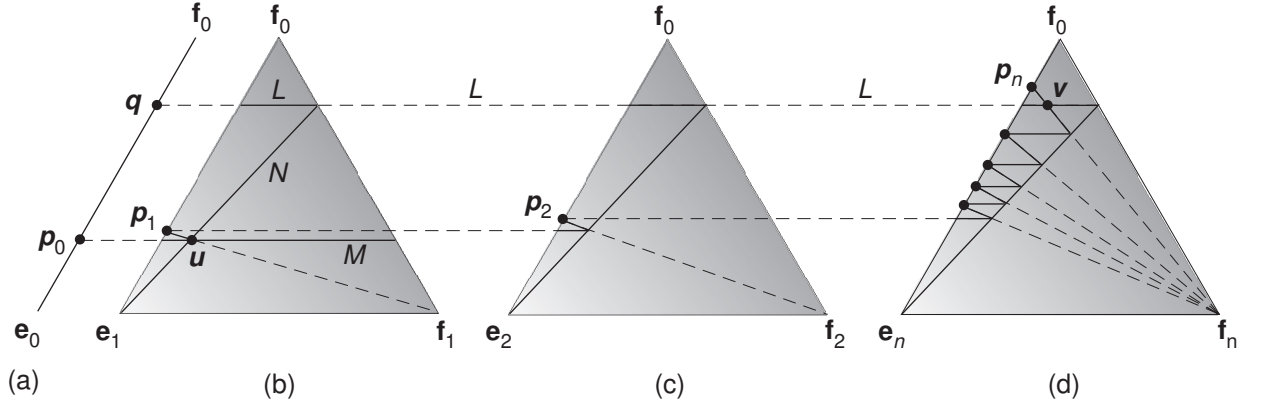

Figure 23: acceptance snakes up the triangle

Proof. Proposition E_1 is accepted by β at e_1 , by the geometry of Reflexivity (proposition 8); and F_0 is accepted at each point on L , by construction. So the disjunction $E_1 \vee F_0$ is accepted by β at both endpoints of N . Then, since u lies on N , we have that $u \Vdash_{\beta} E_1 \vee F_0$, by the geometry of Or (proposition 10). We have noted that $u \Vdash_{\beta} E_1 \vee F_1$. So $u \Vdash_{\beta} E_1$, because $E_1 = (E_1 \vee F_0) \wedge (E_1 \vee F_1)$. Then, since p_1 is the projection of u onto the facet for a logical consequence of E_1 , the geometry of Cautious Monotonicity (proposition 9) yields that $p_1 \Vdash_{\beta} E_1$, as required. \square

The result is that E_1 is accepted by β with a lower probability than E_0 . Split E_1 into two infinite, exclusive propositions E_2 and F_2 and, thus, obtain the finer, quaternary question $\{F_0, F_1, F_2, E_2\}$. Restrict attention to the two-dimensional, triangular facet for proposition $F_0 \vee F_2 \vee E_2$, as depicted in figure 23.c. Construct credal state p_2 as we did for p_1 , and argue similarly that E_2 is accepted at p_2 , with an even lower probability than the probability at which E_1 is accepted at p_1 . This construction can be repeated until we obtain a refined, finite question $\{F_0, F_1, \dots, F_n, E_n\}$ such that E_n is accepted at p_n with low probability (figure 23.d)—so low that p_n is far away from corner e_n and lies on or above the line L . Therefore:

Lemma 9. *Continuing from the preceding lemma, $p_n \Vdash_{\beta} E_n$.*

Then inconsistency arises:

Lemma 10. *Continuing from the preceding lemma, let line segment $\overline{p_n f_n}$ intersect L at v . Then $v \Vdash_{\beta} \perp$.*

Proof. Proposition E_n is accepted by β at e_n , by construction; and F_0 is accepted at f_n , by the geometry of Reflexivity (proposition 8). So the disjunction $E_n \vee F_n$ is

accepted by β at both endpoints of line segment $\overline{p_n f_n}$. Then, by the geometry of Or (proposition 10), $v \Vdash_\beta E_n \vee F_n$. But $v \Vdash_\beta F_0$, because v lies on L and thus refines q . Since $\perp = F_0 \wedge (E_n \vee F_n)$, we have that $v \Vdash_\beta \perp$, as required. \square

Here is the *coup de grace*, of which theorem 7 is an immediate corollary.

Lemma 11. *Continuing from the preceding lemma, let \mathcal{P}_{n+2} be the set of probability measures defined on $\mathcal{A}_{\mathcal{E}_{n+2}}$, where \mathcal{E}_{n+2} is the question $\{F_0, \dots, F_n, E_n\}$. Then β accepts \perp at each credal state p in facet $\mathcal{P}_{n+2}|(F_0 \vee F_n \vee E_n)$.*

Proof. Let Δ denote the two-dimensional facet $\mathcal{P}_{n+2}|(F_0 \vee F_n \vee E_n)$. Suppose that v lies in the interior, but not the sides, of Δ . Since \perp is accepted at v , we have that \perp is accepted at the three corners f_0, f_n, e_n of Δ , by projecting v to the three corners and by the geometry of Cautious Monotonicity (proposition 9). Then, since each side of Δ has endpoints that are corners, we have that \perp is accepted on the three sides of Δ , by the geometry of Or (proposition 10). Then, since each point on Δ is on a line segment with endpoints on the sides of Δ , we have that \perp is accepted at each credal state on Δ , as required. When v is *not* in the interior of Δ , v lies on side $\overline{e_n f_0}$ of Δ and, thus, cannot be projected to the opposite corner f_n . But in that case we can apply the geometry of Or (proposition 10) to line segment $\overline{v f_n}$ to show that F_n is accepted at every credal state on $\overline{v f_n}$. Similarly, $F_0 \vee E_n$ is accepted at every credal state on $\overline{w e_n}$, where w is defined to be the intersection of line L and $\overline{f_0 f_n}$. So \perp is accepted at the intersection of $\overline{v f_n}$ and $\overline{w e_n}$, which is in the interior of Δ —the second case is thus reduced to the first case. \square

15 Probalogic Generalized

We close with a natural generalization of the probalogical framework. The uniform probability measure over \mathcal{E} is the center of the simplex \mathcal{P} of probability measures on the least algebra over question \mathcal{E} and served as the probalogically weakest credal state in \mathcal{P} in the presentation to this point. But, as Levi (1967, 1969) has emphasized, the answers to question \mathcal{E} typically have different *contents* (e.g., “quantum mechanics is true” has a great deal of content but “quantum mechanics is false” has very little). Therefore, a credal state that assigns less probability to a cell that has more content could sensibly be understood as weaker than a uniform state that accords the same probability to all cells. In that case, probalogic should be relative not only to question \mathcal{E} , but to an assignment of contents to the answers to \mathcal{E} . The result is a family of probalogics sensitive both to the cardinality of question \mathcal{E} and to the relative contents of the answers to \mathcal{E} .

We approach the issue as follows. If the answers E_i differ in content, it is natural to weight answers by *weakness* and to think of the neutral credal state as the center of

mass of the answers. As a result, the weakest credal state is biased toward answers of low content. In particular, the center of \mathcal{P} is stronger than a state closer to a very weak answer. Recall that probalogic is just the geological cube in perspective. The sides of the cube have equal length. To represent differences in content, deform the cube into an oblong box whose side lengths are inversely proportional to the strengths of the corresponding answers. (figure 24). Just like the cube, the oblong box may be viewed

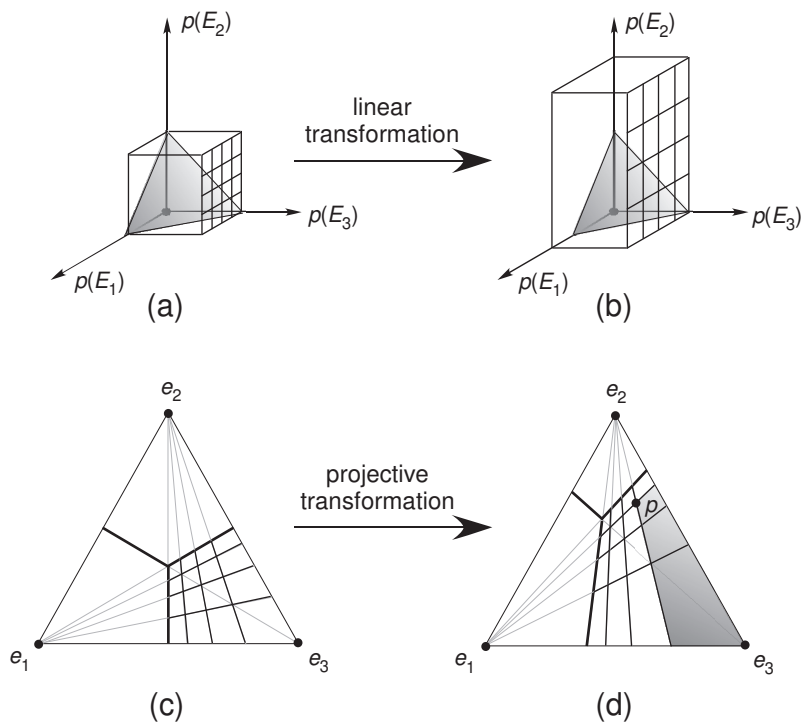

Figure 24: deformation of geologic and corresponding deformation of probalogic

as a *generalized geologic* (recall that geological structure does not uniquely determine the metric). Project the generalized geologic from the box to the triangle credal state space, just as before, to induce a *generalized probalogic* on it. Then the credal states stronger than p are those in the grey region of figure 24.d. Disjunction and conjunction are defined as before.

The weakest proposition in the generalized geologic is (m_1, m_2, m_3) (i.e. the vertex of the box that is most distant from the origin), so its rectilinear projection w to the triangle is the weakest credal state in the corresponding probalogic. Projection preserves ratios between the rectangular coordinates, so we have: $w = (\frac{m_1}{M}, \frac{m_2}{M}, \frac{m_3}{M})$, where $M = \sum_{i \in I} m_i$. The coordinates of w uniquely determine the generalized proba-

logic that has w as the weakest state. Intuitively, the result is like viewing a phone booth, rather than a cubical office, from the origin (figure 24.d).²¹ Acceptance rules are still defined as maps that preserve probalogical structure and they look like figure 25. Although the generalized probalogical acceptance rules appear “oblique”, the

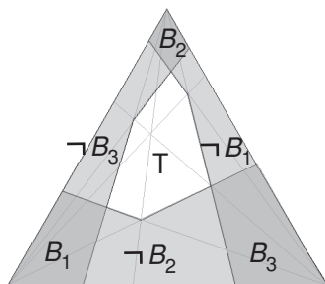

Figure 25: generalized probalogical acceptance rule

boundaries of acceptance zones still follow rays from the corners—so they still validate exactly Adams’ conditional logic. Algebraically, the generalized rules take the following form:

$$\alpha(p) = \bigwedge \left\{ \neg E_i : \frac{p(E_i)/m_i}{\max_j p(E_j)/m_j} \triangleleft_i 1 - r_i \text{ and } i \in I \right\}.$$

The acceptance rules introduced in Levi (1996: 286) are the same, except that we allow different thresholds r_i for different answers E_i while Levi does not. As we mentioned at the outset, Levi sees no justification for these rules, relative to his momentous understanding of acceptance as an explicit decision to condition one’s credal state on the accepted proposition and, therefore, to bet one’s life on it against nothing. Our own justification for the rules, grounded in a weaker conception of acceptance as apt description of one’s credal state relative to a question, is again, that they preserve naturally defined logical structures over credal states relative to a question and that they validate exactly Adams’ logic of conditionals.

16 Acknowledgements

The authors are indebted to Teddy Seidenfeld for referring us to the passage in which Levi defines the camera shutter rules and to Horacio Arlo-Costa for recommending that our semantic results be presented in terms of nonmonotonic reasoning rather than in terms of conditionals. Finally, we are indebted to Hannes Leitgeb for sharing

²¹In terms of projective geometry, the geological transformation is a non-rotational, non-reflective linear transformation and, thus, the induced probalogical transformation is a projective transformation that fixes all the corners.

his alternative approach based on conditional acceptance rules with us. We are also indebted to Clark Glymour and Greg Wheeler for useful questions.

17 Bibliography

- Adams, E.W. (1975) *The Logic of Conditionals*, Dordrecht: D. Reidel.
- Alchourron, C.E., P. Gardenfors, and D. Makinson (1985), "On the Logic of Theory Change: Partial Meet Contraction and Revision Functions", the *Journal of Symbolic Logic*, 50, 510-530.
- Arló-Costa, H. and R. Parikh (2005) "Conditional Probability and Defeasible Inference", *Journal of Philosophical Logic* 34: 97-119.
- Barwise, K. (1969) "Infinitary logic and admissible sets", *Journal of Symbolic Logic* 34: 226-252.
- Douven, I. (2002) "A New Solution to the Paradoxes of Rational Acceptability", *British Journal for the Philosophy of Science* 53: 391-410.
- Douven, I., and T. Williamson (2006) "Generalizing the Lottery Paradox", in *British Journal for the Philosophy of Science* 57: 755-79.
- Grove, A. (1988), "Two Modellings for Theory Change", *Journal of Philosophical Logic*, 17(2): 157-170.
- Hajek, P. (1998), *Metamathematics of Fuzzy Logic*, Dordrecht: Kluwer.
- Harper, W. (1975) "Rational Belief Change, Popper Functions and Counterfactuals", *Synthese*, 30(1-2): 221-262.
- Karp, C. (1964) *Languages with Expressions of Infinite Length*, Dordrecht: North Holland.
- Kelly, K. (1998) "Iterated Belief Revision, Reliability, and Inductive Amnesia," *Erkenntnis*, 50: 11-58.
- Kelly, K. (2008) "Ockham's Razor, Truth, and Information", in *Handbook of the Philosophy of Information*, ed. J. van Benthem and P. Adriaans, Dordrecht: Elsevier.
- Kelly, K. (2010) "Ockham's Razor, Truth, and Probability", forthcoming in *Handbook on the Philosophy of Statistics*, Prasanta Bandyopadhyay and Malcolm Forster, eds., 2010 Dordrecht: Elsevier.

- Kraus, S., Lehmann, D. and Magidor, M. (1990) “Nonmonotonic Reasoning, Preferential Models and Cumulative Logics”, *Artificial Intelligence* 44, 167-207.
- Kyburg, H. (1961) *Probability and the Logic of Rational Belief*, Middletown: Wesleyan University Press.
- Lehmann, D. and Magidor, M. (1992) “What does a Conditional Base Entails?”, *Artificial Intelligence* 55, 1-60.
- Levi, I. (1967) *Gambling With Truth: An Essay on Induction and the Aims of Science*, New York: Harper & Row. 2nd ed. Cambridge, Mass.: The MIT Press, 1973.
- Levi, I. (1969) “Information and Inference”, *Synthese* 19: 369-91.
- Levi, I. (1996) *For the Sake of the Argument: Ramsey Test Conditionals, Inductive Inference and Non-monotonic Reasoning*, Cambridge: Cambridge University Press.
- Lin, H. (2010) “A New Theory of Acceptance that Solves the Lottery Paradox and Provides a Simplified Probabilistic Semantics for Adams’ Logic of Conditionals”, Master’s thesis, Carnegie Mellon University, Pittsburgh, PA.
- Makinson, D. and P. Gardenfors (1991) “Relations Between the Logic of Theory Change and Nonmonotonic Logic”, in A. Fuhrmann and M. Morreau (eds.), *The Logic of Theory Change*, Springer-Verlag Lecture Notes in Computer Science 465, 183-205.
- Novak, V., Perfilieva, I., and Mockor, J. (2000) *Mathematical principles of fuzzy logic*, Dordrecht: Kluwer.
- Pearl, J. (1989) “Probabilistic Semantics for Nonmonotonic Reasoning: A Survey”, In Proc. First International Conference on Principles of Knowledge Representation and Reasoning (KR ’89): 505-516. Reprinted in G. Shafer and J. Pearl (Eds.), *Readings in Uncertain Reasoning*, San Francisco: Morgan Kaufmann, 699-710.
- Pollock, J. (1995) *Cognitive Carpentry*, Cambridge, MA: MIT Press.
- Ramsey, F.P. (1929) “General Propositions and Causality”, in F. Ramsey, *Philosophical Papers*, ed. H. A. Mellor, Cambridge: Cambridge University Press, 1990.
- Ryan, S. (1996) “The Epistemic Virtues of Consistency”, *Synthese* 109: 121-41.
- Savage, L. J. (1972) *The Foundations of Statistics*, New York: Dover.
- van Fraassen, B. (1995) “Fine-grained Opinion, Probability and the Logic of Full Belief”, *Journal of Philosophical Logic*, 24, 349-377.

Zadeh, L. (1965) "Fuzzy Sets", *Information and Control* 8: 338-353.